

# OPERATOR'S MANUAL

## SUPPLEMENT

Model No. 114D-XX  
115D-XX

### ⚠ WARNING:

Read Engine Owner's Manual, Vehicle Operator's Manual, and Supplement Carefully Before Operating Vehicle.

Parts List



### ORDERING PARTS

FAST & EASY!

- 1) Seek Part(s) from your models illustrated diagram, cross over REF# to PART#
- 2) Type PART# into sites [Search Box] at [GoKartsRus.com](http://GoKartsRus.com) TIP! - RIGHT CLICK LINK, SELECT OPEN IN NEW TAB
- 3) Add all needed parts to Shopping Cart | Complete "Checkout" | ✓ Done!

If a part does not come up in a Site Search, please [Contact Us](#) (include part# in email)

LOWEST PRICES!

## THIS VEHICLE IS FOR OFF-ROAD USE ONLY

BEFORE OPERATING THIS VEHICLE, THE OWNER AND/OR OPERATOR MUST UNDERSTAND THE VEHICLE WAS NOT DESIGNED OR MANUFACTURED TO MEET SPECIFICATIONS FOR USE ON STREETS, HIGHWAYS, OR THOROUGHFARES AND HAVE READ AND HAVE AN UNDERSTANDING OF ALL THE INSTRUCTIONS FOR SAFE ASSEMBLY AND OPERATION AS WELL AS THE INSTRUCTIONS GOVERNING THE ENGINE AND OTHER PORTIONS OF THE VEHICLE.

# PARTS LIST MODELS 114 & 115

REF	PART #	DESCRIPTION
1	12950-37	FRAME - RED WAGON
	12950-41	FRAME - JD GREEN
	12950-45	FRAME - PURPLE WAVE
2	12606	FRONT WHEEL ASSY 4IN - YELLOW
NI	1053	REPLACEMENT TUBE FOR #2 & #32
NI	2244	REPLACEMENT TIRE FOR #2 & #32
3	13552	SPROCKET - 36 X 12T
4	13504	BOLT 1/2-13 X 1.00 HHCS G5 ZINC
5	5090	BEARING 5/8ID X 1-3/8OD SNAP RING
6	6568	SPANNER 5/8ID X 3-7/8 LONG
7	1036	BRAKE BAND
8	9116	COTTER PIN
9	12933	AXLE
10	13522	IMPELLER
11	1447	SHLD BOLT 5/16-18 X 11/16THD
12	9503	PEDAL SPRING - RIGHT WOUND
13	6293-16	BRAKE PEDAL
14	6309-16	THROTTLE PEDAL
NI	9929	VINYL CAP .25 BLACK (PEDAL STOPS)
15	12087	SPROCKET W/DRUM 36T 5/8ID
16	6038	STEERING WHEEL
17	1264	BOLT 1/2-13 X 3.75 HHCS G2 ZINC
18	13503	NUT 1/2-13 CENTERLOCK HEX ZINC
19	1136	NUT 5/8-18 CENTERLOCK HEX JAM ZINC
20	13354	NUT 5/8-11 CENTERLOCK HEX ZINC
21	6572	CHAIN 35 X 54 PITCH (INCL #88)
22	9788	CHAIN 35 X 58 PITCH (INCL #88)
23	5839	BOLT 1/4-20 X .750 HH WHIZ FLNGE ZINC
24	9085	NUT 3/8-16 TOPLOCK HEX ZINC
25	9118	CLEVIS PIN
26	1876	BOLT 1/4-20 X .625 HH WHIZ FLNGE ZINC
27	1119	SPACER .625ID X 1.062OD .125THICK
28	8252	THROTTLE CABLE 61IN (INCL #90)
30	12032-2Z	RIGHT SPINDLE BLACK WITH ZERK
31	12033-2Z	LEFT SPINDLE BLACK WITH ZERK
32	12607	REAR WHEEL ASSY 4IN - YELLOW
33	12593-2	BRAKE ROD - BLACK
34	8850	LAP BELT

REF	PART #	DESCRIPTION
35	9188	BOLT 1/2-13 X 1.50 HHCS G5 ZINC
36	1848	BOLT 1/4-20 X 1.25 HHCS G5 ZINC
37	9057	NUT 1/4-20 TOPLOCK ZINC
38	1854	WASHER NBR 14 FLAT ZINC
39	1399	BUSHING .25ID X .031G X .313
40	9146	BOLT 3/8-16 X 1.50 HHCS G5 ZINC
41	9145	BOLT 3/8-16 X 1.75 HHCS G5 ZINC
42	1263	NUT 5/16-18 HEX WHIZ FLANGE ZINC
43	11808	VINYL CAP 1.5ID X 1.5L - BLACK
44	9022	WASHER 1/2 STD FLAT ZINC
45	11361	FLAG MOUNTING BOLT
46	4266-16	SPACER .875OD X .625ID X 1.125L ZINC
47	10869	TIE ROD ASSY 19IN. (INCL 54 - 57, & 93)
48	1031	KEY 3/16 SQ X .50 LONG
49	3403	KEY 3/16 SQ X 2.00 LONG
50	12600	TOP GUARD
51	12599	BOTTOM GUARD
52	9502	PEDAL SPRING - LEFT WOUND
53	12981	TIE ROD ASSY 8.75IN. (INCL. 54-57 & 59)
54	1414	TIE ROD END - RIGHT THREAD
55	9092	NUT 3/8-24 RIGHT HEX JAM ZINC
56	9024	NUT 3/8-24 LEFT JAM ZINC
57	1415	TIE ROD END - LEFT THREAD
58	9674-16	SPACER 3/8ID X 3/8L ZINC
59	12980	TIE ROD 8.75 INCH
60	2386	BOLT 3/8-16 X 3.50 HHCS G5 ZINC
61	9080	BOLT 1/4-20 X 2.75 HHCS G2 ZINC
62	9160	BOLT 1/4-20 X .875 HHCS NYLOCK G5 Z
63	1093	BEARING 5/8ID 1-3/8OD
64	12766	STOP WIRE ASSEMBLY
65	12246	ENGINE
66	12971	CLUTCH
67	9060	WASHER 5/16 TYPE A SAE ZINC
68	9101	BOLT 5/16-24 X .50 HHCS NYLOCK G5 Z
69	9186	BOLT 5/16-18 X 1.50 HHCS G5 ZINC
70	9030	WASHER 5/16 IL ZINC
71	1398	WASHER 21/64 ID X 1-1/4 X 1/8

REF	PART #	DESCRIPTION
72	8139	BOLT 5/16-24 X 1.00 HHCS G5 ZINC
73	12347	SWIVEL SCREW
74	12348	RETURN SPRING
75	13452-2	ENGINE BACKING PLATE - BLACK
76	8227	NUT 1/4-20 CLIP
77	12967	SEAT BACK / BOTTOM
78	12957-2	FRONT BAR - BLACK
	12957-39	FRONT BAR - YELLOW
79	13053-2	REAR BAR - BLACK
	13053-39	REAR BAR - YELLOW
80	12970-2	SEAT FRAME - BLACK
81	12979	SPANNER 11.563 LONG
82	12742-2	JACKSHAFT WDMT - BLACK
83	2386	BOLT 3/8-16 X 3.50 HHCS G5 ZINC
84	5447	SAFETY FLAG - 6 FT
88	1269	MASTER LINK 35
89	1189	NUT 5/16-18 HEX TOP LOCK ZINC
90	9058	NUT 5/16-24 HEX JAM ZINC
91	1124	WASHER 5/16 SL ZINC
92	9091	WASHER 3/8 FLAT SAE ZINC
93	10868	TIE ROD 19 INCH
94	6452	BOLT 3/8-16 X 5.00 HHCS G5 ZINC
95	13056-2	CENTER BAR - BLACK
	13056-39	CENTER BAR - YELLOW
96	13550	JACKSHAFT

**NI = NOT ILLUSTRATED**

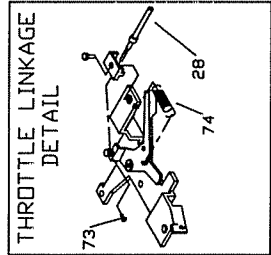
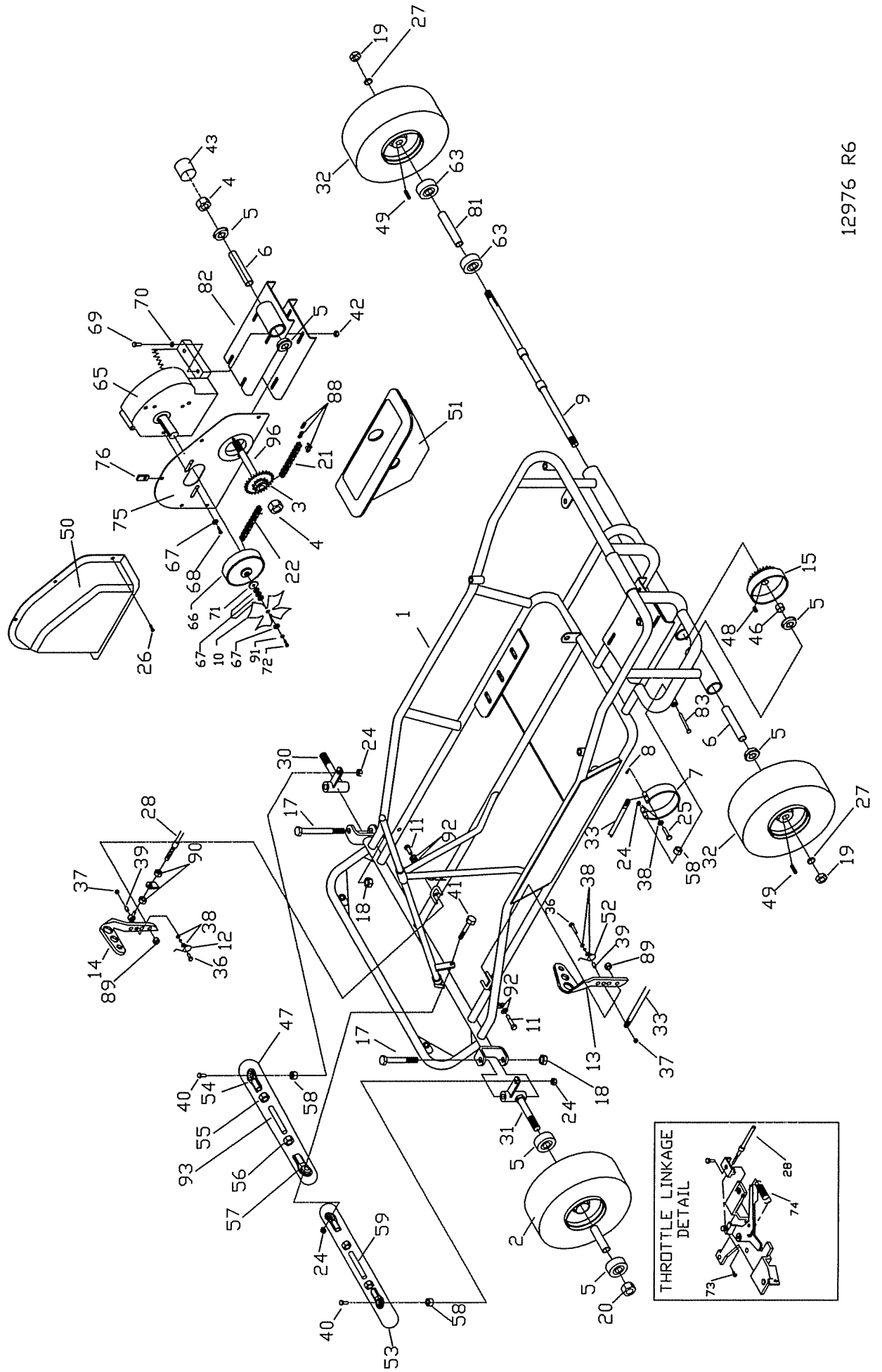

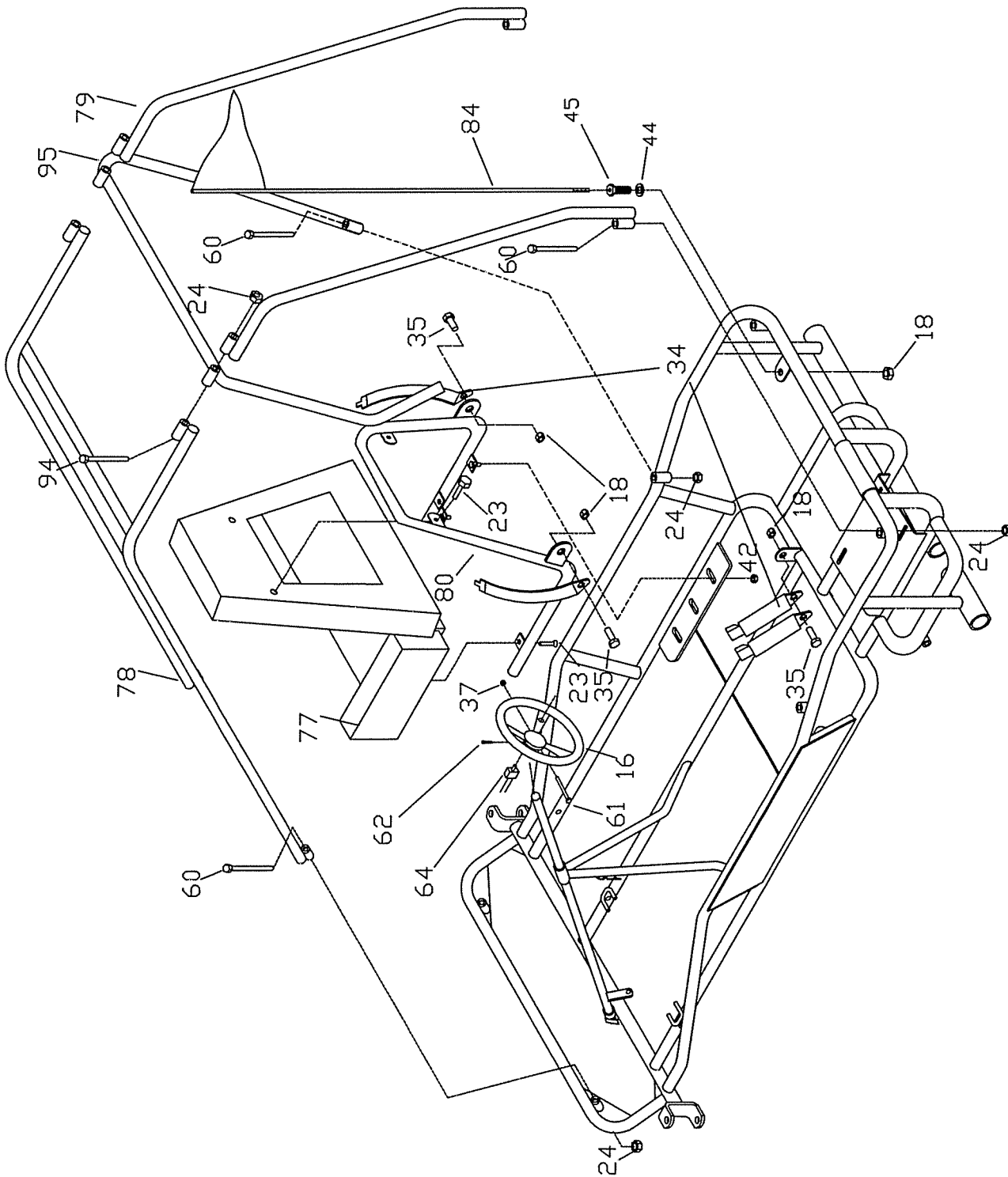

12976 R6

## ORDERING PARTS

**FAST & EASY!**

- 1) Seek Part(s) from your models illustrated diagram, cross over REF# to PART#
- 2) Type PART# into sites [Search Box] at [GoKartsRus.com](http://GoKartsRus.com) TIP! - RIGHT CLICK LINK, SELECT OPEN IN NEW TAB
- 3) Add all needed parts to Shopping Cart | Complete "Checkout" | ✓ Done!

If a part does not come up in a Site Search, please [Contact Us](#) (include part# in email)

**LOWEST PRICES!**

