

*File Copy*

# Operator's Manual SUPPLEMENT

MANCO MODEL NO.

285-207

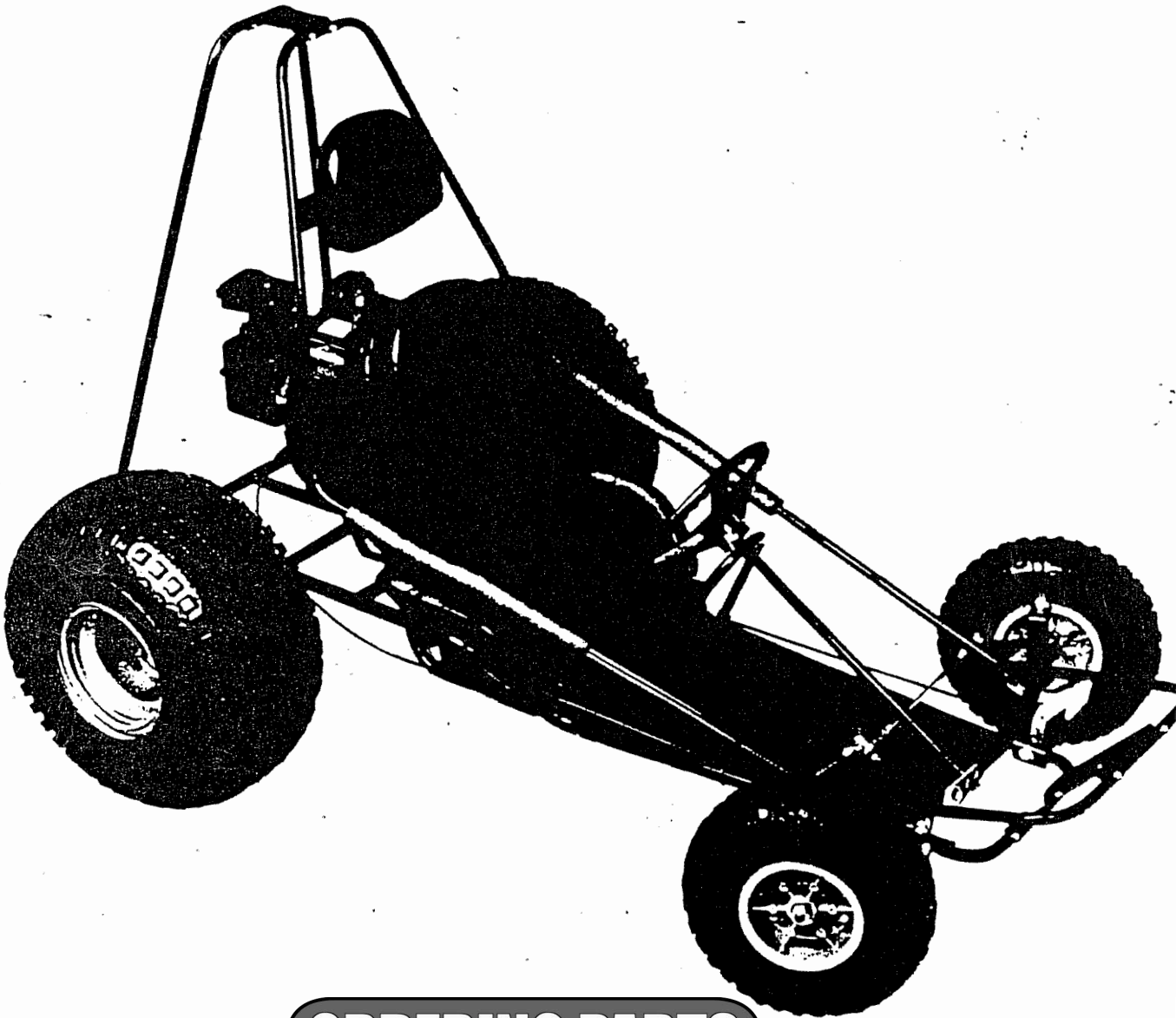

## ORDERING PARTS

- 1) Seek Part(s) from your models illustrated diagram, cross over REF# to PART#
- 2) Type PART# into sites [Search Box] at [GoKartsRus.com](http://GoKartsRus.com) TIP! - RIGHT CLICK LINK, SELECT OPEN IN NEW TAB
- 3) Add all needed parts to Shopping Cart | Complete "Checkout" | ✓ Done!

If a part does not come up in a Site Search, please [Contact Us](#) (include part# in email)

**FAST & EASY!**

**LOWEST PRICE!**

SEE BACK PAGE OF SUPPLEMENT FOR THROTTLE ATTACHMENT ILLUSTRATION

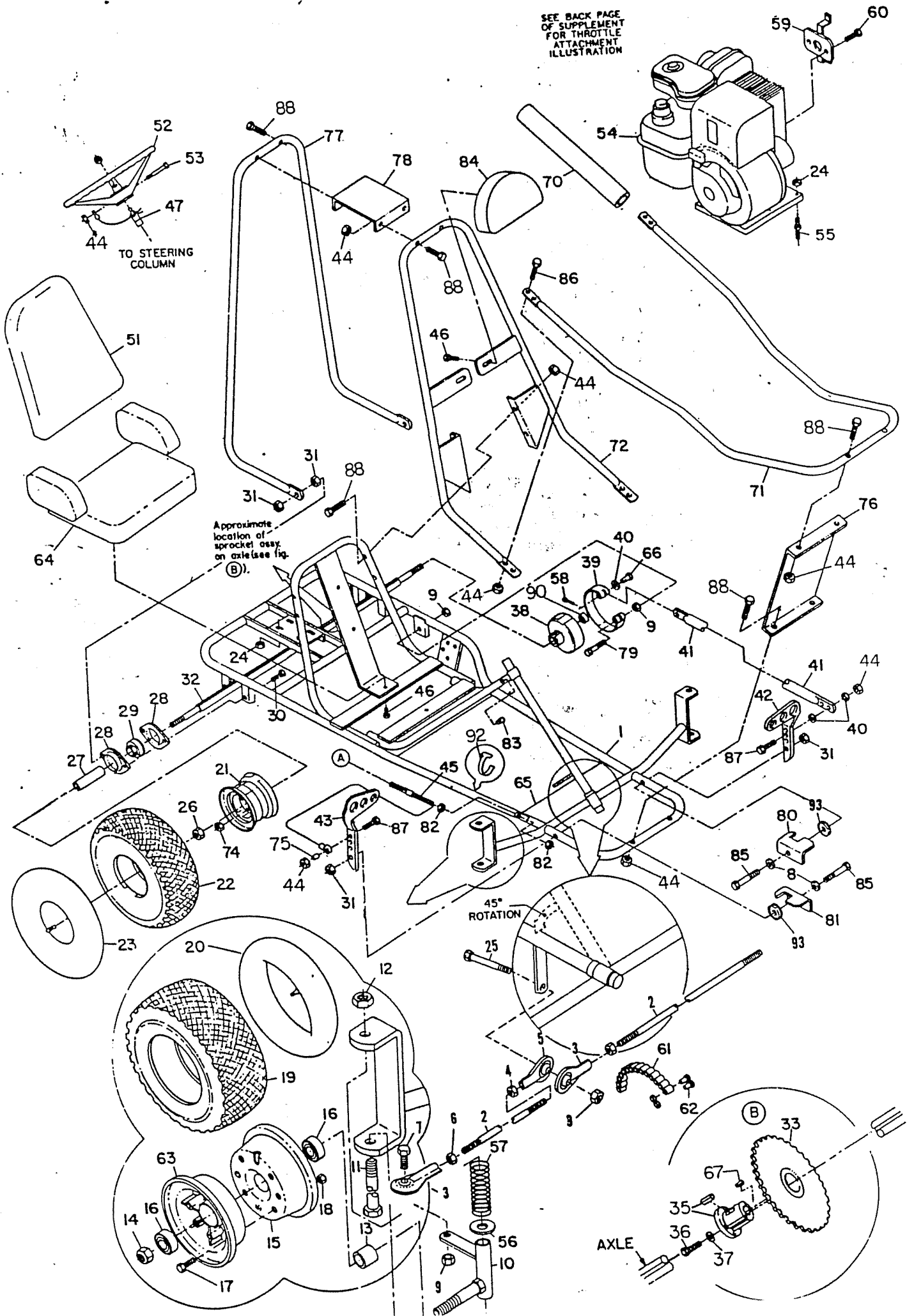

# REPAIR PARTS

## MODEL 285-207

REF. NO.	PART NO.	DESCRIPTION	REF. NO.	PART NO.	DESCRIPTION
	1514	Frame	58	9116	3/32 x 3/4 Cotter pin
ASM	1464	Tie rod asm, inc. ref. no's. 2-5	59	4269-2	Cover mounting bracket
2	1465	Tie rod	60	9101	5/16-24 x 1/2 Hex nylock screw
3	1415	Rod end - left hand	61	1524	#420 Chain - 60 pitch
4	9092	3/8-24 Hex jam nut - right hand thread	62	2037	#420 Masterlink
5	1414	Rod end - right hand	63	1539	Wheel half - 6" aluminum - gold
6	9024	3/8-24 Hex jam nut - left hand thread	64	5160	Seat bottom
7	9146	3/8-16 x 1 1/2 Hex cap screw	65	1441	Scuff pad
8	9091	3/8 Flat washer	66	9118	1/4 x 1-1/4 Clevis pin
9	9085	3/8-16 Hex UTA locknut	67	6123	Key - 1/4 square x 1-3/4
10	1467	Spindle - right hand	68	1320	Spring Anchor
NI	1468	Spindle - left hand	69	1321	Screw-spring anchor
11	5682	1/2-13 x 5-1/2 Hex cap screw	70	6126	Pad
12	1012	1/2-13 Hex UTA locknut	71	3089-2	Front bar
13	5157	Spacer - front axle	72	3092-2	Center bar
14	1046	5/8-11 Hex UTA locknut	73		Not used
ASM	3803	Wheel asm. - 6" - inc. ref. no's. 15-20, 63.	74		Not used
15	1092	Wheel half - 6" - aluminum	75	1389	Bushing - 1/4 x 5/16
16	1093	Bearing	76	1607	Front plate
17	1185	1/20 x 3/4 Hex whizlock screw Gr 5	77	1608-2	Rear bar
18	1186	1/4-20 Hex whizlock nut	78	1602	Rear plate
19	3801	15 x 6.00-6 Knobby tire	79	1449	3/8-16 x 2 Hex head screw Gr 5
20	3802	5.30-4.50 x 6 Tube	80	1609	Bracket - brake pedal
ASM	3554	Wheel asm. - 18" - inc. ref. no's. 21-22	81	1615	Bracket - throttle pedal
21	3552	Wheel hub - 8" - steel	82	9058	5/16-24 Jam nut
22	3548	18x9.50-8 Tubeless Tire	83	1463	Plastic bushing
23	1430	18-9.50 x 8 Tube (Repair part only)	84	5717	Pad - headrest
24	1263	5/16-18 Hex flanged whizlock nut	85	1447	Shoulder bolt
25	9158	3/8-16 x 2 1/2 Hex cap screw	86	1845	1/4-20 x 5/8 Hex cap screw Gr 5
26	9052	3/4-16 Hex UTA locknut	87	1846	1/4-20 x 3/4 Hex cap screw Gr 5
27	1448	Spacer - 1" I.D. x 3-9/16	88	1848	1/4-20 x 1-1/4 Hex cap screw Gr 5
28	1760	Flange - bearing	89	1628	Cable retainer
29	3941	Bearing - axle	90	1082	Spacer - 1 x 7/16
30	2532	5/16-18 x 1 Hex cap screw	91		Not used
31	1189	5/16-18 UTA locknut	92	1019	Ty-wrap
32	1561	Axle - 38-1/2"	NI	2581	Owners manual
33	2528	Sprocket - 54 tooth - #41	NI	1406	Stop switch lead wire asm.
35	2531	Bushing w/key	NI	1624	Decal set
36	9122	5/16-18 x 1-1/4 HHCS Gr 5	NI	1394	Lead wire asm.
37	1124	5/16 Lockwasher	ASM	2944	Hub & sprocket asm. inc. ref. no's. 33, 35, 36, 37, & 67.
38	1078	Brake drum			
39	1492	Brake band			
40	1854	1/4 Flat washer			
41	8040	Brake rod			
42	1436	Brake pedal			
43	1437	Throttle pedal			
44	9057	1/4-20 Hex locknut			
45	1390	Throttle cable asm.			
46	9006	1/4-20 x 1/2 Flanged hex head whizlock screw			
47	1391	Stop switch assembly			
48	3160	Spring-throttle return			
49	1285	Connector			
50	1018	Cable stop w/screw			
51	5159	Seat back			
52	1626	Steering wheel			
53	9080	1/4-20 x 2-3/4 Hex cap screw			
54	6010	5 HP Engine			
55	1356	Mounting stud assembly			
56	9022	Flat washer			
57	5681	Spring			

NI = Not illustrated

ASM = Assembly

# REPAIR PARTS TORQUE CONVERTER DRIVE

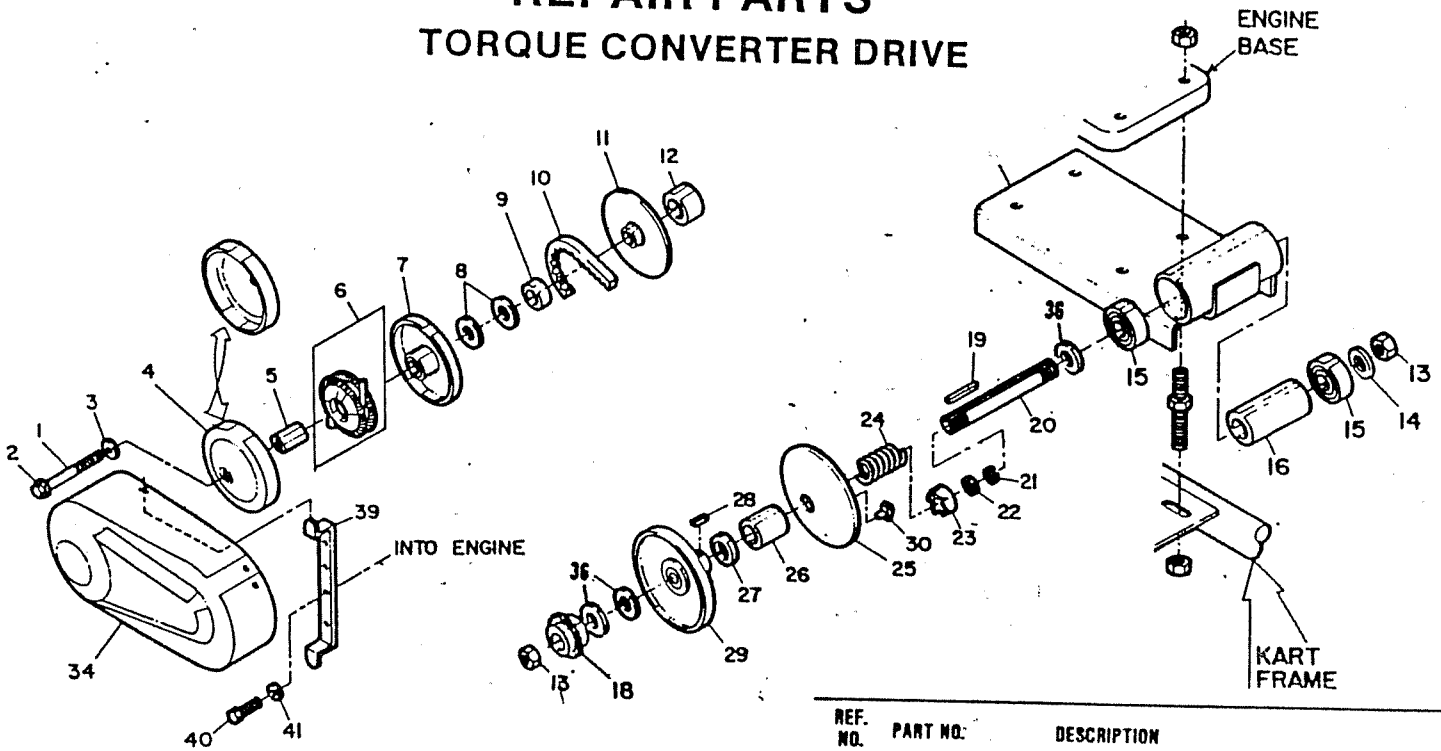

REF. NO.	PART NO.	DESCRIPTION
1	1454	Bolt 5/16-24 x 1-1/2
2	1124	Lockwasher, 5/16 ID Helical Spring
3	1398	Washer, 21/64 ID
ASM	2792	Driving Pulley, Includes #4-9 & 11
4		Driver Drum
5		Driver Hub
6		Driver Shoe Assembly
7		Moveable Sheave — Driver
8		Washer
9		Bushing Bronze
10	4292	Belt
11		Stationary Sheave — Driver
12	1442	Spacer-3/4 ID x 1/4 long
13	1136	5/8-18 Lock Nut
14	1469	Washer 1/16 x 5/8 ID x 1 00
15	5090	Bearing
16	1116	Bearing Spanner
17	—	Not Used
18	1125	Sprocket #420 x 9 Tooth
19	3403	Key 3/16 x 3/16 x 2
20	1118	Jackshaft
ASM	2778	Driven Pulley, Includes 21-29 & 30
21		Cup Washer
22		Retaining Ring
23		Fixed Cam
24		Torsion Spring
25		Moveable Face & Cam
26		Bushing
29		Fixed Face & Post
30	2516	Button, Insert
31	1110-2D	Chassis Weldment
34	3809T	Drive Cover-Trimmed
36	1937	Spacer, 3/4 ID x 1/4 long
39	4269-2	Cover Mounting Clip
40	9101	5/16-24 x 1/2 Nylok Hex Head Screw
41	9030	5/16 ID Internal Tooth Lockwasher

## THROTTLE CABLE INSTALLATION

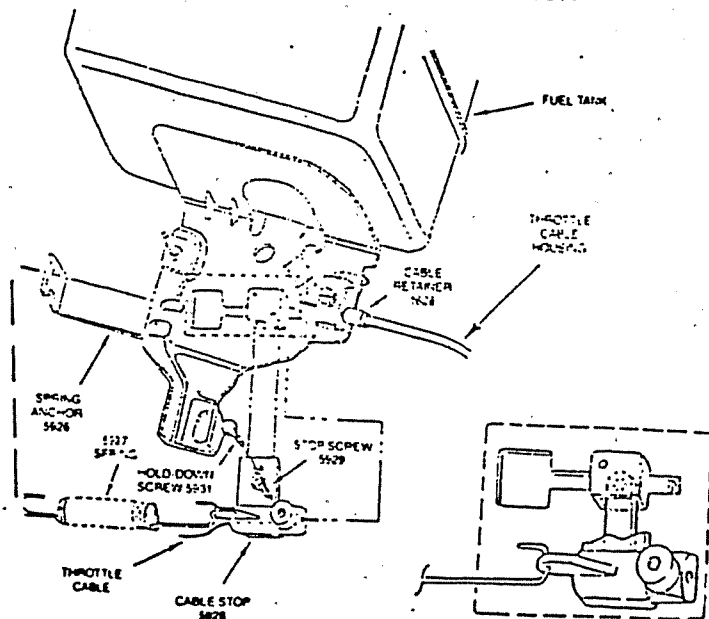

**ASSEMBLY:** Pass the throttle cable through the cable retainer and butt the throttle cable housing end against the inside shoulder of the cable retainer. (The cable retainer is to be securely fastened to the engine with the clamping screw.) Pass the end of the Throttle Cable through the hole in the cable stop. Before tightening cable stop screw:

1. Ensure spring anchor, spring, and cable are installed as illustrated above.
2. Ensure throttle pedal is in rearward (idle) position.
3. Ensure that there is no slack in the throttle cable with no tension applied to return spring.
4. Ensure cable housing is inside and against the cable retainer.