

*File Copy*

# Operator's Manual SUPPLEMENT

MANCO MODEL NO.,  
285-01

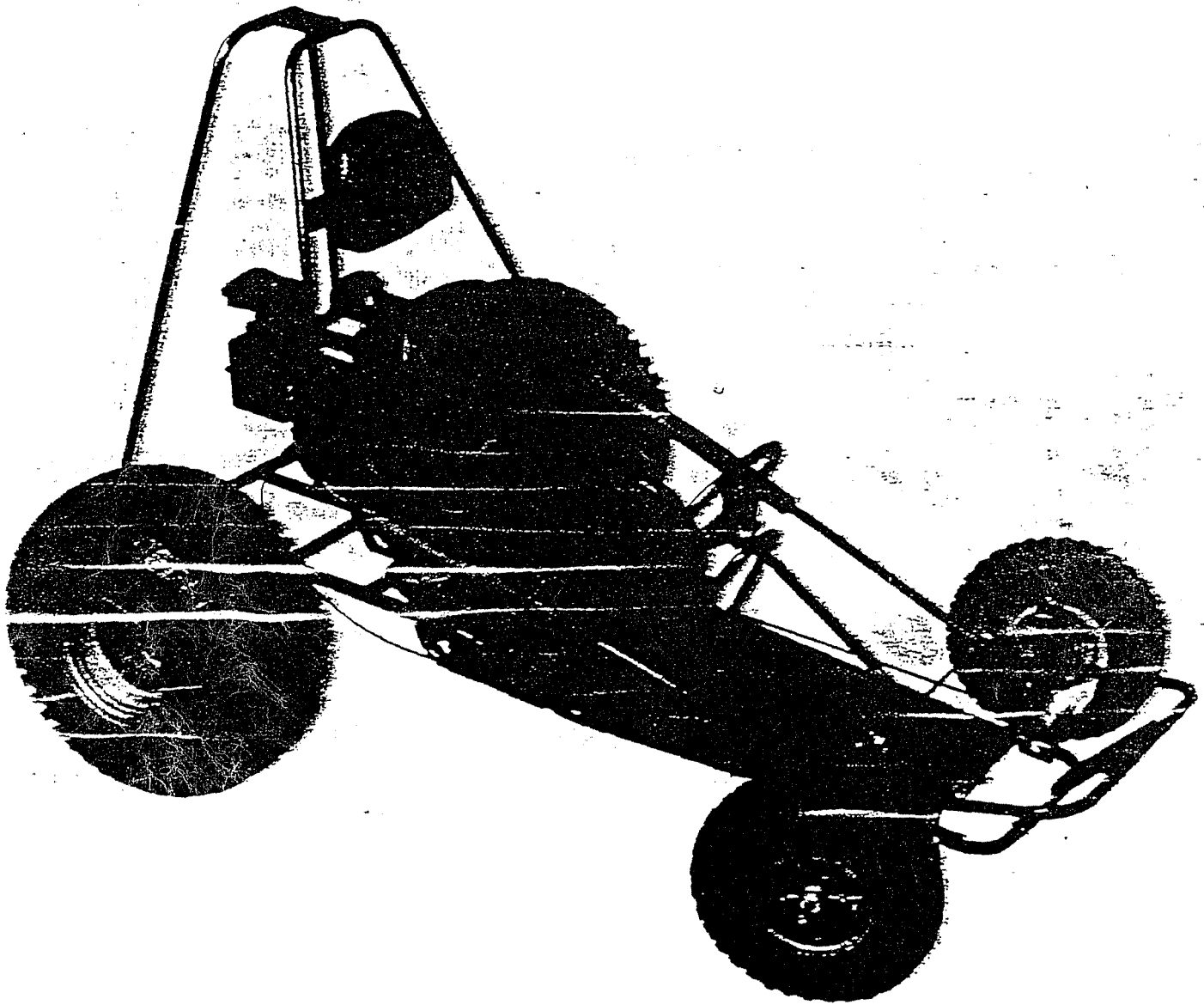

## ORDERING PARTS

- 1) Seek Part(s) from your models illustrated diagram, cross over REF# to PART#
- 2) Type PART# into sites [Search Box] at [GoKartsRus.com](http://GoKartsRus.com) TIP! - RIGHT CLICK LINK, SELECT OPEN IN NEW TAB 
- 3) Add all needed parts to Shopping Cart | Complete "Checkout" |  Done!

If a part does not come up in a Site Search, please [Contact Us](#) (include part# in email)

**FAST & EASY!**

**LOWEST PRICES!**

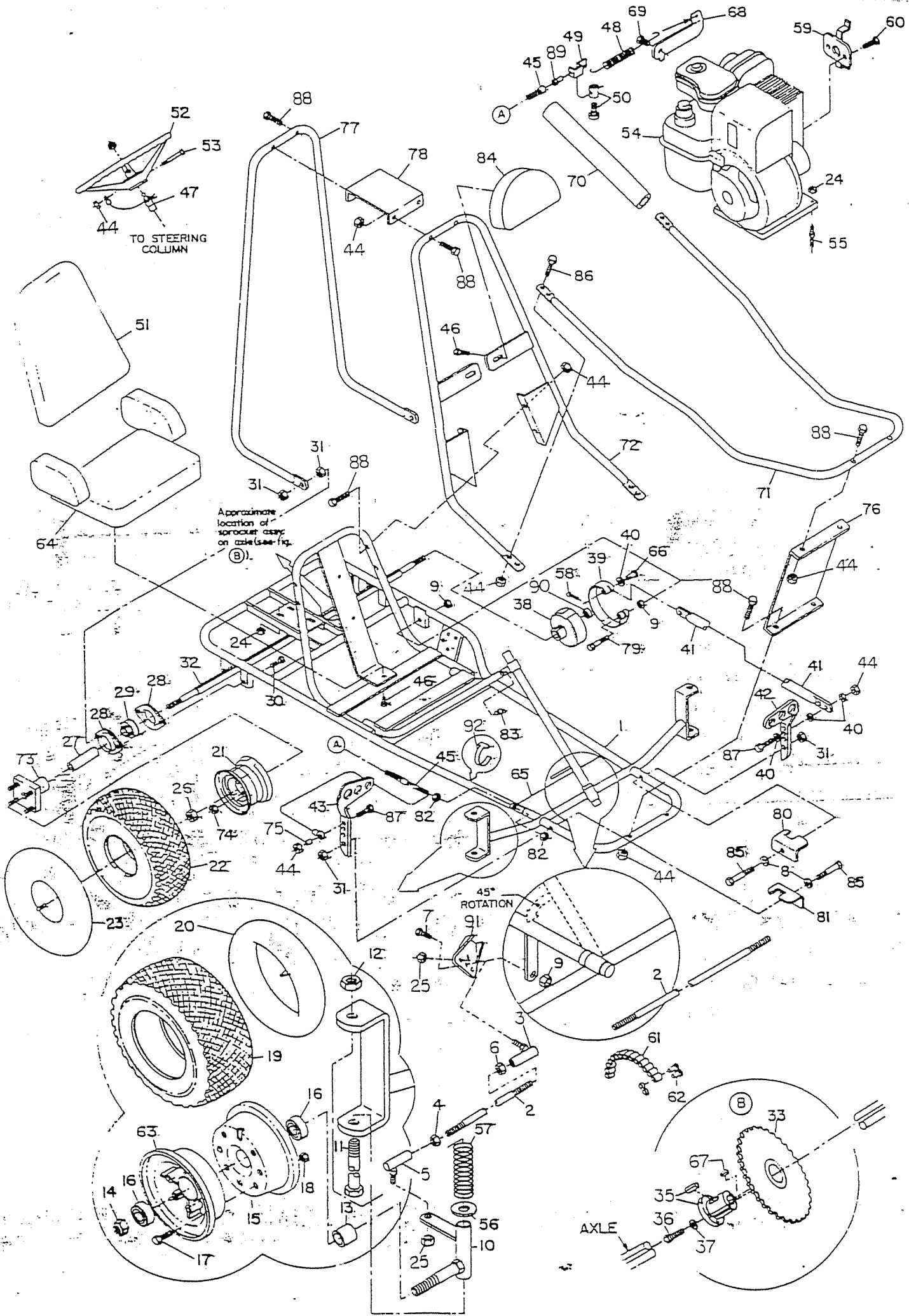

# REPAIR PARTS

## MODEL 285-01

REF. NO.	PART NO.	DESCRIPTION	REF. NO.	PART NO.	DESCRIPTION
	1514	Frame	58	9116	3/32 x 3/4 Cotter pin
ASM	4449	Tie rod asm. inc. ref. no's.	59	1494	Cover mounting bracket
2	4448	Tie rod	60	9101	5/16-24 x 1/2 Hex nylock screw
3	3338	Rod end - left hand	61	1524	#420 Chain - 60 pitch
4	9092	3/8-24 Hex jam nut - right hand thread	62	2037	#420 Masterlink
5	3337	Rod end - right hand	63	1539	Wheel half - 6" aluminum - gold
6	9024	3/8-24 Hex jam nut - left hand thread	64	5160	Seat bottom
7	4070	3/8-16 x 3/4 Hex cap screw	65	1441	Scuff pad
8	9091	3/8 Flat washer	66	9118	1/4 x 1 1/4 Clevis pin
9	9085	3/8-16 Hex UTA locknut	67	6123	Key - 1/4 square x 1 3/4
10	1467	Spindle - right hand	68	1320	Spring anchor
NI	1468	Spindle - left hand	69	1321	Screw
11	5682	1/2-13 x 5 1/2 Hex cap screw	70	6126	Pad
12	1012	1/2-13 Hex UTA locknut	71	3094-2	Front bar
13	5157	Spacer - front axle	72	3093-2	Center bar
14	1046	5/8-11 Hex UTA locknut	73	1557	Wheel flange
ASM	3803	Wheel asm. - 6" - inc. ref. no's. 15-20, 63.	74	1428	Lug nut
15	1092	Wheel half - 6" - aluminum	75	1389	Bushing - 1/4 x 5/16
16	1093	Bearing	76	1607	Front plate
17	1185	1/4-20 x 3/4 Hex whizlock screw Gr 5	77	1608	Rear bar
18	1186	1/4-20 Hex whizlock nut	78	1602	Rear plate
19	3801	15 x 6.00-6 Knobby tire	79	1449	3/8-16 x 2 Hex head screw Gr 5
20	3802	5.30-4.50 x 6 Tube	80	1609	Bracket - brake pedal
ASM	1412	Wheel asm. - 21" - inc. ref. no's. 21-22	81	1615	Bracket - throttle pedal
21	1451	Wheel hub - 8" - steel	82	9058	5/16-24 Jam nut
22	1452	21 x 12-8 Tubeless ATV tire	83	1463	Plastic bushing
23	1430	18-9.50 x 8 Tube (Repair part only)	84	5717	Pad - headrest
24	1263	5/16-18 Hex flanged whizlock nut	85	1447	Shoulder bolt
25	9123	3/8-24 Hex toplock nut	86	1845	1/4-20 x 5/8 Hex cap screw Gr 5
26	9052	3/4-16 Hex UTA locknut	87	1846	1/4-20 x 3/4 Hex cap screw Gr 5
27	1671	Spacer - 1 1/4" D x 4 3/16	88	1848	1/4-20 x 1 1/4 Hex cap screw Gr 5
28	1760	Flange - bearing	89	1628	Cable retainer
29	1759	Bearing - axle	90	1082	Spacer - 1 x 7/16
30	2532	5/16-18 x 1 Hex cap screw	91	4334-2	Steering plate
31	1189	5/16-18 UTA locknut	92	1019	Ty-wrap
32	1561	Axle - 38 1/2	NI	2581	Owners manual
33	2528	Sprocket - 54 tooth - #41	NI	1406	Stop switch lead wire asm.
35	2531	Bushing w/key	NI	1624	Decal set
36	9122	5/16-18 x 1 1/4 HHCS Gr 5	NI	1394	Lead wire asm.
37	1124	5/16 Lockwasher	ASM	2944	Hub & sprocket asm. inc. ref. no's. 33, 35, 36, 37, & 67
38	1078	Brake drum			
39	1492	Brake band			
40	1854	1/4 Flat Washer			
41	8040	Brake rod			
42	1436	Brake pedal			
43	1437	Throttle pedal			
44	9057	1/4-20 Hex locknut			
45	1390	Throttle cable asm.			
46	9006	1/4-20 x 1/2 Flanged hex head whizlock screw			
47	1391	Stop switch assembly			
48	3160	Spring - throttle return			
49	1285	Connector			
50	1018	Cable stop w/screw			
51	5159	Seat back			
52	1626	Steering wheel			
53	9080	1/4-20 x 2 3/4 Hex cap screw			
54	6010	5 HP Engine			
55	1356	Mounting stud assembly			
56	9022	Flat washer			
57	5681	Spring			

NI = Not illustrated  
ASM = Assembly

# REPAIR PARTS TORQUE CONVERTER DRIVE

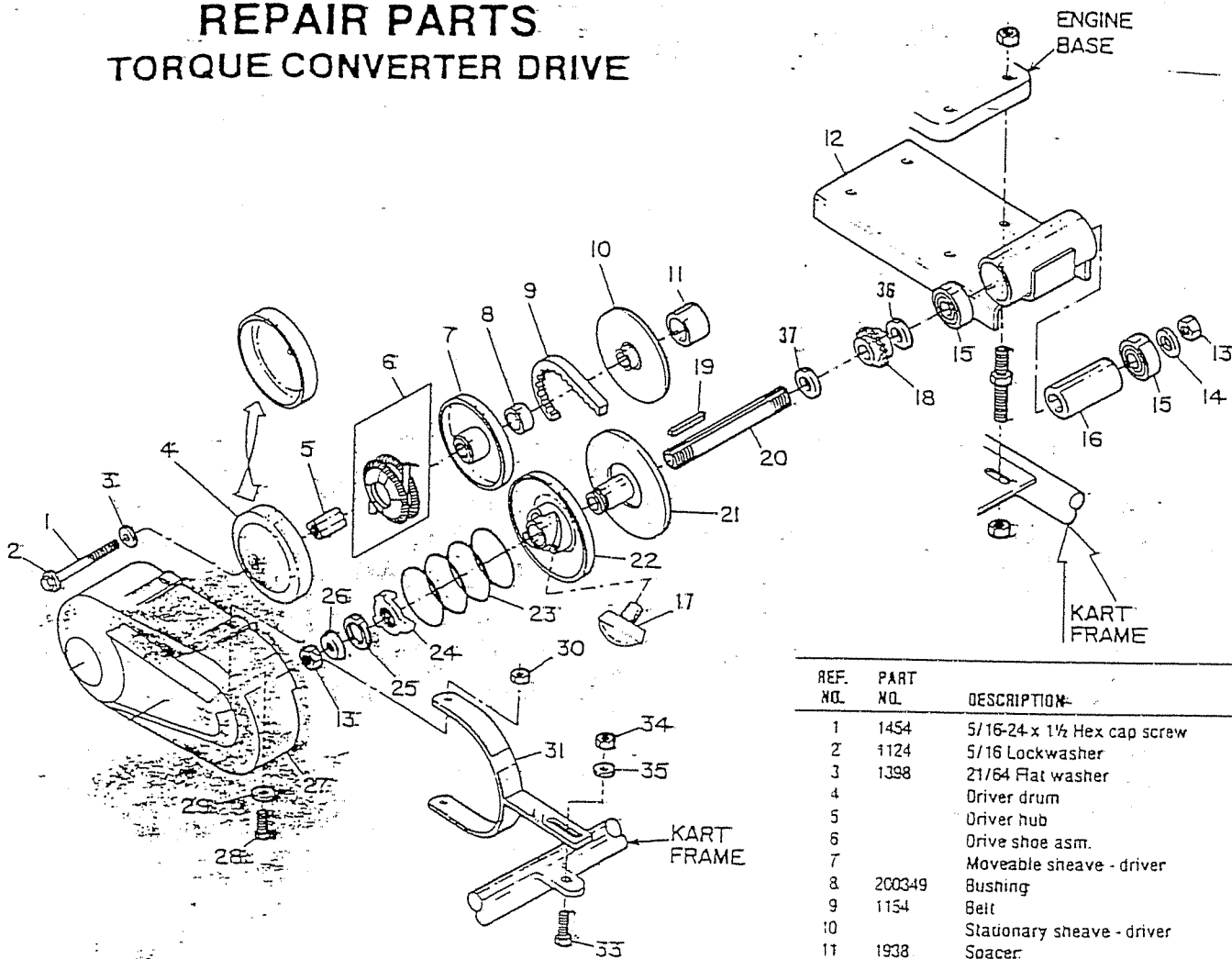

REF. NO.	PART NO.	DESCRIPTION-
1	1454	5/16-24 x 1 1/2 Hex cap screw
2	1124	5/16 Lockwasher
3	1398	2 1/4 Flat washer
4		Driver drum
5		Driver hub
6		Drive shoe asm.
7		Moveable sheave - driver
8	200349	Bushing
9	1154	Belt
10		Stationary sheave - driver
11	1938	Spacer
12	1110	Chassis
13	1136	5/8-18 UTA Locknut
14	1469	5/8 I.D. Spacer/washer
15	5090	Bearing
16	1116	Bearing spanner
17	2516	Nylon button - cam - heavy duty
18	1125	Sprocket - 9 tooth - 1/2" pitch
19	3403	3/16 square x 2
20	1118	Jackshaft
21		Stationary sheave
22		Moveable sheave with cam
23	204114	Spring
24		Cam
25	2477	Retaining ring
26	204489	Cup washer
27	1542	Cover
28	2277	#8-32 x 1/2 Hex head screw
29	2279	#8 Flat washer
30	2278	#8-32 UTA Locknut
31	1537	Mounting bracket
33	1846	1/2-20 x 3/4 Hex head screw Gr 5
34	9057	1/2-20 UTA Locknut
35	1854	1/4 Flat washer
36	1937	5/8 I.D. x 7/8 O.D. x 1/4 Spacer
37	1119	5/8 I.D. x 7/8 O.D. x 1/8 Spacer
ASM	1148	Driving pulley asm. (assembled to crankshaft)
ASM	1127	Driven pulley asm. (assembled to jackshaft)

## THROTTLE CABLE INSTALLATION.

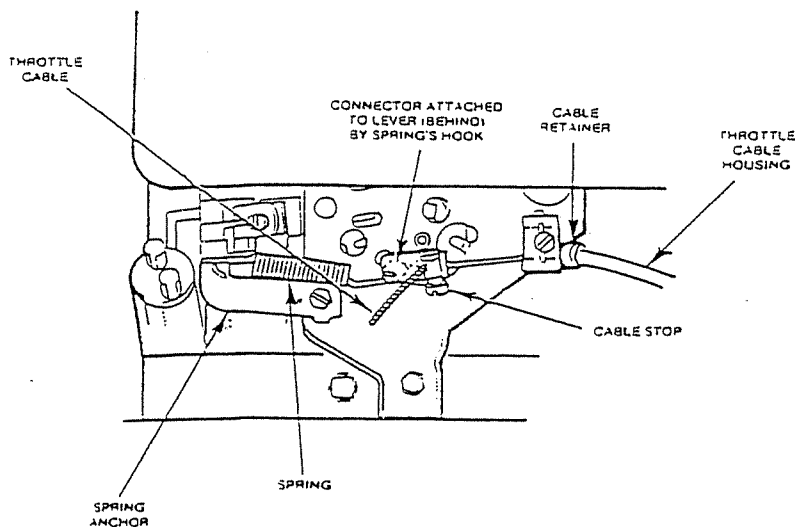

**ASSEMBLY:** Pass the throttle cable through the cable retainer and butt the throttle cable housing end against the inside shoulder of the cable retainer. (The cable retainer is to be securely fastened to the engine with the clamping screw.) Pass the end of the Throttle Cable through the hole in the bent end of the connector and through the cable stop. The cable stop should fit into the bend of the connector. Before tightening cable stop screw:

- Ensure spring anchor, spring, and connector are installed as illustrated above.
- Ensure throttle pedal is in rearward (idle).
- Ensure cable stop is against connector and no slack is in throttle cable with no tension applied to spring.