

Operator's Manual SUPPLEMENT

MANCO MODEL NO.
388-17

WARNING:
Read Engine
Owner's Manual,
Vehicle Operator's
Manual, and
Supplement
Carefully Before
Operating
Vehicle.

Parts List



MANCO
PRODUCTS, INC.

ORDERING PARTS

FAST & EASY!

- 1) Seek Part(s) from your models illustrated diagram, cross over REF# to PART#
- 2) Type PART# into sites [Search Box] at GoKartsRus.com TIP! - RIGHT CLICK LINK, SELECT OPEN IN NEW TAB
- 3) Add all needed parts to Shopping Cart | Complete "Checkout" | ✓ Done!

If a part does not come up in a Site Search, please [Contact Us](#) (include part# in email)

LOWEST PRICES!

BEFORE OPERATING THIS VEHICLE, THE OWNER AND/OR OPERATOR MUST UNDERSTAND THE VEHICLE WAS NOT DESIGNED OR MANUFACTURED TO MEET SPECIFICATIONS FOR USE ON PUBLIC ROADS, STREETS, HIGHWAYS, OR THOROUGHFARES AND HAVE READ AND HAVE AN UNDERSTANDING OF ALL THE INSTRUCTIONS FOR SAFE ASSEMBLY AND OPERATION AS WELL AS THE INSTRUCTIONS GOVERNING THE ENGINE AND OTHER PORTIONS OF THE VEHICLE.

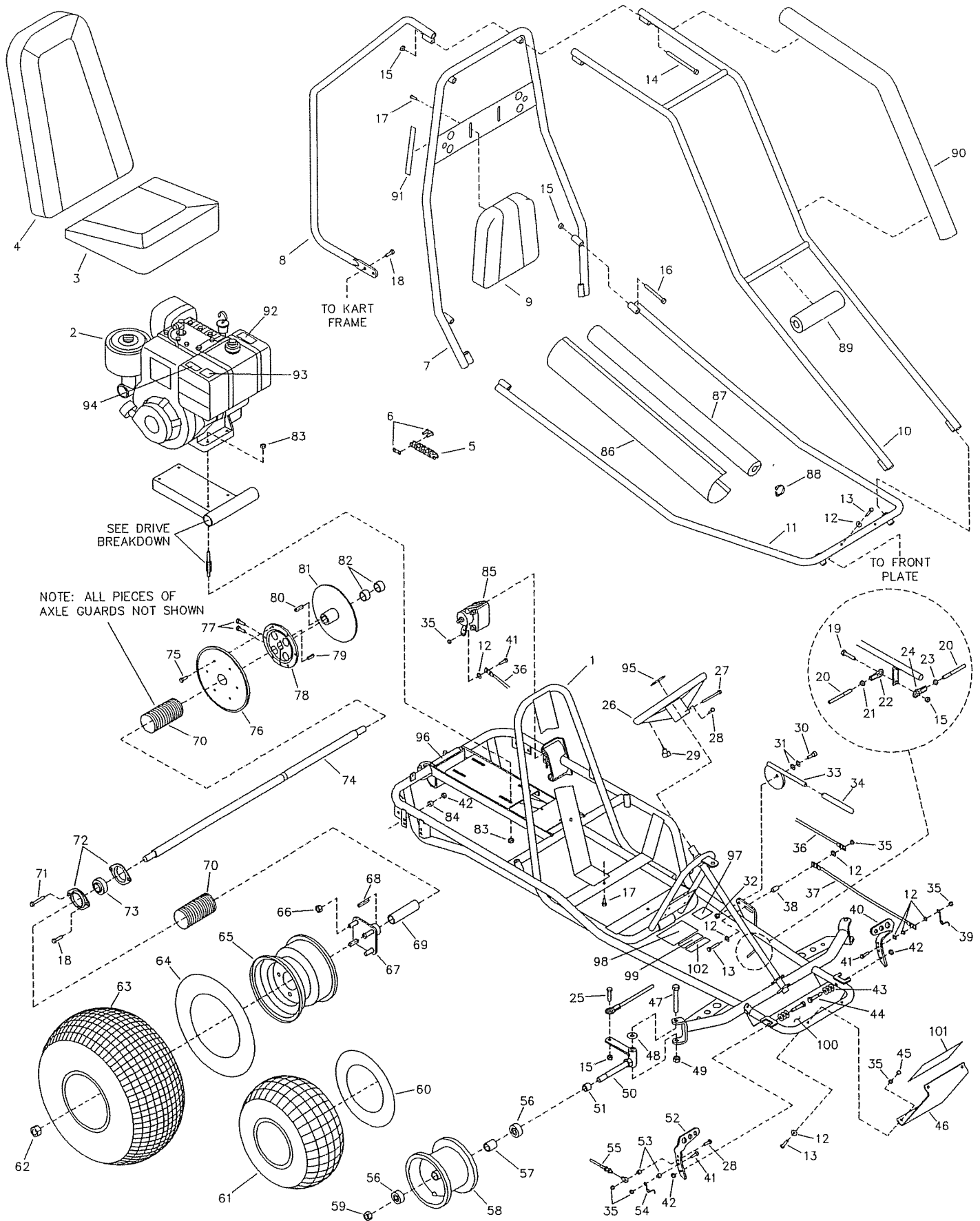

REPAIR PARTS - 388-17

REF. NO.	PART NO.	DESCRIPTION	REF. NO.	PART NO.	DESCRIPTION
1	8195-2	Frame	60	3802	Inner Tube, 6"
2	8196	Engine, 8hp Tecumseh	61	4915	Tire, 145/70 x 6 Knobby
3	5160	Seat Bottom	62	9162	Nut, 3/4-10 Toplock
4	5159	Seat Back	ASM	1412	Wheel Asm, Rear (incl. 63-65)
5	9343	Chain, 420 x 71 Links (incl. 6)	63	1452	Tire, 22 x 11 - 8 Tubeless
6	2037	Master Link, 420 Chain	64	1430	Inner Tube, 8" (Repair Part Only)
7	9522-2	Center Bar	65	1451	Wheel Rim, 8"
8	9527-2	Rear Bar	66	1428	Nut, 1/2-13 Cone Wheel
9	6320	Headrest	67	1557	Wheel Hub w/Studs
10	9525-2	Overhead Bar	68	6123	Key, 1/4 sq. x 1-3/4"
11	9524-2	Front Bar	69	4660	Spacer, 1" ID x 4-7/16"
12	1854	Washer, No. 14 Flat	70	K389-12	Axle Guard Repair Kit
13	1849	Bolt, 1/4-20 x 1-1/2"	71	6573	Bolt, 5/16-18 x 1-3/4"
14	6452	Bolt, 3/8-16 x 5"	72	6617	Bearing Flange
15	9085	Nut, 3/8-16 Toplock	73	3941	Bearing, 1" ID
16	2386	Bolt, 3/8-16 x 3-1/2"	74	8223	Axle Shaft
17	5839	Bolt, 1/4-20 x 3/4" Flanged Whiz	ASM	6420	Sprocket Asm. (incl. 75-78)
18	9176	Bolt, 5/16-18 x 1"	75	9006	Bolt, 1/4-20 x 1/2" Flanged Whiz
19	9145	Bolt, 3/8-16 x 1-3/4"	76	6282	Sprocket, 420 x 54 Teeth
ASM	6430	Tie Rod Asm. (incl. 20-24)	77	6701	Bolt, 5/16 x 1-1/4" Socket Head
20	6431	Tie Rod	78	6280	Sprocket Hub
21	9092	Nut, 3/8-24 RH Jam	79	9680	Key, 1/4 x 3/8 x 1-1/4"
22	1414	Rod End - RH	80	1775	Key, 1/4 sq. x 1-1/4"
23	9024	Nut, 3/8-24 LH Jam	81	6314	Brake Rotor
24	1415	Rod End - LH	82	2265	Spacer, 1" ID x 3/4"
25	9146	Bolt, 3/8-16 x 1-1/2"	83	1263	Nut, 5/16-18 Flanged Whiz
26	6038	Steering Wheel	84	9674	Spacer, 3/8 ID x 3/8"
27	9080	Bolt, 1/4-20 x 2-3/4"	85	8197	Brake Caliper Asm.
28	9160	Bolt, 1/4-20 x 7/8" Nylock	86	9856	Custom Cover
29	9799	Stop Switch Assembly	87	9759B	Foam, 30" Black
NI	1406	Wiring Harness	88	9777	Plastic Hose Clamp, 7/8" ID
30	9172	Bolt, 3/8 x 1/4 Shoulder	89	9808B	Foam, 10" Black
31	6441	Washer, 3/8 ID Spring	90	9758B	Foam, 43" Black
32	6440	Nut, 5/16-18 Jam	91	6540	Decal, Warning: Wear Helmet
33	6773-2	Parking Brake Handle	92	9677	Decal, Warning: Hot Surfaces
34	6442	Brake Handle Cover	93	9678	Decal, Warning: Engine Exhaust
35	9057	Nut, 1/4-20 Toplock	94	5964	Decal, Oil Warning
36	8215-2	Rear Brake Rod	95	1689	Decal, Steering Wheel
37	9638-2	Front Brake Rod	96	2873	Decal, Trailer Load
38	9869	Spacer, 1/4 ID x 5/16 OD x 5/8"	97	8138	Decal, Warning: Entanglement
39	9502	Spring, Left Wound	98	4504	Decal, Yellow Warning
40	1436	Pedal, Brake	99	2832	Decal, No Passengers
41	1847	Bolt, 1/4-20 x 1"	100	1441	Decal, Front Floor Pan
42	1189	Nut, 5/16-18	101	1688	Decal, Front Plate
43	9091	Washer, 3/8 Flat	102	8153	Decal, Age Restriction
44	1447	Pedal Bolt	NI	9247R4	Assembly Instructions
45	1443	Nut, 1/4-20 Acorn	NI	6477	Dingo Operator's Manual
46	6395-2	Front Plate	NI	8220	Tecumseh 8hp Engine Manual
47	1264	Bolt, 1/2-13 x 3-1/2"			
48	9022	Washer, 1/2 Flat			
49	1012	Nut, 1/2-13 Toplock			
50	2457	Spindle, Right			
NI	2458	Spindle, Left			
51	5157	Spacer, 5/8 ID x 3/4"			
52	1437	Pedal, Throttle			
53	1389	Bushing, 1/4 ID x 5/16"			
54	9503	Spring, Right Wound			
55	9345	Throttle Cable			
56	5090	Bearing, 5/8 ID			
57	5950	Spanner, 5/8 ID x 2-1/8"			
58	9309FP	Wheel Assembly, Front			
59	1046	Nut, 5/8-11 Toplock			

ASM = Assembly
NI = Not Illustrated

CALIPER BREAKDOWN

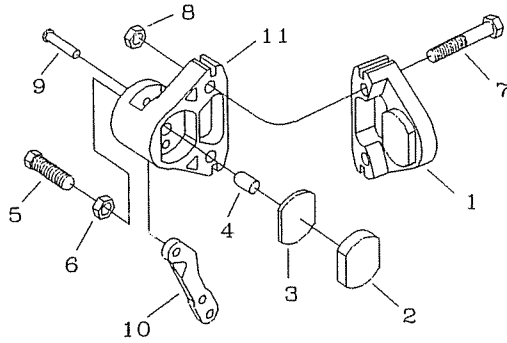

REF. NO	PART NO	DESCRIPTION
ASM	8197	Brake Caliper (incl. 1-11)
ASM	9810	Brake Pad Svc Kit (incl. 1-3)
1	*	Anvil w/Lining
2	*	Brake Lining
3	3928	Backing Plate
4	3930	Actuator Pin
5	3931	Adjuster Pin
6	3932	Nut, Jam
7	9158	Bolt, 3/8-16 x 2-1/4"
8	9085	Nut, 3/8-16 Toplock
ASM	6534	MB-1 Service Kit (incl. 9-11)
9	*	Groove Pin
10	*	Lever
11	*	Brake Housing

TORQUE CONVERTER BREAKDOWN

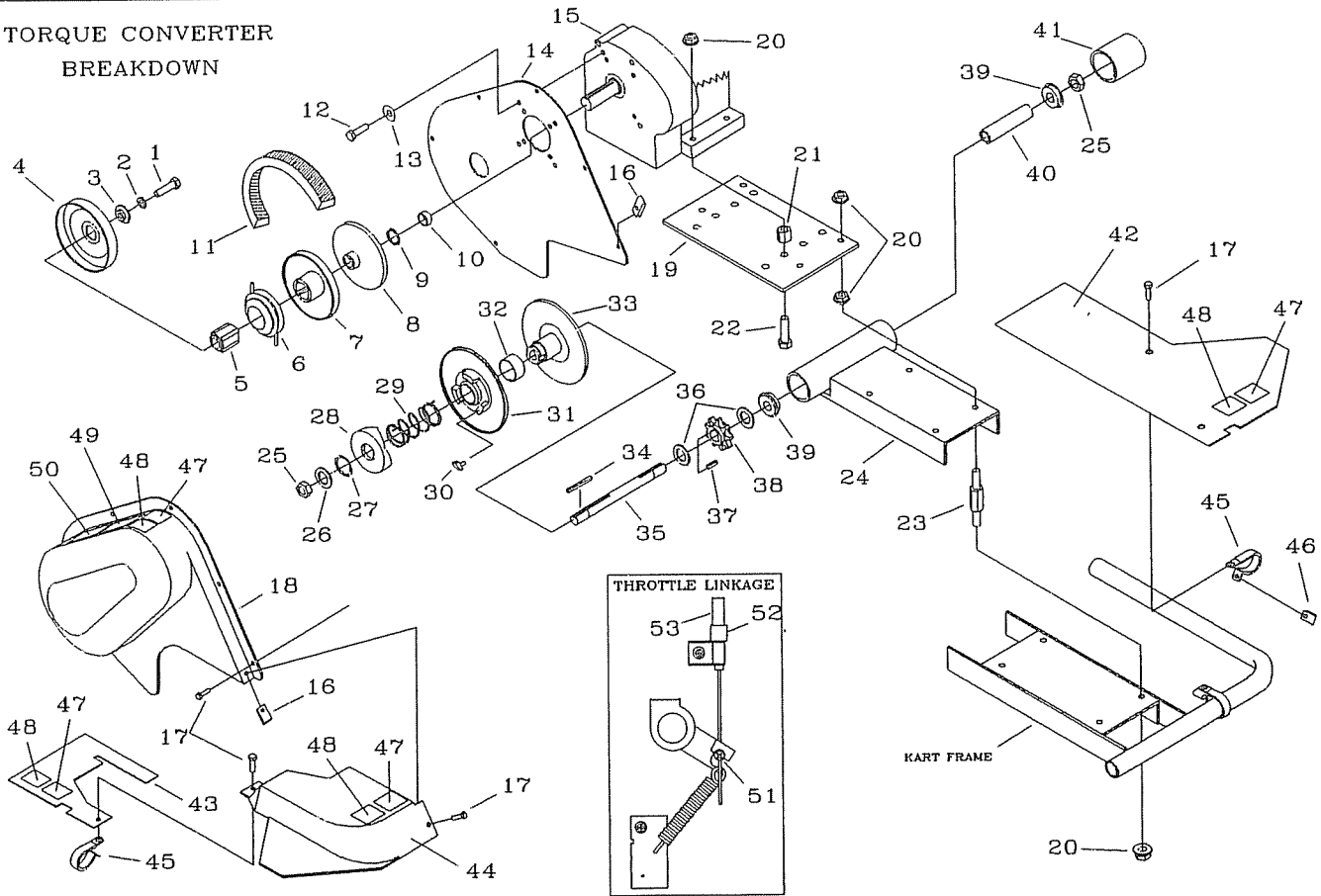

REF. NO	PART NO	DESCRIPTION
1	8203	Bolt, 3/8-24 x 1-3/4"
2	1130	Washer, 3/8 Split Lock
3	2468	Washer, Pilot
ASM	8190	Driver Pulley Assembly (incl. REF. 4-8)
4	*	Drum
5	*	Hub
6	*	Shoe Assembly
7	*	Moveable Sheave
8	*	Stationary Sheave
9	3887	Spacer, 1" ID x 1/16
10	4914	Spacer, 1" ID x 9/16
11	8192	Belt, Asymmetrical
12	9101	Bolt, 5/16-24 x 1/2"
13	9060	Washer, 5/16 Plain
14	8200	Cover Panel
15	8196	Engine, 8hp Tecumseh
16	2449	Nut, Tinnerman
17	9006	Bolt, 1/4-20 x 1/2" Whiz Flange
18	8199	Cover
19	8214-2	Adapter Plate
20	1263	Nut, 5/16-18 Flange

REF. NO	PART NO	DESCRIPTION
21	8206	Nut, 1/2-20 High
22	9127	Bolt, 5/16-18 X 2-1/4"
23	8205	Stud
24	8209-2	Chassis
25	9155	Nut, 5/8-11 Jam
26	8193	Washer, Cup
ASM	8191	Driven Pulley Assembly (incl. REF. 27-33)
27	2477	Retaining Ring
28	*	Cam
29	6805	Spring
30	6804	Button, Nylon
31	*	Moveable Sheave
32	*	Bushing
33	*	Stationary Sheave
34	3403	Key, 3/16sq x 2"
35	8219	Jackshaft
36	1119	Spacer, 5/8ID x 1/8"
37	1031	Key, 3/16sq x 1/2"
38	1125S	Sprocket, 9T #420
39	5090	Bearing
40	2430	Spanner

REF. NO	PART NO	DESCRIPTION
41	8194	Cap, Plastic
42	8265	Right Deck Cover
43	8260	Left Deck Cover
44	8259	Calliper Cover
45	8266	Loop Clip
46	8227	Clip Nut
47	1049	Decal, Caution
48	4912	Decal, Warning: Guard...
49	8138	Decal, Warning: Entanglement
50	6958	Decal, Tire Pressure
NI	9677	Decal, Warning: Hot Surfaces
NI	9678	Decal, Warning: Eng. Exhaust
NI	5964	Decal, Oil Warning
Throttle Linkage Illustration		
51	1018	Cable Stop and Swivel Screw
52	1628	Cable Retainer
53	9345	Throttle Cable

* = Not Available Separately
 ASM = Assembly
 NI = Not Illustrated