

# Operator's Manual SUPPLEMENT

MANCO MODEL NO.

405-16

405-19

**WARNING:**  
Read Engine  
Owner's Manual,  
Vehicle Operator's  
Manual, and  
Supplement  
Carefully Before  
Operating  
Vehicle.

Parts List



## ORDERING PARTS

**FAST & EASY!**

- 1) Seek Part(s) from your models illustrated diagram, cross over REF# to PART#
- 2) Type PART# into sites [Search Box] at [GoKartsRus.com](http://GoKartsRus.com) TIP! - RIGHT CLICK LINK, SELECT OPEN IN NEW TAB
- 3) Add all needed parts to Shopping Cart | Complete "Checkout" | ✓ Done!

*If a part does not come up in a Site Search, please [Contact Us](#) (include part# in email)*

**LOWEST PRICES!**

BEFORE OPERATING THIS VEHICLE, THE OWNER AND/OR OPERATOR MUST UNDERSTAND THE VEHICLE WAS NOT DESIGNED OR MANUFACTURED TO MEET SPECIFICATIONS FOR USE ON PUBLIC ROADS, STREETS, HIGHWAYS, OR THOROUGHFARES AND HAVE READ AND HAVE AN UNDERSTANDING OF ALL THE INSTRUCTIONS FOR SAFE ASSEMBLY AND OPERATION AS WELL AS THE INSTRUCTIONS GOVERNING THE ENGINE AND OTHER PORTIONS OF THE VEHICLE.

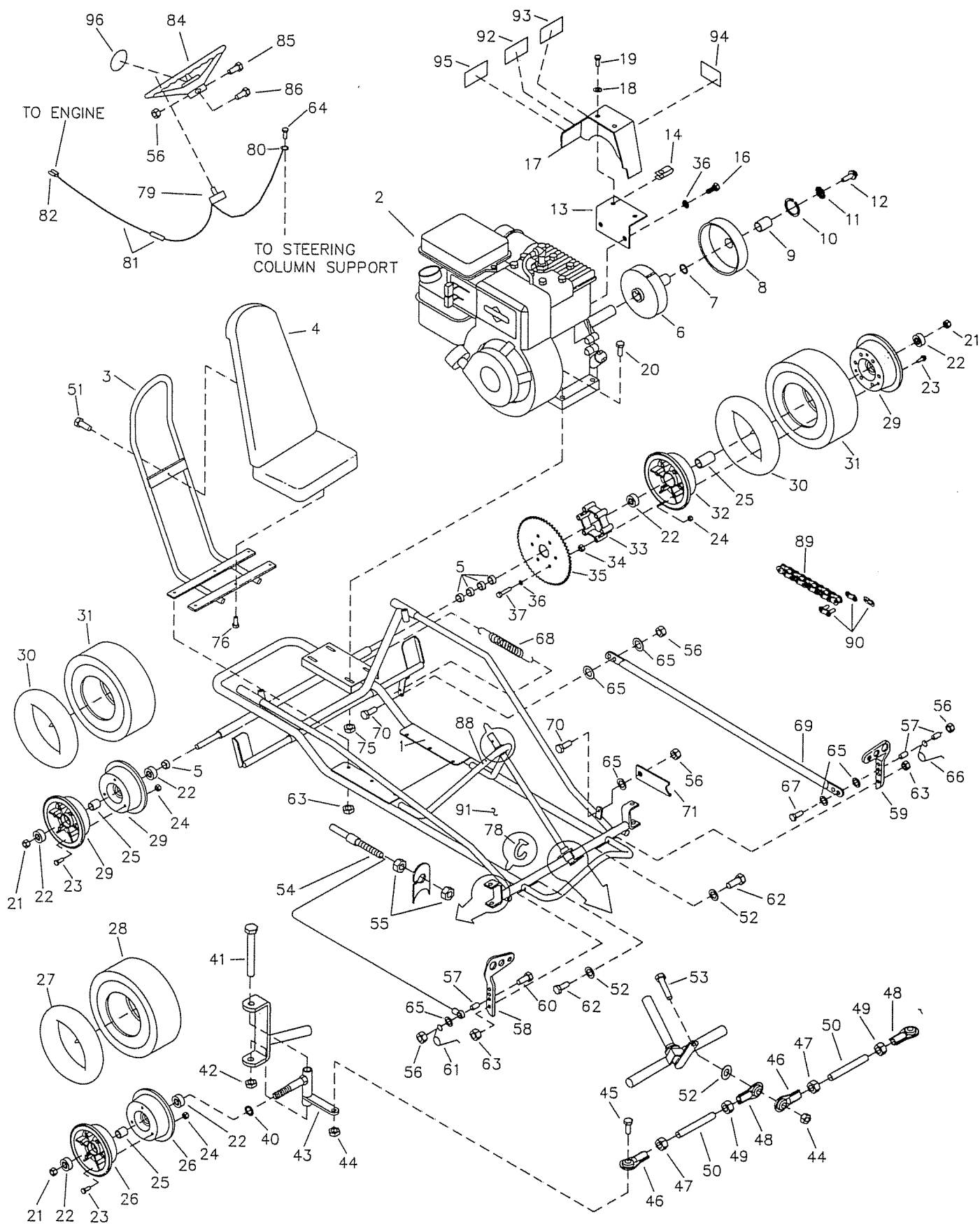

REPAIR PARTS - MODEL 405-16/-19

REF NO.	PART NO.	DESCRIPTION	REF NO.	PART NO.	DESCRIPTION
1	9574-18	Frame	53	9145	Bolt, 3/8-16 x 1-3/4"
2	6010	Engine, 5hp	54	1390	Throttle Cable w/ Housing (inc. REF 55)
3	3347-2	Seat Frame	55	9058	Nut, 5/16-24 Jam
4	4324	Seat Pad	56	9057	Nut, 1/4-20 Toplock
5	1119	Spacer, 5/8 ID x 1/8"	57	1389	Bushing
ASM	4335	Clutch Assembly (inc. REF 6-10)	58	1437	Pedal, Throttle
6	4496	Clutch Rotor	59	1436	Pedal, Brake
7	3146	Washer, Fiber	60	1847	Bolt, 1/4-20 x 1"
8	4491	Drum w/ Sprocket (inc. REF 9)	61	9502	Spring, Left Wound
9	3143	Bushing	62	9110	Bolt, 5/16-18 x 1-3/4"
10	3141	Snap Ring	63	1189	Nut, 5/16-18 Toplock
11	9001	Washer, 3/8 Int/Ext Lock	64	9796	Screw, 12-24 x 1/2" Self Tapping
12	1491	Bolt, 5/16-24 x 3/4"	65	1854	Washer, #14 Flat
13	3363-2	Bracket, Chainguard	66	9503	Spring, Right Wound
14	5135	Clip Nut	67	1849	Bolt, 1/4-20 x 1-1/2"
15	-----	-----	68	9780	Spring
16	9101	Bolt, 5/16-24 x 1/2"	69	5097	Brake Rod
17	3362	Chainguard	70	1846	Bolt, 1/4-20 x 3/4"
18	6039	Washer, #10 Lock	71	1982	Pedal Latch
19	6046	Screw, #10-24 x 1/2"	72	-----	-----
20	9186	Bolt, 5/16-18 x 1-1/2"	73	-----	-----
21	1046	Nut, 5/8-11 Toplock	74	-----	-----
ASM	2497	Front Wheel Assembly (inc. REF 22-28)	75	1263	Nut, 5/16-18 Flange
ASM	2247	Idle Wheel Asm (inc. REF 22-25,29-31)	76	1876	Bolt, 1/4-20 x 5/8" Whiz Flange
ASM	4337	Drive Wheel Asm (inc. REF 22-25,29-37)	77	-----	-----
22	1093	Bearing	78	1019	Ty-Wrap
23	5839	Bolt, 1/4-20 x 3/4"	ASM	9799	Stop Switch Assembly (inc. REF 79-81)
24	1186	Nut, 1/4-20	79	1392	Stop Switch
25	5949	Spanner	80	1393	Ring Terminal
26	5158	Wheel Half, Front 4"	81	1394	Wire, 50" w/Splice Connector
27	1053	Tube, Front 4"	82	3135	Blade Terminal
28	2244	Tire, Front 4.10/3.50 x 4" Knobby	83	-----	-----
29	8004	Wheel Half, Rear 5" Untapped	84	6038	Steering Wheel
30	1753	Tube, Rear 5"	85	9080	Bolt, 1/4-20 x 2-3/4"
31	2246	Tire, Rear 4.10/3.50 x 5" Knobby	86	9160	Bolt, 1/4-20 x 7/8"
32	8006	Wheel Half, Rear 5" Tapped	87	-----	-----
33	8008	Spacer	88	1463	Bushing, Insulating
34	2388	Nut, 3/8-24	89	6073	Chain, #35 x 72 Pitch (inc. REF 90)
35	8007	Sprocket, #35 Chain x 60 Teeth	90	1269	Master Link, #35 Chain
36	9030	Washer, 5/16 Lock	91	6221	Decal, Floor Pan (Starbird)
37	9127	Bolt, 5/16-18 x 2-1/4"		9329	Decal, Floor Pan (White Fox)
38	-----	-----	92	1049	Decal, Caution
39	-----	-----	93	4912	Decal, Warning
40	1937	Spacer, 5/8 ID x 1/4" Thick	94	6791	Decal, Oil Clutch
41	1264	Bolt, 1/2-13 x 3-1/2"	95	6621	Decal, Tire Pressure
42	1012	Nut, 1/2-13 Toplock	96	3296	Decal, Steering Wheel Cntr(Starbird)
43	8021	Spindle, Right Side		5946	Decal, Steering Wheel Cntr(White Fox)
NI	8020	Spindle, Left Side	NI	4350	Vehicle Operator's Manual
44	9085	Nut, 3/8-16 Toplock	NI	2600	Engine Owner's Manual
45	9146	Bolt, 3/8-16 x 1-1/2"	NI	9212R1	Assembly Instructions
ASM	4355	Tie Rod Assembly (inc. REF 46-50)	NI	5964	Decal, Oil Warning
46	1414	Tie Rod End, Right Hand Thread	NI	9677	Decal, Warning: Hot Surfaces
47	9092	Nut, 3/8-24 Jam, Right Hand Thread	NI	9678	Decal, Warning Engine Exhaust
48	1415	Tie Rod End, Left Hand Thread	NI	9679	Decal, No Passengers Allowed
49	9024	Nut, 3/8-24 Jam, Left Hand Thread			
50	4352	Tie Rod			
51	9006	Bolt, 1/4-20 x 1/2" Whiz Flange			
52	9091	Washer, 3/8 Flat			

ASM = Assembly  
NI = Not Illustrated

REF. NO.	PART NO.	DESCRIPTION
1	9554	Rear Bar, Sgl Seat *
	9553	Rear Bar, Dbl Seat *
2	9540-2	Front Bar, Sgl Seat
	9539-2	Front Bar, Dbl Seat
3	9549-2	Rear Upright Bar
4	9547-2	Center Bar, Sgl Seat
	9546-2	Center Bar, Dbl Seat
5	6320	Headrest Pad, Sgl Seat
	6217	Headrest Pad, Dbl Seat
6	6452	Bolt, 3/8-16 x 5"
7	2386	Bolt, 3/8-16 x 3-1/2"
8	2264	Bolt, 5/16-18 x 3/4"
9	1876	Bolt, 1/4-20 x 5/8"
10	9085	Nut, 3/8-16 Toplock
11	1189	Nut, 5/16-18 Toplock
12	9776	Clamp, Foam Stop, 3/4"

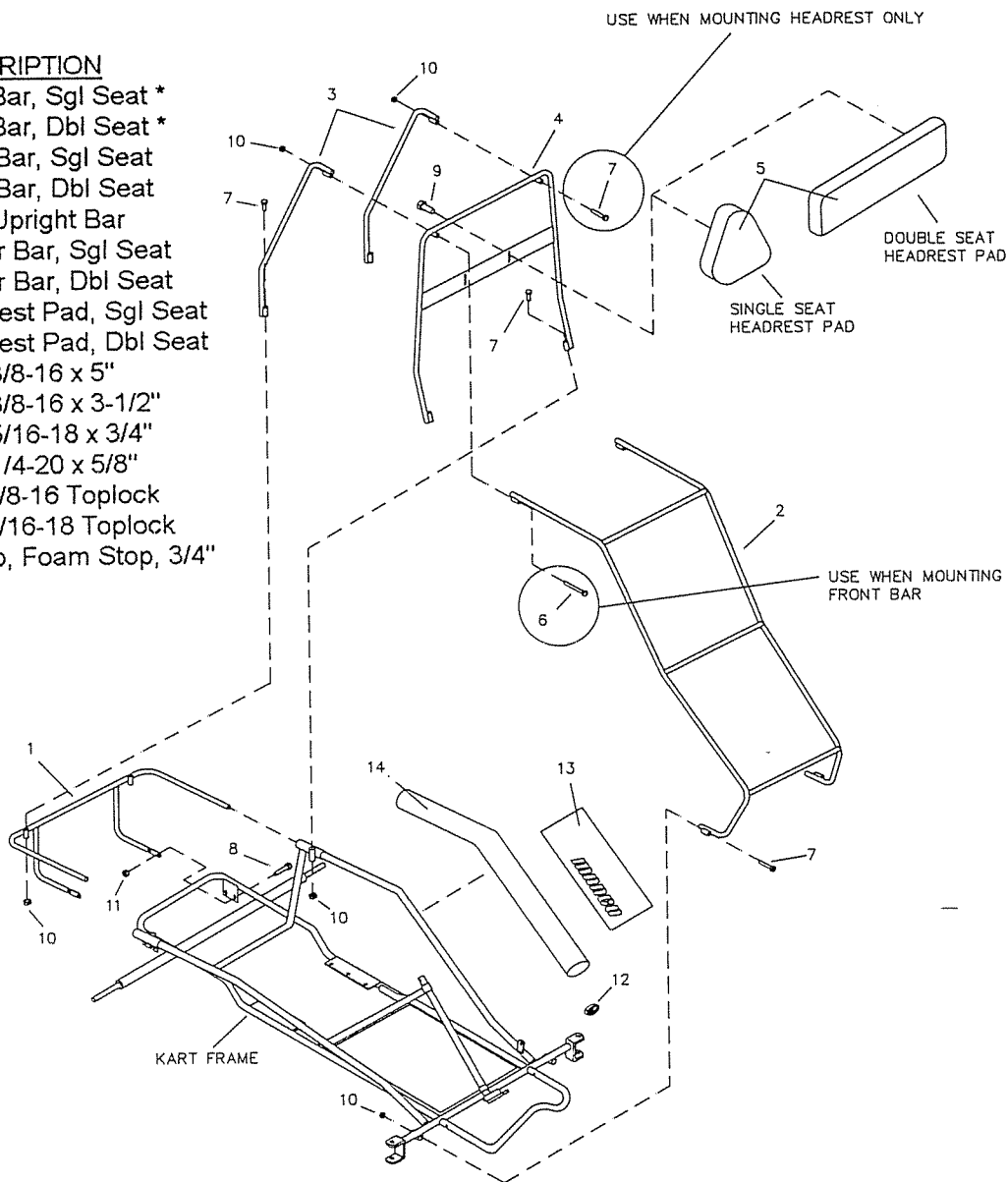

13	9800	Arm Pad Cover, MANCO
	9797	Arm Pad Cover, Phoenix
14	9759	Foam, Side Bar, 30" **
15	9758	Foam, Front Bar, 43" **
16	9763	Foam, 16" Sgl Seat **
	9760	Foam, 22" Dbl Seat **
17	9764	Foam, 15" Sgl Seat **
	9761	Foam, 21" Dbl Seat **
18	9765	Foam, 14" Sgl Seat **
	9762	Foam, 20" Dbl Seat **
NI	9798	Foam Kit, Universal **

\* = Specify Color

\*\* = Foam Part Numbers are followed by one of the following Color Designating Suffixes:

B - Black

P - Pink

W - White

Y - Yellow

Specify Color Suffix when ordering replacement foam.

NI = Not Illustrated

NOTE: Arm Pad Cover (REF. 13) is an optional part. It is not included with all Manco Kart Models.

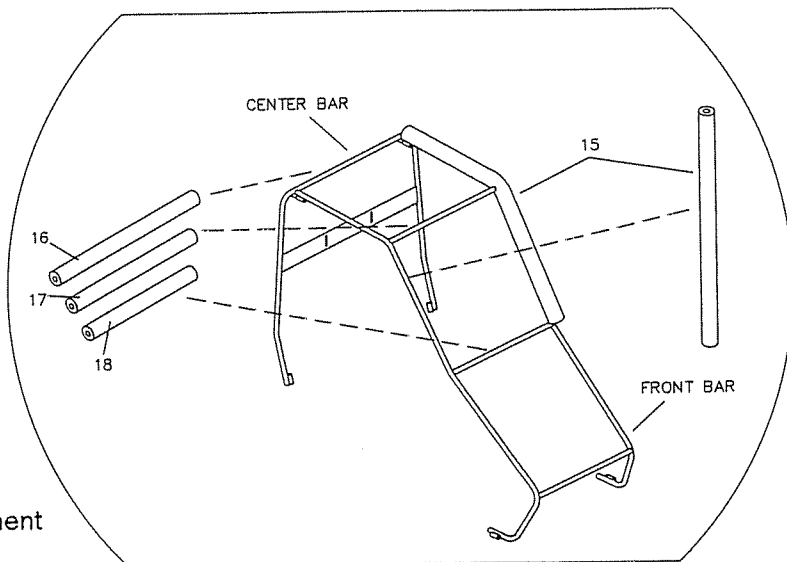

# THROTTLE CABLE INSTALLATION

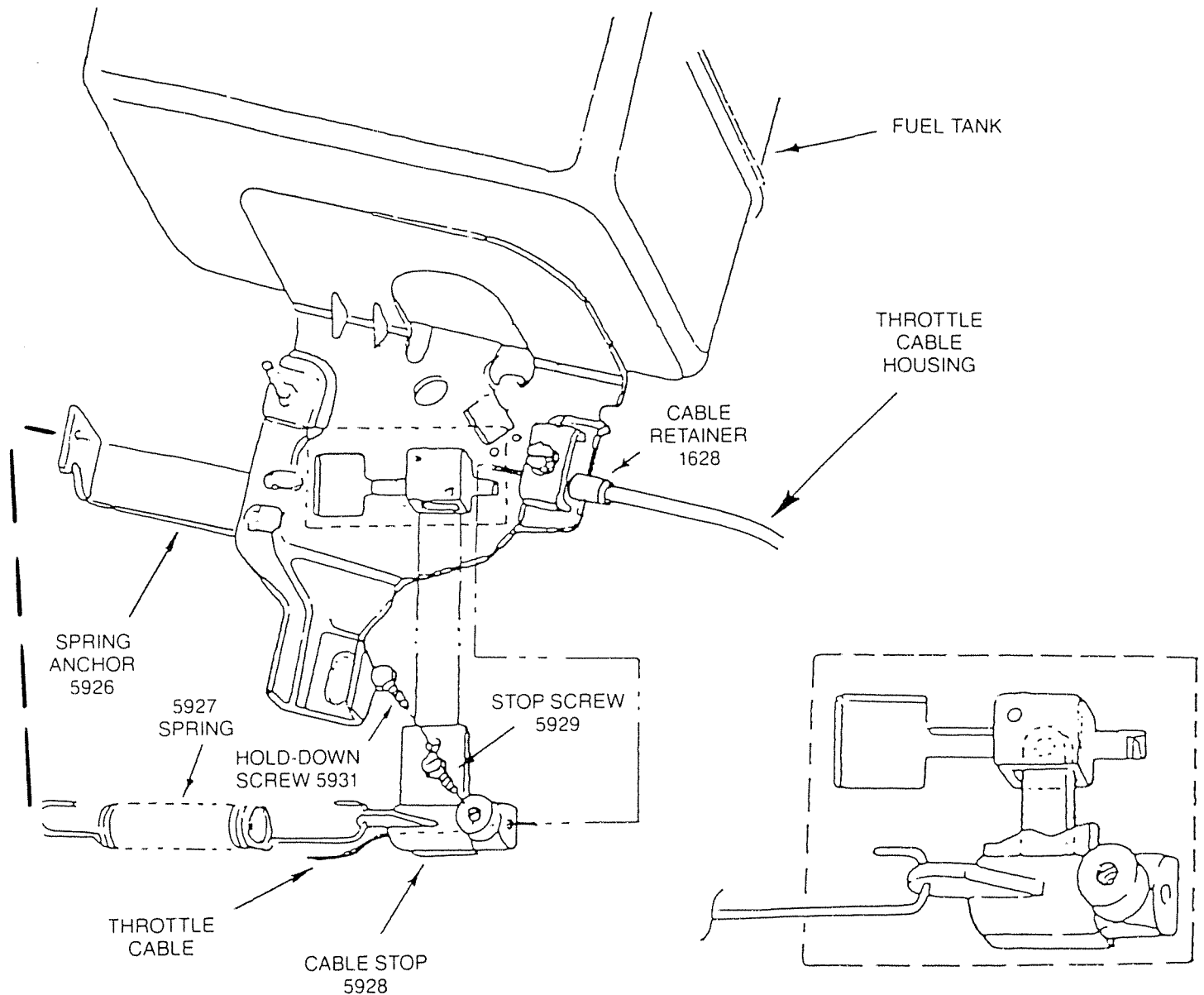

**ASSEMBLY:** Pass the throttle cable through the cable retainer and butt the throttle cable housing end against the inside shoulder of the cable retainer. (The cable retainer is to be securely fastened to the engine with the clamping screw.) Pass the end of the Throttle Cable through the hole in the cable stop. Before tightening cable stop screw:

1. Ensure spring anchor, spring, and cable are installed as illustrated above.
2. Ensure throttle pedal is in rearward (idle) position.
3. Ensure that there is no slack in the throttle cable with *no* tension applied to return spring.
4. Ensure cable housing is inside and against the cable retainer.