

# Operator's Manual SUPPLEMENT

MANCO MODEL NO.  
415-081

**WARNING:**  
Read Engine  
Owner's Manual,  
Vehicle Operator's  
Manual, and  
Supplement  
Carefully Before  
Operating  
Vehicle.

**Parts List**

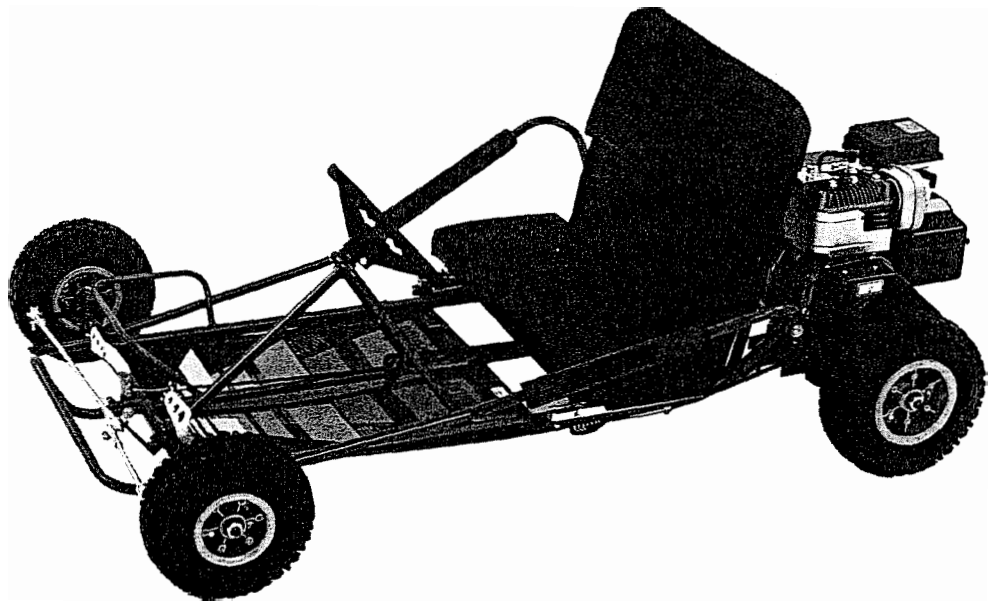

## ORDERING PARTS

FAST & EASY!

- 1) Seek Part(s) from your models illustrated diagram, cross over REF# to PART#
- 2) Type PART# into sites [Search Box] at [GoKartsRus.com](http://GoKartsRus.com) TIP! - RIGHT CLICK LINK, SELECT OPEN IN NEW TAB
- 3) Add all needed parts to Shopping Cart | Complete "Checkout" | ✓ Done!

If a part does not come up in a Site Search, please [Contact Us](#) (include part# in email)

LOWEST PRICES!

BEFORE OPERATING THIS VEHICLE, THE OWNER AND/OR OPERATOR MUST UNDERSTAND THE VEHICLE WAS NOT DESIGNED OR MANUFACTURED TO MEET SPECIFICATIONS FOR USE ON PUBLIC ROADS, STREETS, HIGHWAYS, OR THOROUGHFARES AND HAVE READ AND HAVE AN UNDERSTANDING OF ALL THE INSTRUCTIONS FOR SAFE ASSEMBLY AND OPERATION AS WELL AS THE INSTRUCTIONS GOVERNING THE ENGINE AND OTHER PORTIONS OF THE VEHICLE.

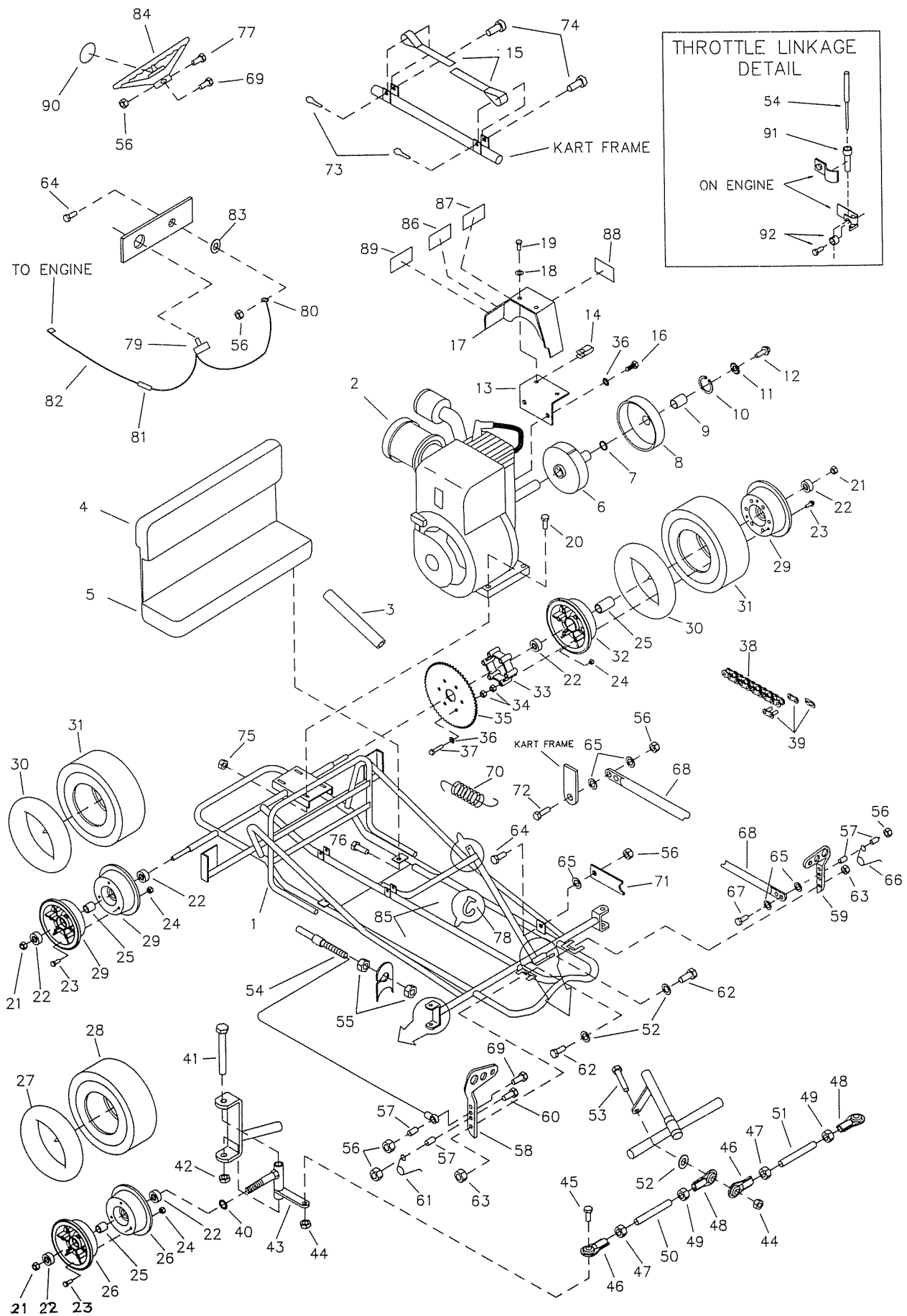

## REPAIR PARTS - MODEL 415-081

REF NO.	PART NO.	DESCRIPTION	REF NO.	PART NO.	DESCRIPTION
	1	3318-19	53	9145	Bolt, 3/8-16 x 1.75"
	2	1763	54	1390	Throttle Cable w/ Housing (inc. REF 55)
	3	5945	55	9058	Nut, 5/16-24 Jam
	4	4328	56	9057	Nut, 1/4-20 Toplock
	5	4327	57	1389	Bushing
<b>ASM</b>	4335	Clutch Assembly (inc. REF 6-10)	58	1437	Pedal, Throttle
	6	4496	59	1436	Pedal, Brake
	7	3146	60	1847	Bolt, 1/4-20 x 1.00"
	8	4491	61	9502	Spring, Left Wound
	9	3143	62	9110	Bolt, 5/16-18 x 1.75"
	10	3141	63	1189	Nut, 5/16-18 Toplock
	11	9001	64	1845	Bolt, 1/4-20 x .625"
	12	1491	65	1854	Washer, #14 Flat
	13	3363-2	66	9503	Spring, Right Wound
	14	5135	67	1849	Bolt, 1/4-20 x 1.50"
	15	4372	68	5097	Brake Rod
	16	9101	69	9160	Bolt, 1/4-20 x .875"
	17	3362	70	4365	Spring
	18	6039	71	1982	Pedal Latch
	19	6046	72	1846	Bolt, 1/4-20 x .75"
	20	9186	73	9116	Cotter Pin
	21	1046	74	9118	Clevis Pin
<b>ASM</b>	2497	Front Wheel Assembly (inc. REF 22-28)	75	1263	Nut, 5/16-18 Flange
<b>ASM</b>	2247	Idle Wheel Asm (inc. REF 22-25,29-31)	76	1876	Bolt, 1/4-20 x .625"
<b>ASM</b>	9474	Drive Wheel Asm (inc. REF 22-25,29-37)	77	9080	Bolt, 1/4-20 x 2.75"
	22	1093	78	1019	Ty-Wrap
	23	5839	<b>ASM</b>	4419	Stop Switch Assembly (inc. REF 79-82)
	24	1186	79	1392	Stop Switch
	25	5949	80	1393	Ring Terminal
	26	5158	81	2650	Butt Connector
	27	1053	82	5642	Wire w/ Terminal
	28	2244	83	5732	Washer, 1/4 Int/Ext Lock
	29	8004	84	6038	Steering Wheel
	30	1753	85	5944	Decal, Floor Pan (L & R)
	31	2246	86	1049	Decal, Caution
	32	8006	87	4912	Decal, Warning
	33	8008	88	6791	Decal, Oil Clutch
	34	2388	89	6612	Decal, Tire Pressure
	35	8007	90	5946	Decal, Steering Wheel Center
	36	9030	91	1628	Throttle Cable Retainer
	37	2383	92	1018	Throttle Cable Stop
	38	8050	<b>NI</b>	4350	Vehicle Operator's Manual
	39	1269	<b>NI</b>	2684B	Engine Owner's Manual
	40	1937			
	41	1264			
	42	1012			
	43	8021			
	<b>NI</b>	8020			
	44	9085			
	45	9146			
<b>ASM</b>	4359	Tie Rod Assembly (inc. REF 46-50)			
<b>ASM</b>	4358	Tie Rod Assembly (inc. REF 46-49,51)			
	46	1414			
	47	9092			
	48	1415			
	49	9024			
	50	5003			
	51	4356			
	52	9091			

**ASM** = Assembly  
**NI** = Not Illustrated

