

# Operator's Manual SUPPLEMENT

MANCO MODEL NO.  
415-10

**WARNING:**  
Read Engine  
Owner's Manual,  
Vehicle Operator's  
Manual, and  
Supplement  
Carefully Before  
Operating  
Vehicle.

Parts List



## ORDERING PARTS

**FAST & EASY!**

- 1) Seek Part(s) from your models illustrated diagram, cross over REF# to PART#
- 2) Type PART# into sites [Search Box] at [GoKartsRus.com](http://GoKartsRus.com) TIP! - RIGHT CLICK LINK, SELECT OPEN IN NEW TAB
- 3) Add all needed parts to Shopping Cart | Complete "Checkout" | ✓ Done!

If a part does not come up in a Site Search, please [Contact Us](#) (include part# in email)

**LOWEST PRICES!**

BEFORE OPERATING THIS VEHICLE, THE OWNER AND/OR OPERATOR MUST UNDERSTAND THE VEHICLE WAS NOT DESIGNED OR MANUFACTURED TO MEET SPECIFICATIONS FOR USE ON PUBLIC ROADS, STREETS, HIGHWAYS, OR THOROUGHFARES AND HAVE READ AND HAVE AN UNDERSTANDING OF ALL THE INSTRUCTIONS FOR SAFE ASSEMBLY AND OPERATION AS WELL AS THE INSTRUCTIONS GOVERNING THE ENGINE AND OTHER PORTIONS OF THE VEHICLE.

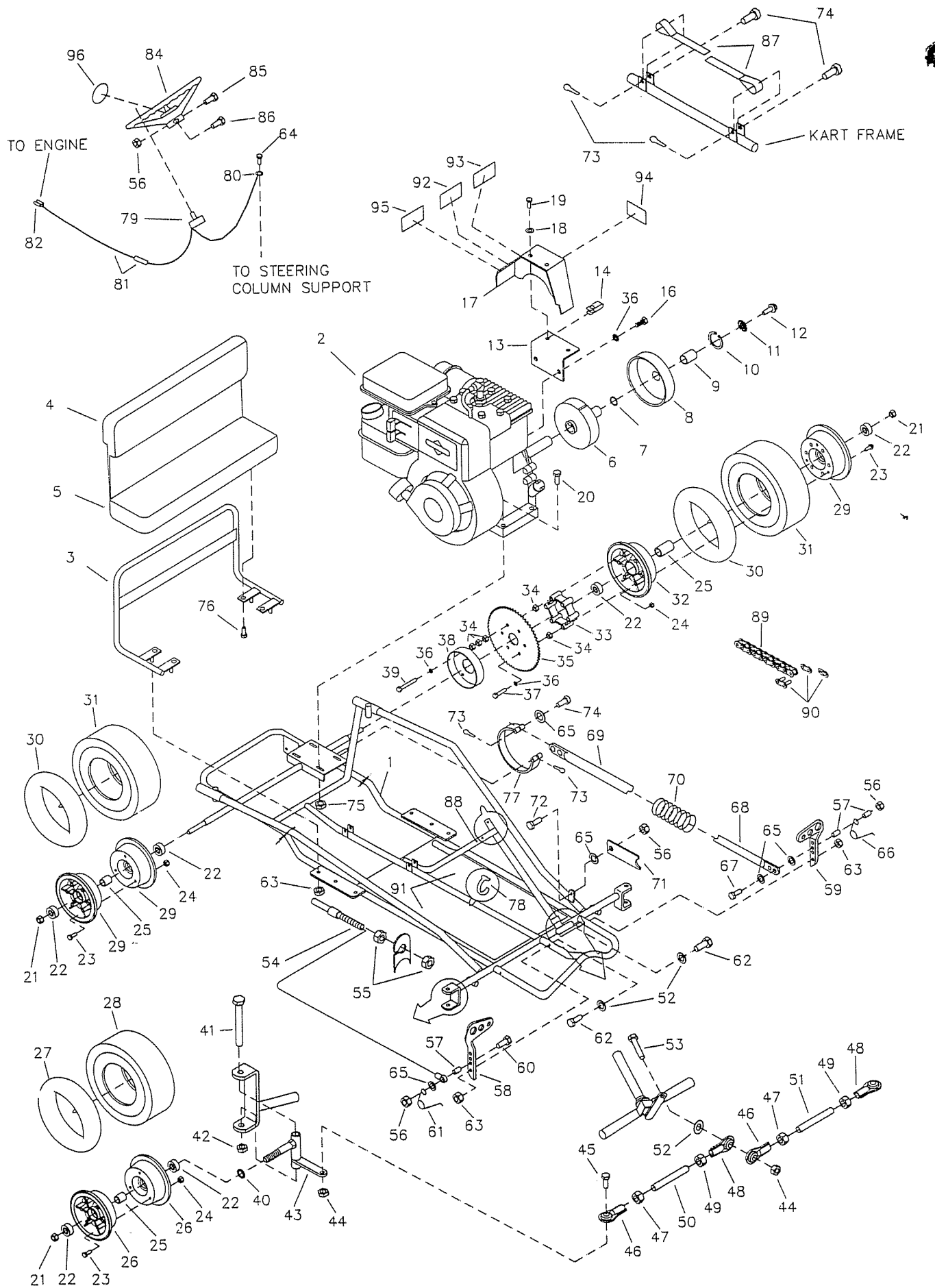

## REPAIR PARTS - MODEL 415-10

REF NO.	PART NO.	DESCRIPTION	REF NO.	PART NO.	DESCRIPTION
1	9573-19	Frame	53	9145	Bolt, 3/8-16 x 1-3/4"
2	6010	Engine, 5hp	54	1390	Throttle Cable w/ Housing (inc. REF 55)
3	3325-2	Seat Frame	55	9058	Nut, 5/16-24 Jam
4	4328	Seat Back	56	9057	Nut, 1/4-20 Toplock
5	4327	Seat Bottom	57	1389	Bushing
<b>ASM</b>	4335	Clutch Assembly (inc. REF 6-10)	58	1437	Pedal, Throttle
6	4496	Clutch Rotor	59	1436	Pedal, Brake
7	3146	Washer, Fiber	60	1847	Bolt, 1/4-20 x 1"
8	4491	Drum w/ Sprocket (inc. REF 9)	61	9502	Spring, Left Wound
9	3143	Bushing	62	9110	Bolt, 5/16-18 x 1-3/4"
10	3141	Snap Ring	63	1189	Nut, 5/16-18 Toplock
11	9001	Washer, 3/8 Int/Ext Lock	64	9796	Screw, 12-24 x 1/2" Self Tapping
12	1491	Bolt, 5/16-24 x 3/4"	65	1854	Washer, #14 Flat
13	3363-2	Bracket, Chainguard	66	9503	Spring, Right Wound
14	5135	Clip Nut	67	1849	Bolt, 1/4-20 x 1-1/2"
15	-----	-----	68	2377	Brake Rod, Front
16	9101	Bolt, 5/16-24 x 1/2"	69	4351	Brake Rod, Rear
17	3362	Chainguard	70	9709	Spring
18	6039	Washer, #10 Lock	71	1982	Pedal Latch
19	6046	Screw, #10-24 x 1/2"	72	1846	Bolt, 1/4-20 x 3/4"
20	9186	Bolt, 5/16-18 x 1-1/2"	73	9116	Cotter Pin
21	1046	Nut, 5/8-11 Toplock	74	9118	Clevis Pin
<b>ASM</b>	2497	Front Wheel Assembly (inc. REF 22-28)	75	1263	Nut, 5/16-18 Flange
<b>ASM</b>	2247	Idle Wheel Asm (inc. REF 22-25,29-31)	76	9189	Bolt, 1/4-20 x 7/8"
<b>ASM</b>	4371	Drive Wheel Asm (inc. REF 22-25,29-39)	77	1036	Brake Band
22	1093	Bearing	78	1019	Ty-Wrap
23	5839	Bolt, 1/4-20 x 3/4"	<b>ASM</b>	9799	Stop Switch Assembly (inc. REF 79-81)
24	1186	Nut, 1/4-20	79	1392	Stop Switch
25	5949	Spanner	80	1393	Ring Terminal
26	5158	Wheel Half, Front 4"	81	1394	Wire, 50" w/ Splice Connector
27	1053	Tube, Front 4"	82	3135	Blade Terminal, Female
28	2244	Tire, Front 4.10/3.50 x 4" Knobby	83	-----	-----
29	8004	Wheel Half, Rear 5" Untapped	84	6038	Steering Wheel
30	1753	Tube, Rear 5"	85	9080	Bolt, 1/4-20 x 2-3/4"
31	2246	Tire, Rear 4.10/3.50 x 5" Knobby	86	9160	Bolt, 1/4-20 x 7/8"
32	8006	Wheel Half, Rear 5" Tapped	87	4372	Handhold Strap
33	8008	Spacer	88	1463	Bushing, Insulating
34	2388	Nut, 3/8-24	89	6073	Chain, #35 x 72 Pitch (inc. REF 90)
35	8007	Sprocket, #35 Chain x 60 Teeth	90	1269	Master Link, #35 Chain
36	9030	Washer, 5/16 Lock	91	4341	Decal, Floor Pan (L & R)
37	9127	Bolt, 5/16-18 x 2-1/4"	92	1049	Decal, Caution
38	1246	Brake Drum	93	4912	Decal, Warning
39	9000	Bolt, 5/16-18 x 3-1/2"	94	6791	Decal, Oil Clutch
40	1937	Spacer, 5/8 ID x 1/4" Thick	95	6621	Decal, Tire Pressure
41	1264	Bolt, 1/2-13 x 3-1/2"	96	3296	Decal, Steering Wheel Center
42	1012	Nut, 1/2-13 Toplock	<b>NI</b>	4350	Vehicle Operator's Manual
43	8021	Spindle, Right Side	<b>NI</b>	2601	Engine Owner's Manual
<b>NI</b>	8020	Spindle, Left Side	<b>NI</b>	9212R1	Assembly Instructions
44	9085	Nut, 3/8-16 Toplock	<b>NI</b>	9677	Decal, Hot Surfaces
45	9146	Bolt, 3/8-16 x 1-1/2"	<b>NI</b>	9678	Decal, Warning: Engine Exhaust
<b>ASM</b>	4359	Tie Rod Assembly (inc. REF 46-50)	<b>NI</b>	9679	Decal, No Riders Allowed
<b>ASM</b>	4358	Tie Rod Assembly (inc. REF 46-49,51)	<b>NI</b>	5964	Decal, Oil Warning
46	1414	Tie Rod End, Right Hand Thread			
47	9092	Nut, 3/8-24 Jam, Right Hand Thread			
48	1415	Tie Rod End, Left Hand Thread			
49	9024	Nut, 3/8-24 Jam, Left Hand Thread			
50	5003	Tie Rod, Long			
51	4356	Tie Rod, Short			
52	9091	Washer, 3/8 Flat			

**ASM** = Assembly  
**NI** = Not Illustrated

REF. NO.	PART NO.	DESCRIPTION
1	9554	Rear Bar, Sgl Seat *
	9553	Rear Bar, Dbl Seat *
2	9540-2	Front Bar, Sgl Seat
	9539-2	Front Bar, Dbl Seat
3	9549-2	Rear Upright Bar
4	9547-2	Center Bar, Sgl Seat
	9546-2	Center Bar, Dbl Seat
5	6320	Headrest Pad, Sgl Seat
	6217	Headrest Pad, Dbl Seat
6	6452	Bolt, 3/8-16 x 5"
7	2386	Bolt, 3/8-16 x 3-1/2"
8	2264	Bolt, 5/16-18 x 3/4"
9	1876	Bolt, 1/4-20 x 5/8"
10	9085	Nut, 3/8-16 Toplock
11	1189	Nut, 5/16-18 Toplock
12	9776	Clamp, Foam Stop, 3/4"

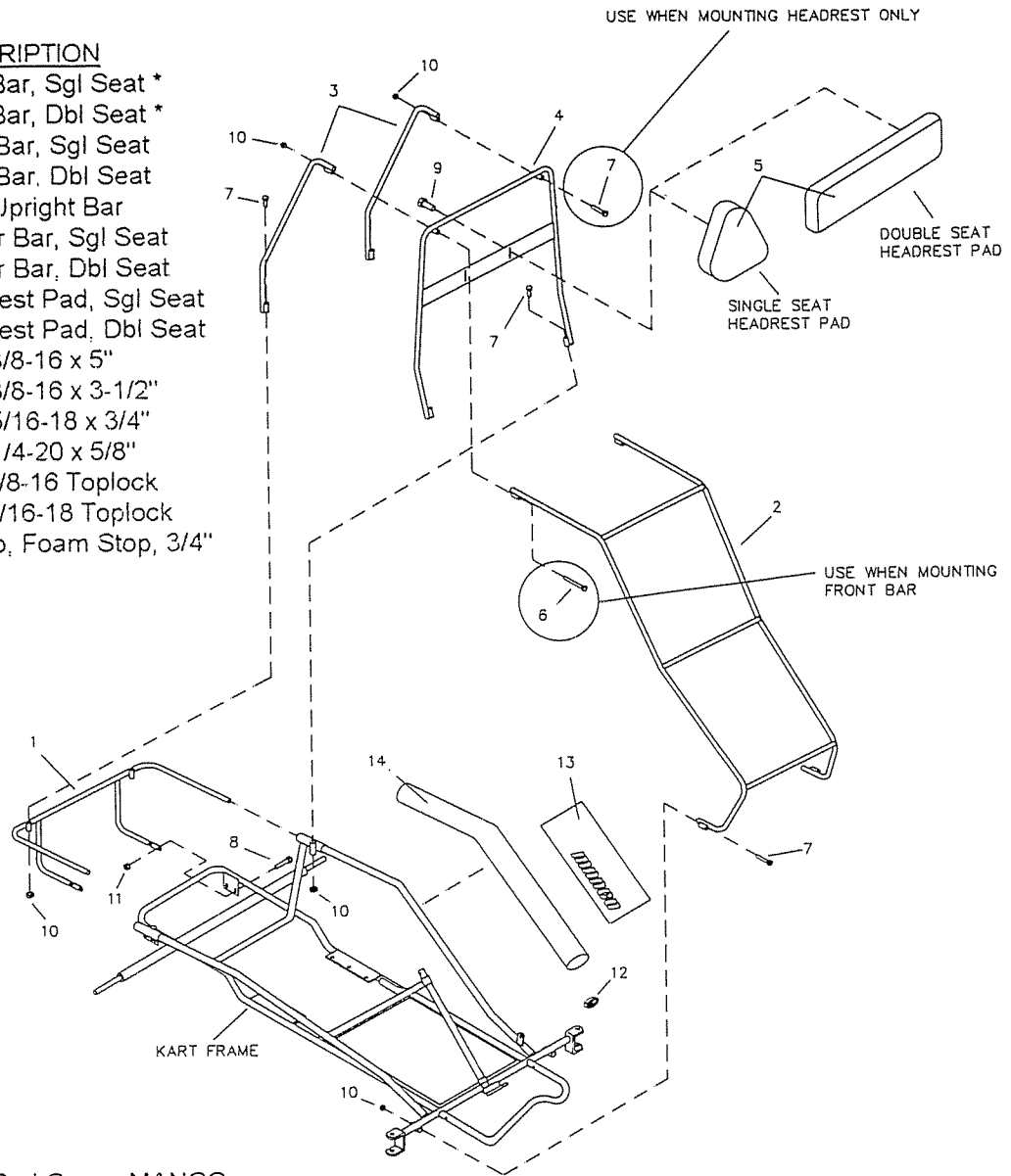

13	9800	Arm Pad Cover, MANCO
	9797	Arm Pad Cover, Phoenix
14	9759	Foam, Side Bar, 30" **
15	9758	Foam, Front Bar, 43" **
16	9763	Foam, 16" Sgl Seat **
	9760	Foam, 22" Dbl Seat **
17	9764	Foam, 15" Sgl Seat **
	9761	Foam, 21" Dbl Seat **
18	9765	Foam, 14" Sgl Seat **
	9762	Foam, 20" Dbl Seat **
NI	9798	Foam Kit, Universal **

\* = Specify Color

\*\* = Foam Part Numbers are followed by one of the following Color Designating Suffixes:

B - Black

P - Pink

W - White

Y - Yellow

Specify Color Suffix when ordering replacement foam.

NI = Not Illustrated

NOTE: Arm Pad Cover (REF. 13) is an optional part. It is not included with all Manco Kart Models.

