

Operator's Manual
SUPPLEMENT
Model Nos.
485B-0 & 486B-0

⚠ WARNING:

Read Engine
Owner's Manual,
Vehicle Operator's
Manual, and
Supplement
Carefully Before
Operating Vehicle.

Parts List



ORDERING PARTS

FAST & EASY!

- 1) Seek Part(s) from your models illustrated diagram, cross over REF# to PART#
- 2) Type PART# into sites [Search Box] at GoKartsRus.com TIP! - RIGHT CLICK LINK, SELECT OPEN IN NEW TAB
- 3) Add all needed parts to Shopping Cart | Complete "Checkout" | ✓ Done!

If a part does not come up in a Site Search, please [Contact Us](#) (include part# in email)

LOWEST PRICES!

**THIS VEHICLE IS FOR
OFF-ROAD USE ONLY**

BEFORE OPERATING THIS VEHICLE, THE OWNER AND/OR OPERATOR MUST UNDERSTAND THE VEHICLE WAS NOT DESIGNED OR MANUFACTURED TO MEET SPECIFICATIONS FOR USE ON STREETS, HIGHWAYS, OR THOROUGHFARES AND HAVE READ AND HAVE AN UNDERSTANDING OF ALL THE INSTRUCTIONS FOR SAFE ASSEMBLY AND OPERATION AS WELL AS THE INSTRUCTIONS GOVERNING THE ENGINE AND OTHER PORTIONS OF THE VEHICLE.

PARTS LIST MODELS 485B-0 & 486B-0

REF	PN	DESCRIPTION
1	10527-2	FRAME WELDMNT, BLACK
ASM	10869	TIE ROD ASM LONG (INCL. 2, 4-7)
ASM	5020	TIE ROD ASM SHORT (INCL. 3-7)
2	10868	TIE ROD 19.0
3	5004	TIE ROD 7.25
4	1415	TIE ROD END LH THREAD
5	1414	TIE ROD END RH THREAD
6	9024	NUT, 3/8-24 JAM LH THREAD
7	9092	NUT, 3/8-24 JAM RH THREAD
8	9674	SPACER, 3/8 ID X 3/8 LONG
9	9146	BOLT, 3/8-16 X 1.50
10	9158	BOLT, 3/8-16 X 2.25
11	9006	BOLT, 1/4-20 X .50 HEX FLANGED WHIZ
NI	10548-2Z	SPINDLE WELDMNT LEFT BLACK
12	10549-2Z	SPINDLE WELDMNT RIGHT BLACK
13	9709	COMPRESSION SPRING
14	5682	BOLT, 1/2-13 X 5.500
15	1012	NUT, 1/2-13 TOPLOCK
16	1046	NUT, 5/8-11 TOPLOCK
17	1104	SPACER SPLIT .812OD .625ID 1.000L
18	9309FP	WHEEL ASSEMBLY, IDLE (INCL. 19-22)
19	4915	TIRE 145/70 X 6" KNOBBY
20	3802	INNER TUBE 6" (REPAIR PART ONLY)
21	5090	BEARING, 5/8" I.D.
22	5950	SPANNER, 5/8" I.D. X 2-1/8"
23	6289PH	WHEEL ASM 16/8 X 7 HEX BLACK
24	9607	TIRE, 16/8 X 7 KNOBBY
25	9609	TUBE 16/8.0 X 7 (REPAIR PART ONLY)
26	9323H	AXLE WELDMNT HEX 39-1/4"
27	3941H	BEARING, SEALED 7/8" HEX
28	1760	BEARING FLANGE
29	1448-16	SPACER, 1" I.D. X 3-9/16"
30	2265-16	SPACER, 1" I.D. X 3/4"
31	9085	NUT, 3/8-16 TOPLOCK HEX
32	1119	SPACER .625ID 1.062OD .125THK Z
33	4913-16	SPACER, 1" I.D. X 3"
34	6309-16	PEDAL, THROTTLE TRIMMED
35	9503	SPRING, PEDAL RIGHT WOUND
36	9929	RUBBER CAP .25ID X .25 BLACK
37	8251	THROTTLE CABLE 74.50 INCH
38	2748	CABLE STOP NUT
39	2666	SWIVEL SCREW
40	6293-16	PEDAL, BRAKE TRIMMED
41	9502	SPRING, PEDAL LEFT WOUND

REF	PN	DESCRIPTION
42	1848	BOLT, 1/4-20 X 1.25"
43	6349	BUSHING, 5/16 OD X 22G
44	1389	BUSHING, 1/4 ID X .313
45	1447	BOLT, 3/8 X 1-1/8 SHOULDER
46	9091	WASHER, FLAT 3/8 SAE N
47	9599-2	BRAKE ROD BLACK
48	1847	BOLT, 1/4-20 X 1"
49	9598	BRAKE CALIPER ASSEMBLY
50	9118	PIN, CLEVIS 1/4 X 1.250 Z
51	9116	PIN, COTTER 3/32 X .750 Z
52	6038	STEERING WHEEL
53	9799	STOP SWITCH WIRE ASM
NI	1406	STOP SWITCH WIRE EXTENSION
54	9080	BOLT, 1/4-20 X 2.750
55	9160	BOLT, 1/4-20 X .875
56	9796	BOLT, #12-24 X .500 SELF TAPPING
57	6320	HEADREST PAD
58	8370	SEAT BACK/BOTTOM
59	1263	NUT 5/16-18 HEX FLANGED WHIZ
60	9515	CHAIN, 420P X 64 LINKS
61	2037	MASTERLINK 420 CHAIN
62	1982	PEDAL LATCH, BLACK
63	1846	BOLT, 1/4-20 X .750
64	9057	NUT, 1/4-20 TOPLOCK
65	1854	WASHER, #14 FLAT MS Z
66	4372	HANDHOLD STRAP
67	-----	
68	6280H	SPROCKET HUB HEX
69	9338	SPROCKET, 420 X 60 TEETH
70	6701	BOLT 5/16-18 X 1.250 SHCS
71	9511H	BRAKE DISK
72	9162	NUT, 3/4" TOPLOCK HEX
73	11329	DECAL SHEET, CENTER BAR WARNINGS
74	11330	DECAL SHEET, ENGINE AND MAIN FRAME WARNINGS
75	8187	DRIVE COVER, TC/LA
76	5959	DRIVE BELT
77	8373	SEAT BELT - SHOULDER/LAP
78	K485	AXLE GUARD KIT
79	9188	BOLT, 1/2-13 X 1.50
80	9022	WASHER, 1/2 FLAT
81	2386	BOLT, 3/8-16 X 3.50
82	5287	BOLT #10-16 X .375 SELF TAPPING

REF	PN	DESCRIPTION
83	5288	WIRE CLAMP
84	1189	NUT, 5/16-18 HEX TOPLOCK
85	9189	BOLT, 1/4-20 X .875 WHIZ FLANGE
86	1876	BOLT 1/4-20 X .625 WHIZ FLANGE
87	9968-2	SEAT FRAME WELDMNT BLACK
88	6734	SEAT SLIDE PR - SHORT
89	8445	FLAG SAFETY W/ BRKT 3FT
90	9661C	ENGINE 5HP TEC OHV (485B-0)
	5533	ENGINE 6HP TEC OHV (486B-0)
ASM	5957	DRIVER PULLEY ASM (INCL. 91-96)
91	----	STATIONARY SHEAVE
92	200349	BUSHING
93	----	MOVEABLE SHEAVE
94	----	SHOE ASSEMBLY
95	----	HUB
96	----	DRUM
97	1938	SPACER, 3/4" I.D. X 3/8" LONG
98	1398	WASHER, 21/64 ID X 1 1/4 X 1/8
99	1124	WASHER, 5/16" SPLITLOCK
100	8204	BOLT, 5/16-24 X 2-1/4"
101	9101	BOLT, 5/16-24 X .500 W/ NYLOK
102	2264	BOLT, 5/16-18 X 3/4" LONG
103	1194	WASHER, 3/4" SAE FLAT
104	9060	WASHER, 5/16 FLAT
105	8227	NUT, 1/4-20 TINNEMAN
106	8188	PLATE, COVER 4XX TC BLACK
107	10537-2	OVERHEAD BAR WELDMNT BLACK
108	10544-2	CENTER BAR WELDMNT BLACK
109	10541-2	REAR BAR WELDMNT BLACK
NI	1019	CABLE TIE
NI	8746M	SAFETY VIDEO
NI	4350	OPERATOR'S MANUAL

ASM = ASSEMBLY
NI = NOT ILLUSTRATED

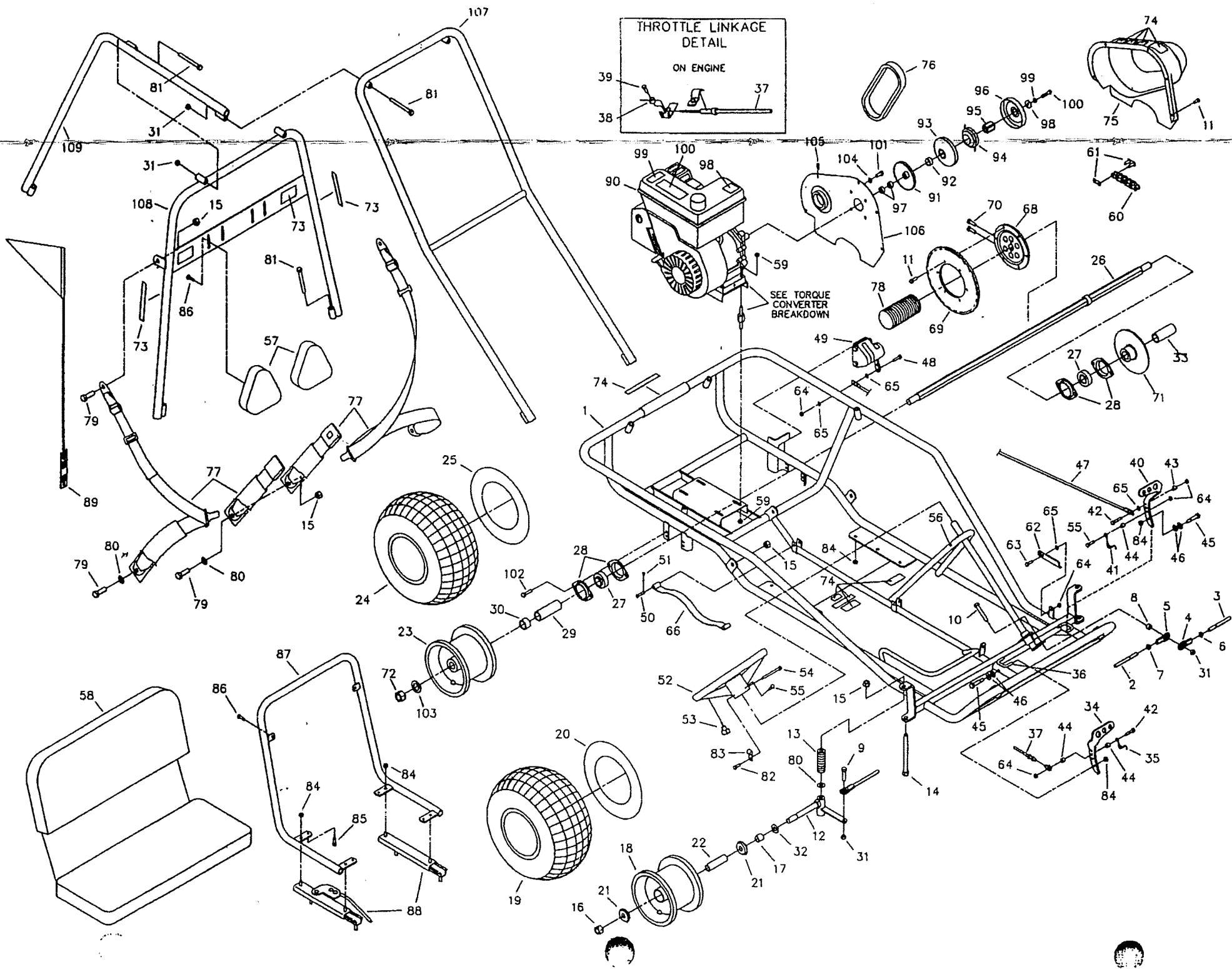

Addendum to Parts List

Please use the part numbers listed when ordering the parts identified below for your Manco Model 486C-0

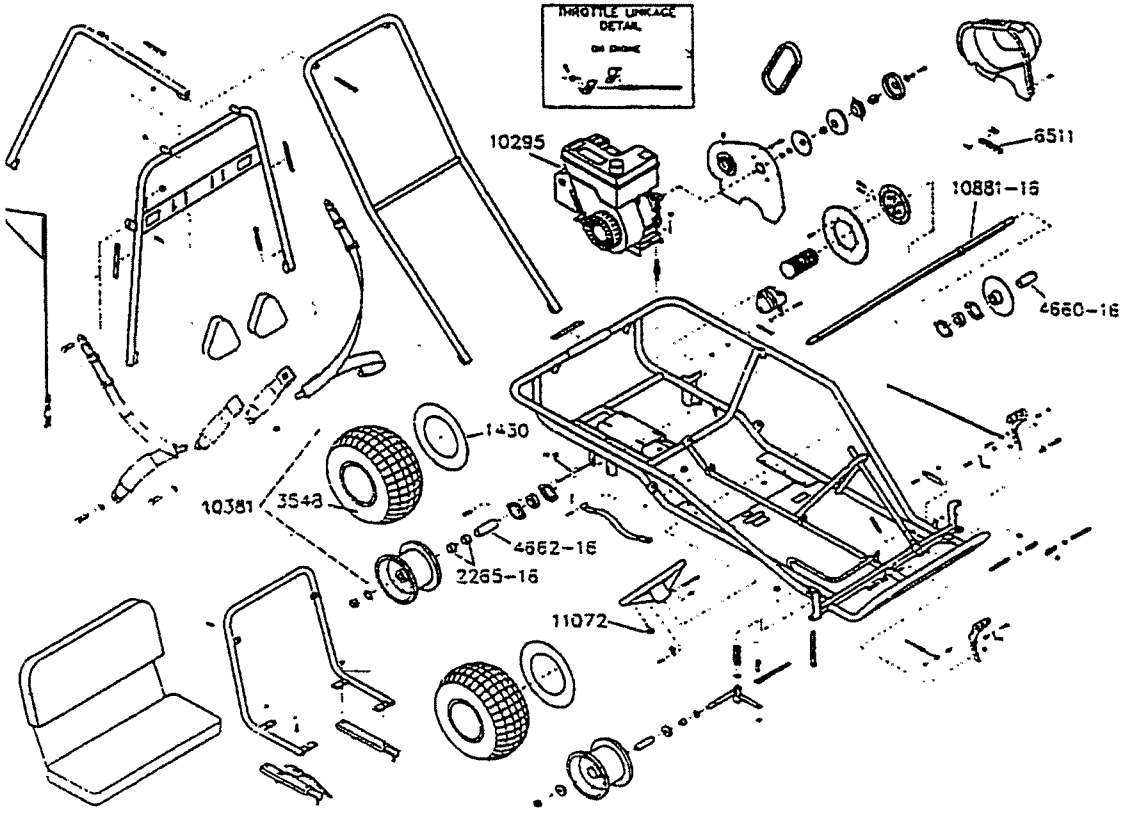

PN	Description
10295	Engine 6hp w/coil
10381	Wheel Asm incl 3548
10881-16	Axle
11072	Stop Switch Asm
1430	Tube, 8"
2265-16	Spacer, 1" x 3/4"
3548	Tire, 18-9.5 x 8
4660-16	Spacer, 1" x 4-7/16"
4662-16	Spacer, 1" x 4-1/4"
6511	Chain, 420P x 66 Link

Not Illustrated

11344 Running Light Kit

** - Axle is mounted in the lower holes of the bearing flange mounting brackets.

9271S1
4/2000

Addendum to Parts List

Please use the part numbers listed when ordering the parts identified below for your Manco Model 486C-0

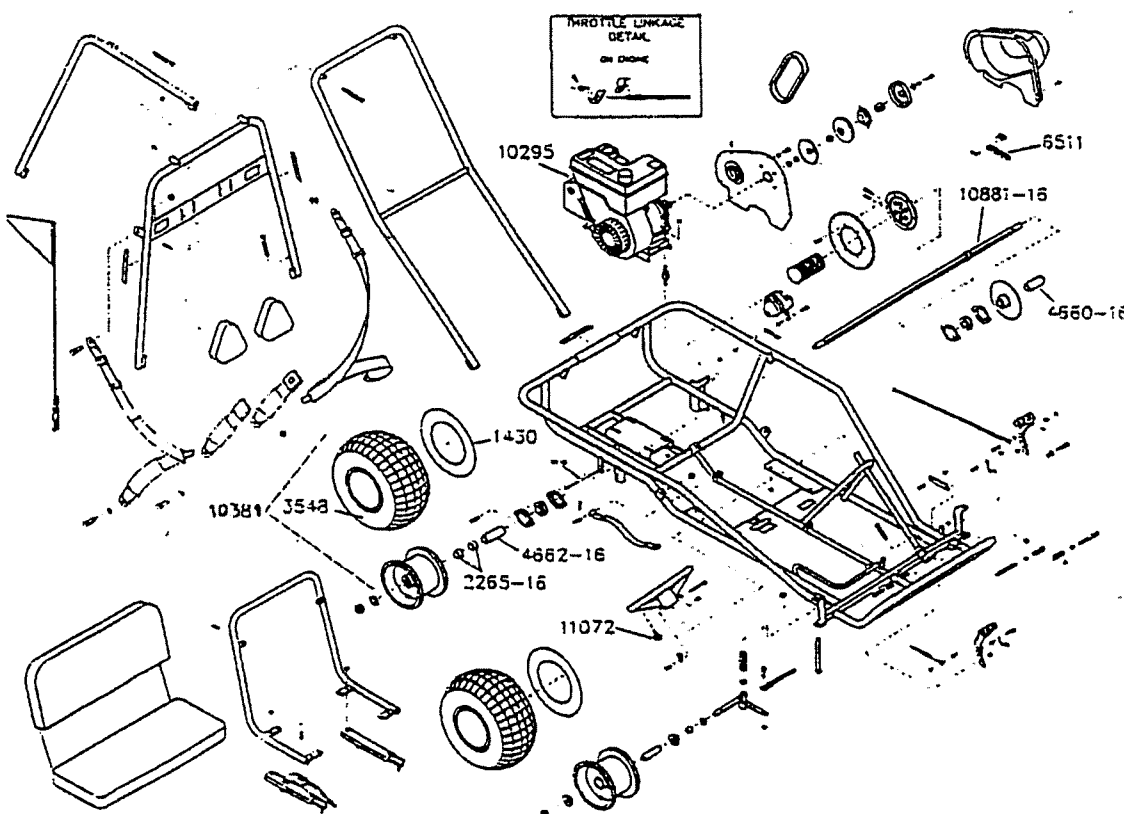

PN	Description
10295	Engine 6hp w/coil
10381	Wheel Asm incl 3548
10881-16	Axle
11072	Stop Switch Asm
1430	Tube, 8"
2265-16	Spacer, 1" x 3/4"
3548	Tire, 18-9.5 x 8
4660-16	Spacer, 1" x 4-7/16"
4662-16	Spacer, 1" x 4-1/4"
6511	Chain, 420P x 66 Link

Not Illustrated

11344 Running Light Kit

** - Axle is mounted in the lower holes of the bearing flange mounting brackets.

9271S1
4/2000

CALIPER BREAKDOWN

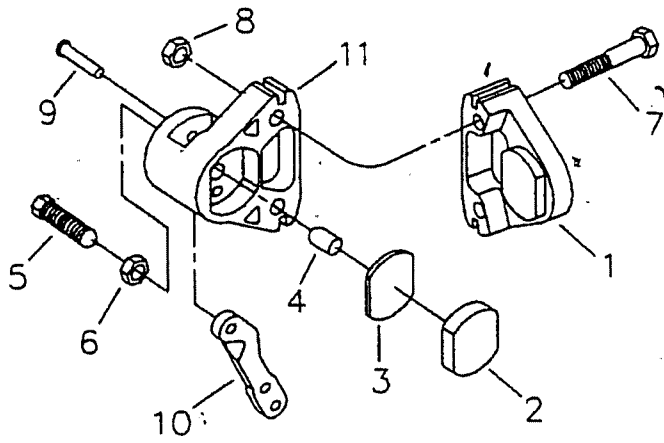

REF	PART #	DESCRIPTION
ASM	9598	BRAKE CALIPER ASSEMBLY (INCL. 1-11)
ASM	9810	BRAKE PAD SERVICE KIT (INCL. 1-3)
1	—	ANVIL WITH LINING
2	—	BRAKE LINING
3	3928	BACKING PLATE
4	3930	ACTUATOR PIN
5	3931	ADJUSTOR PIN
6	3932	NUT, JAM
7	9158	BOLT, 3/8-16 X 2-1/4"
8	9085	NUT, 3/8-16 TOPLOCK HEX
ASM	6534	MB-1 SERVICE KIT (INCL. 9-11)
9	—	GROOVE PIN
10	—	LEVER
11	—	BRAKE HOUSING

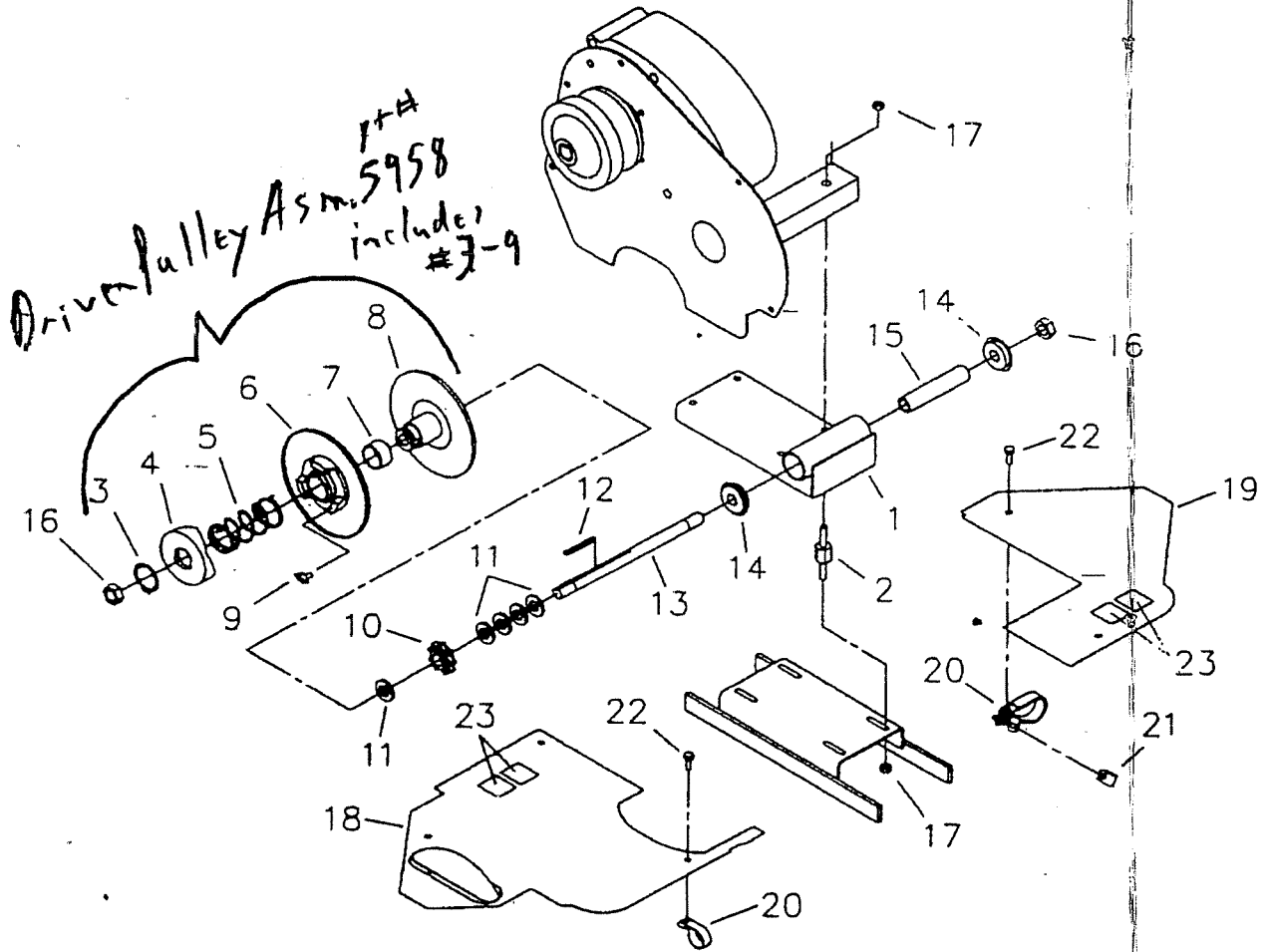

REF	PART #	DESCRIPTION
1	1110-2	CHASSIS WELDMENT, BLACK
2	1356	STUD ASSEMBLY
3	2477	RETAINING RING
4	—	CAM
5	6805	SPRING
6	—	MOVEABLE SHEAVE
7	—	BUSHING
8	—	STATIONARY SHEAVE
9	6804	BUTTON, NYLON
10	8720	SPROCKET, 9-TEETH INT. KEY
11	1119	SPACER, 5/8" I.D. X 1/8"
12	3403	KEY, 3/16" SQ. X 2"

REF	PART #	DESCRIPTION
13	1118	JACKSHAFT, 5/8" X 10.00
14	5090	BEARING, 5/8" I.D.
15	1116	SPANNER, 5/8" I.D. X 4-13/16"
16	1136	NUT, 5/8-18 CENTERLOCK HEX JAM
17	1263	NUT, 5/16-18 FLANGED WHIZ
18	8241	LEFT DECK COVER ASSEMBLY
19	8230	RIGHT DECK COVER
20	8266	LOOP CLIP
21	8227	NUT, 1/4-20 TINNERMAN
22	1876	BOLT, 1/4-20 X 5/8" HEX FLANGED WHIZ
23	11330	DECAL SHEET, ENGINE AND MAIN FRAME WARNINGS