

Operator's Manual
SUPPLEMENT
Model No. 485B-2

▲WARNING:

Read Engine Owner's Manual, Vehicle Operator's Manual, and Supplement Carefully Before Operating Vehicle.

Parts List



ORDERING PARTS

FAST & EASY!

- 1) Seek Part(s) from your models illustrated diagram, cross over REF# to PART#
- 2) Type PART# into sites [Search Box] at GoKartsRus.com TIP! - RIGHT CLICK LINK, SELECT OPEN IN NEW TAB
- 3) Add all needed parts to Shopping Cart | Complete "Checkout" | ✓ Done!

If a part does not come up in a Site Search, please [Contact Us](#) (include part# in email)

LOWEST PRICE!

**THIS VEHICLE IS FOR
OFF-ROAD USE ONLY**

BEFORE OPERATING THIS VEHICLE, THE OWNER AND/OR OPERATOR MUST UNDERSTAND THE VEHICLE WAS NOT DESIGNED OR MANUFACTURED TO MEET SPECIFICATIONS FOR USE ON STREETS, HIGHWAYS, OR THOROUGHFARES AND HAVE READ AND HAVE AN UNDERSTANDING OF ALL THE INSTRUCTIONS FOR SAFE ASSEMBLY AND OPERATION AS WELL AS THE INSTRUCTIONS GOVERNING THE ENGINE AND OTHER PORTIONS OF THE VEHICLE.

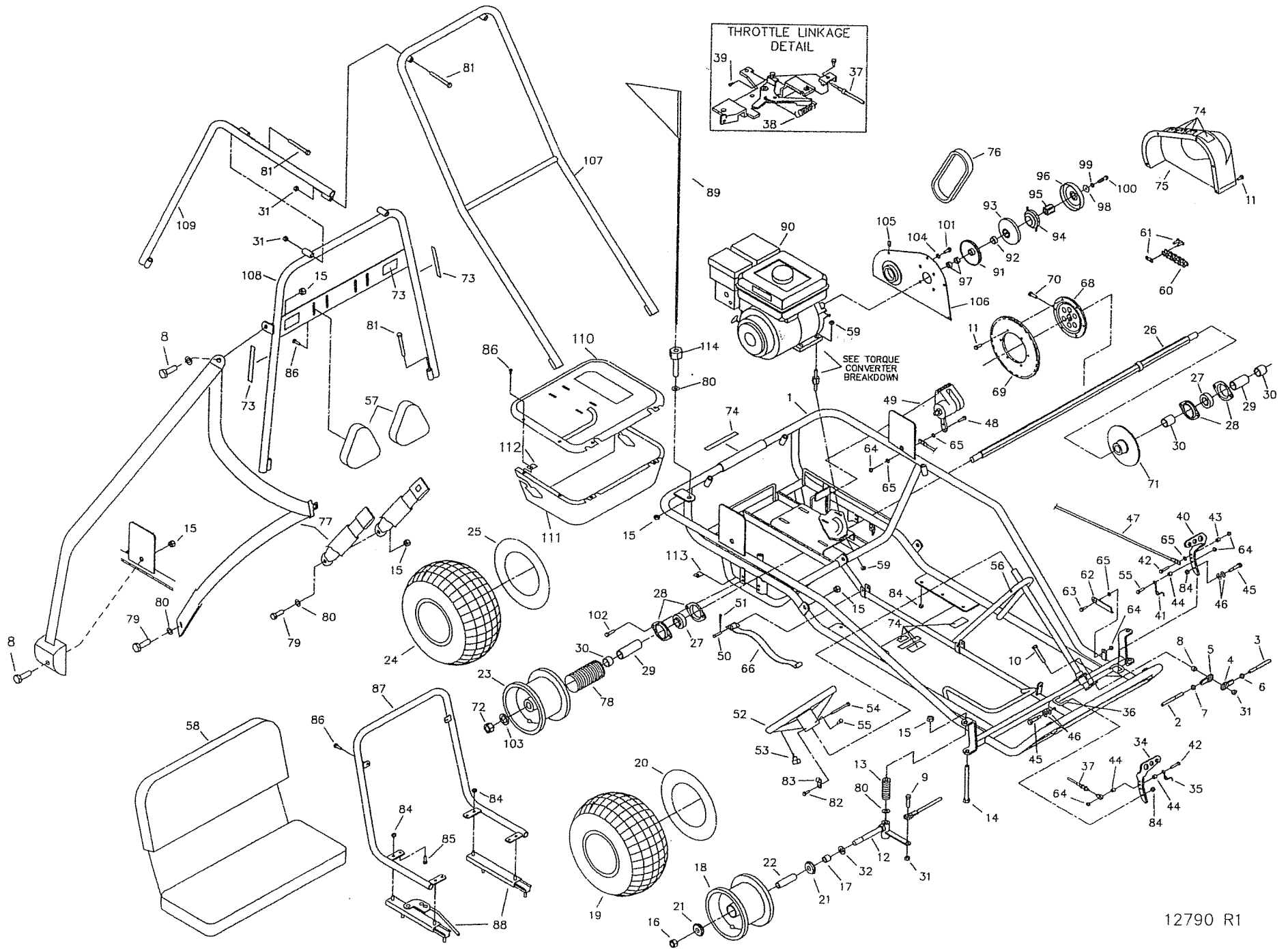

PARTS LIST MODEL 485B-2

REF	PN	DESCRIPTION	REF	PN	DESCRIPTION	REF	PN	DESCRIPTION
1	12261-38	FRAME WELDMENT, ROYAL BLUE	45	1447	BOLT, 3/8 X 1-1/8 SHOULDER	ASM	5957	DRIVER PULLEY ASM (INCL. 91-96)
ASM	10869	TIE ROD ASM LONG (INCL. 2, 4-7)	46	9091	WASHER, FLAT 3/8 SAE N	91	----	STATIONARY SHEAVE
ASM	5020	TIE ROD ASM SHORT (INCL. 3-7)	47	12318-2	BRAKE ROD BLACK	92	200349	BUSHING
2	10868	TIE ROD 19.0	48	1847	BOLT, 1/4-20 X 1"	93	----	MOVEABLE SHEAVE
3	5004	TIE ROD 7.25	49	9597	BRAKE CALIPER ASSEMBLY	94	----	SHOE ASSEMBLY
4	1415	TIE ROD END LH THREAD	50	9118	PIN, CLEVIS 1/4 X 1.250 Z	95	----	HUB
5	1414	TIE ROD END RH THREAD	51	9116	PIN, COTTER 3/32 X .750 Z	96	----	DRUM
6	9024	NUT, 3/8-24 JAM LH THREAD	52	6038	STEERING WHEEL	97	1938	SPACER, 3/4" I.D. X 3/8" LONG
7	9092	NUT, 3/8-24 JAM RH THREAD	53	9799	STOP SWITCH WIRE ASM	98	1398	WASHER, 21/64 ID X 1 1/4 X 1/8
8	9674-16	SPACER, 3/8 ID X 3/8 LONG	NI	12273	WIRE HARNESS	99	1124	WASHER, 5/16" SPLITLOCK
9	9146	BOLT, 3/8-16 X 1.50	54	9080	BOLT, 1/4-20 X 2.750	100	8204	BOLT, 5/16-24 X 2-1/4"
10	9158	BOLT, 3/8-16 X 2.25	55	9160	BOLT, 1/4-20 X .875	101	9101	BOLT, 5/16-24 X .500 W/ NYLOK
11	9006	BOLT, 1/4-20 X .50 HEX FLANGED WHIZ	56	9796	BOLT, #12-24 X .500 SELF TAPPING	102	2264	BOLT, 5/16-18 X 3/4" LONG
NI	10548-2Z	SPINDLE WELDMENT LEFT BLACK	57	6320	HEADREST PAD	103	1194	WASHER, 3/4" SAE FLAT
12	10549-2Z	SPINDLE WELDMENT RIGHT BLACK	58	11359	SEAT BACK/BOTTOM	104	9060	WASHER, 5/16 FLAT
13	9709	COMPRESSION SPRING	59	1263	NUT 5/16-18 HEX FLANGED WHIZ	105	8227	NUT, 1/4-20 TINNERMAN
14	5682	BOLT, 1/2-13 X 5.500	60	6511	CHAIN 420 X 66 ML	106	11775-2	PLATE COVER GBLK
15	1012	NUT, 1/2-13 TOPLOCK	61	2037	MASTERLINK 420 CHAIN	NI	8231	COVER PLATE EXTENSION
16	1046	NUT, 5/8-11 TOPLOCK	62	1982-2	PEDAL LATCH, BLACK	NI	8258	RIVET AL/AL .25GRIP .125DIA
17	1104	SPACER SPLIT .812OD .625ID 1.000L	63	1846	BOLT, 1/4-20 X .750	107	10537-2	OVERHEAD BAR WELDMENT BLACK
18	12490	WHL ASSY STL 6" FREE 5/8 BRGS 145/70 KN	64	9057	NUT, 1/4-20 TOPLOCK	108	10544-2	CENTER BAR WELDMENT BLACK
19	4915C	TIRE 145/70 X 6" KNOBBY	65	1854	WASHER, #14 FLAT MS Z	109	10541-2	REAR BAR WELDMENT BLACK
20	3802	INNER TUBE 6" (REPAIR PART ONLY)	66	4372	HANDHOLD STRAP	110	12287	COVER TOP 48X
21	5090	BEARING, 5/8" I.D.	68	6280H	SPROCKET HUB HEX	111	12288	COVER BOTTOM 48X
22	5950	SPANNER, 5/8" I.D. X 2-1/8"	69	9338	SPROCKET, 420 X 60 TEETH	112	11824	NUT TINNERMAN 2372-04
23	10381	WH ASM 8IN STL HEXWH 18X950 KN	70	6701	BOLT 5/16-18 X 1.250 SHCS	113	2449	NUT TINNERMAN C7343-1420-4
24	3548K	TIRE 18/9.5 X 8 - KENDA	71	9511H	BRAKE DISK	114	11361	BOLT - FLAG MOUNTING
25	1430	TUBE 18/9.5 X 8 (REPAIR ONLY)	72	9162	NUT, 3/4" TOPLOCK HEX	NI	1019	CABLE TIE
26	12359	AXLE WLDMT 486C/485B-2	73	11329	DECAL SHEET, CENTER BAR WARNINGS	NI	8746M	SAFETY VIDEO
27	3941H	BEARING, SEALED 7/8" HEX	74	11330	DECAL SHEET, ENGINE AND MAIN FRAME WARNINGS	NI	11863	OPERATOR'S MANUAL
28	1760	BEARING FLANGE	75	11776	TAV COVER 2XX4XX			
29	4662-16	SPACER 1.000ID 4.250L	76	5959	DRIVE BELT			
30	5222-16	SPACER 1" ID X 1.250L - ZINC	77	8778	LAP SHOULDER SEAT BELT			
31	9085	NUT, 3/8-16 TOPLOCK HEX	78	G0631	LOOM 6.312 L 1.625 ID			
32	1119	SPACER .625ID 1.062OD .125THK Z	79	9188	BOLT, 1/2-13 X 1.50			
34	6309-16	PEDAL, THROTTLE TRIMMED	80	9022	WASHER, 1/2 FLAT			
35	9503	SPRING, PEDAL RIGHT WOUND	81	2386	BOLT, 3/8-16 X 3.50			
36	9929	RUBBER CAP .25ID X .25 BLACK	82	5287	BOLT #10-16 X .375 SELF TAPPING			
37	8251	THROTTLE CABLE 74.50 INCH	83	5288	WIRE CLAMP			
38	12347	SWIVEL SCREW	84	1189	NUT, 5/16-18 HEX TOPLOCK			
39	12348	RETURN SPRING	85	9189	BOLT, 1/4-20 X .875 WHIZ FLANGE			
40	6293-16	PEDAL, BRAKE TRIMMED	86	1876	BOLT 1/4-20 X .625 WHIZ FLANGE			
41	9502	SPRING, PEDAL LEFT WOUND	87	9968-2	SEAT FRAME WELDMENT BLACK			
42	1848	BOLT, 1/4-20 X 1.25"	88	6734	SEAT SLIDE PR - SHORT			
43	6349	BUSHING, 5/16 OD X 22G	89	5447	SAFETY FLAG - 6FT			
44	1389	BUSHING, 1/4 ID X .313	90	12247	ENGINE ROBIN 5HP OHC			

ASM = ASSEMBLY
NI = NOT ILLUSTRATED

TORQUE CONVERTER
BREAKDOWN

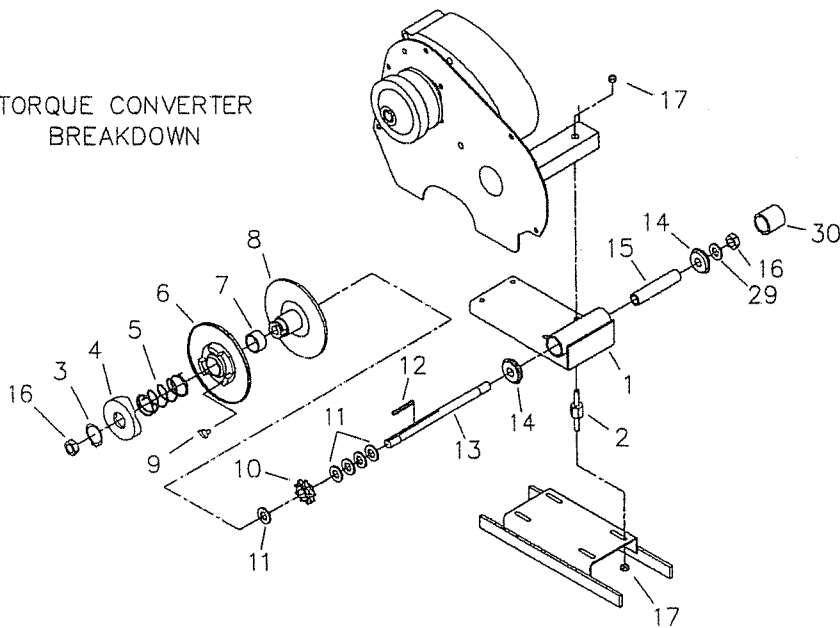

CALIPER BREAKDOWN

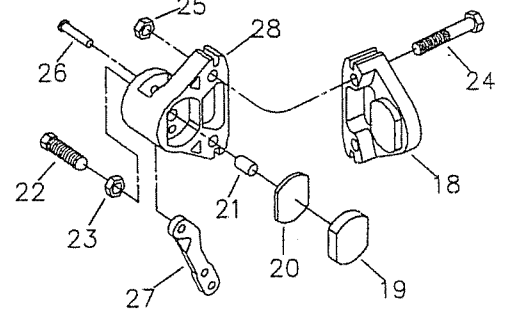

REF	PART #	DESCRIPTION
1	11806-2	CHASSIS WELDMENT, BLACK
2	1356	STUD ASSEMBLY
ASM	5958	DRIVEN PULLEY 30S 217610 (INCL. 3-9)
3	2477	RETAINING RING
4	-----	CAM
5	6805	SPRING
6	-----	MOVEABLE SHEAVE
7	-----	BUSHING
8	-----	STATIONARY SHEAVE
9	6804	BUTTON, NYLON
10	8720	SPROCKET, 9-TEETH INT. KEY
11	1119	SPACER, 5/8" I.D. X 1/8"
12	3403	KEY, 3/16" SQ. X 2"
13	2777	JACKSHAFT, 5/8" X 10.00
14	5090	BEARING, 5/8" I.D.
15	10342	SPANNER, 5/8" I.D. X 4-13/16"
16	1136	NUT, 5/8-18 CENTERLOCK HEX JAM
17	1263	NUT, 5/16-18 FLANGED WHIZ
ASM	9597	BRAKE CALIPER ASSEMBLY
ASM	9810	BRAKE PAD SERVICE KIT
18	-----	ANVIL WITH LINING
19	-----	BRAKE LINING
20	3928	BACKING PLATE
21	3930	ACTUATOR PIN
22	3931	ADJUSTOR PIN
23	3932	NUT, JAM
24	9158	BOLT, 3/8-16 X 2-1/4"
25	9058	NUT, 3/8-16 TOPLOCK HEX
ASM	6534	MB-1 SEVRVCE KIT
26	-----	GROOVE PIN
27	-----	LEVER
28	-----	BRAKE HOUSING
29	1469	WASHER .625ID 1.062OD .062 THK Z
30	11808	VINYL CAP