

Operator's Manual SUPPLEMENT

MANCO MODELS NOS.

485

445



Models shown are deluxe versions.

ORDERING PARTS

- FAST & EASY!**
- 1) Seek Part(s) from your models illustrated diagram, cross over REF# to PART#
 - 2) Type PART# into sites [Search Box] at GoKartsRus.com TIP! - RIGHT CLICK LINK, SELECT OPEN IN NEW TAB
 - 3) Add all needed parts to Shopping Cart | Complete "Checkout" | Done!

If a part does not come up in a Site Search, please [Contact Us](#) (include part# in email)

LOWEST PRICES!

REPAIR PARTS

Models 445-03/04 & 485-03/04

NOTE: This repair parts list supplies part numbers for models 445-03/04 and 485-03/04. Most components are the same for all models. However, descriptions followed by a model number signify that part is only used on the models listed.

REF. NO.	PART NO.	DESCRIPTION	REF. NO.	PART NO.	DESCRIPTION
1	4884-2	Frame (485-03/04)	59	4925	Wheel Half 6" Steel (w/Valve) (445-03 & 485-03)
1	6273-2	Frame (445-03/04)	59	4925-2	Wheel Half 6" Steel-Black (w/Valve) (445-04 & 485-04)
2	6010	Engine 5 HP			
3	6529-2	Rear Bar RT (485-03/04)	60	4926	Wheel Half 6" Steel (w/o Valve) (445-03 & 485-03)
3	6537-2	Rear Bar RT (445-03/04)	60	4926-2	Wheel Half 6" Steel-Black (w/o Valve) (445-04 & 485-04)
4	6530-2	Rear Bar LT (485-03/04)			
4	6544-2	Rear Bar LT (445-03/04)	61	2388	3/8-24 Hex Nut
5	1189	3/16-18 Hex Lock Nut	62	1130	3/8 Split Lock Washer
6	2264	3/16-18 x 3/4 Hex Cap Screw	63	3801S	Tire 15 x 6 — 6 Turf Saver
7	6532-2	Center Bar (485-03/04)	64	3802	Inner Tube 6" JS87N Stem
7	6325-2	Center Bar (445-03/04)	65	4927	6" Live Axle Hub
8	6217	Headrest Double (485-03)	66	1264	1/2-13 x 3 1/2 Hex Cap Screw
8	6580	Deluxe Headrest Dbl. (485-04)	67	1012	1/2-13 Hex Toplock Nut
8	6320	Headrest Single (445-03)	68	8020	Spindle
8	6585	Deluxe Headrest Sgl. (445-04)	69	1937	Spacer, 3/8 ID x 1/4 Lg.
9	4327	Seat Bottom/Flap (485-03)	70	1093	Bearing
	4328	Seat Back (485-03)	71	1186	1/4-20 Hex Whizlock Nut
9	6579	Deluxe Dbl. Seat (485-04)	72	8004	Wheel Half-5" (445-03 & 485-03)
9	4324	Single Seat (445-03)	72	8004-2	Wheel Half-5"-Black (445-04 & 485-04)
9	6584	Deluxe Sgl. Seat (445-03)	73	1753	Inner Tube, 4.10-3.50 x 5 (Front)
10	3325-2	Seat Frame (485-03)	74	2246	Tire, 4.10-3.50 x 5 (Front)
10	6586-2	Seat Frame (485-04)	75	5839	1/4-20 x 3/4 Hex Flanged Whiz
10	3347-2	Seat Frame (445-03)	76	5949	Spanner 3/8 ID x 1 1/16 (Wh. Asm.)
12	1496	Throttle Cable (485-03/04)	77	1046	3/8-11 Hex Lock Nut
12	1390	Throttle Cable (445-03/04)	78	1263	3/8-18 Hex Fl. Whizlock Nut
13	6232	Rubber Washer	79	1194	3/4 SAE Flat Washer
14	1760	Bearing Flange	80	4341	Pan Decal (485-03)
15	1876	1/4-20 x 3/8 Hex Fl. Whizlock Screw	80	6595	Pan Decal (485-04)
16	2998	Sprocket 35A72	80	4342	Pan Decal (445-03)
17	6280	Sprocket Hub	80	6596	Pan Decal (445-04)
18	6701	3/16-18 x 1 SHCS	81	1775	Key - 1/4 x 1/4 x 1 1/4
19	1324	Chain-#35 x 78 Pitch w/Masterlink	82	6126	Arm Pad (485-03 & 445-03)
20	3941	Bearing 1.0 ID	82	6581	Arm Pad Covers (485-04 & 445-04)
21	2264	3/16-18 x 3/4 Hex Cap Screw		6582	Arm Pad (485-04 & 445-04)
23	4914	Spacer, 1.0 ID x 3/8 Lg.	83	9146	3/8-16 x 1 1/2 Hex Cap Screw
24	1078	Brake Drum	84	1494	Mounting Bracket
25	5646	Spacer, 1.0 ID x 2 1/4 Lg.	85	9030	3/16 Internal Lock Washer
26	9118	1/4 Dia. x 1 1/4 Lg. Clevis Pin	86	9101	3/8-24 x 1/2 Nylock Hex Cap Screw
27	1854	1/4 Std. Flat Washer	87	1463	Insulating Bushing
28	1492	Brake Band	88	1356	Stud Assembly
29	9116	3/2 Dia. x 3/4 Lg. Cotter Pin	89	1387	Axle Shaft (485-03/04)
30	4944-2	Brake Rod Rear	89	6274	Axle Shaft (445-03/04)
31	5681	Compression Spring	91	1393	Ring Terminal
32	2377	Brake Rod Front	92	1394	Stop Switch Wire
33	1392	Stop Switch	93	1406	Wiring Harness
34	6038	Steering Wheel	94	9006	1/4-20 x 1/2 Hex Flanged Whiz
35	9080	1/4-20 x 2 3/4 Hex Cap Screw	NI	1628	Cable Retainer (See Back)
36	9160	1/4-20 x 1/8 Hex Cap Screw w/Nylock	NI	8021	Spindle
37	9057	1/4-20 Hex Toplock Nut	NI	4372	Hand Hold (485-03/04)
38	1982	Pedal Latch	NI	6594	Torque Converter Cover Decal (445-04)
39	1082	Spacer, 1.0 ID x 1/8 Lg.	NI	6593	Torque Converter Cover Decal (485-04)
40	4913	Spacer, 1.0 ID x 3 (485-03/04)	NI	3296	MPI Steering Wheel Decal (445-03 & 485-03)
40	1448	Spacer, 1.0 ID x 3 3/8 (445-03/04)	NI	6592	Custom Steering Wheel Decal (445-04 & 485-04)
41	1845	1/4-20 x 3/8 Hex Cap Screw	NI	6626	Tire Pressure Decal
42	1848	1/4-20 x 1 1/4 Hex Cap Screw	ASM	4930	Wheel Asm., 5" Knobby (Inc. Ref. #70-76) (445-03 & 485-03)
43	1019	Tywrap			
44	9052	3/4-16 Hex Toplock Nut	ASM	4930B	Wheel Asm. -Black, 5" Knobby (Inc. Ref. #70-76) (445-04 & 485-04)
45	8009	Brake Pedal			
46	6123	Key, 1/4 x 1/4 x 1 3/4	ASM	4924P	Wheel Asm., 6" Turf Saver (Inc. Ref. #59-65) (445-03 & 485-03)
47	9091	3/8 Std. Flat Washer			
48	1389	Bushing	ASM	4924B	Wheel Asm. -Black, 6" Turf Saver (Inc. Ref. #59-65) (445-04 & 485-04)
49	9110	3/8 Shoulder Bolt			
50	5003	Tie Rod (Long) (485-03/04)	ASM	4358	Tie Rod LH (Short) (Inc. Ref. #50-54) (485-03/04)
50	4356	Tie Rod (485-03/04)	ASM	4359	Tie Rod RH (Long) (Inc. Ref. #50-54) (485-03/04)
50	4352	Tie Rod (Qty. 2) (445-03/04)	ASM	4355	Tie Rod (Inc. Ref. #50-54) (445-03/04)
51	9092	3/8-24 RH Hex Jam Nut	ASM	2999	Sprocket Assembly (Inc. Ref. #16-18 & 94)
52	1414	Rod End, RH			
53	1415	Rod End, LH			
54	9024	3/8-24 LH Hex Jam Nut			
55	9158	3/8-16 x 2 1/4 Hex Cap Screw			
56	9085	3/8-16 Toplock Hex Nut			
57	1846	1/4-20 x 3/4 Hex Cap Screw			
58	8011	Throttle Pedal			

NI = NOT ILLUSTRATED
ASM = COMPLETE ASSEMBLY

REPAIR PARTS

TORQUE CONVERTER DRIVE

MODEL 485
445

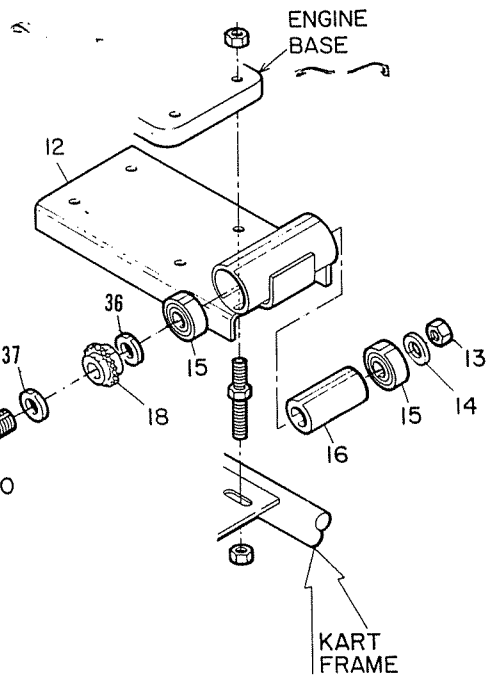
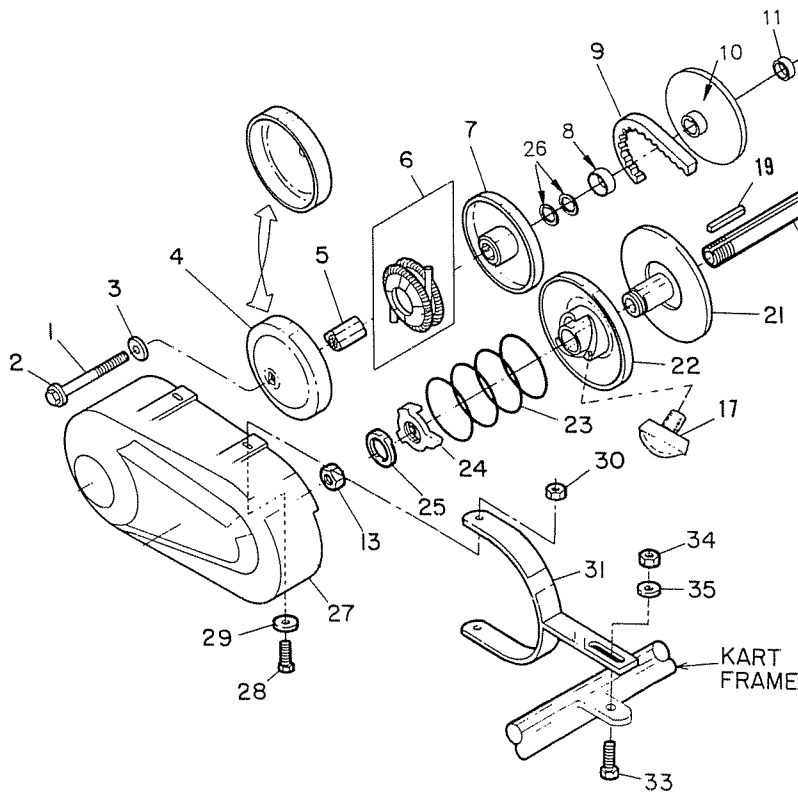

REF. NO.	PART NO.	DESCRIPTION
1	1454	5/16-24 x 1 1/4 Hex Cap Screw
2	1124	5/16 Lockwasher
3	1398	2 1/8 Flat Washer
4		Driver drum
5		Driver hub
6		Driver shoe asm.
7		Moveable sheave - driver
8	200349	Bushing
9	5959	Belt
10		Stationary sheave - driver
11	1938	Spacer
12	1110	Chassis
13	1136	5/8-18 UTA Locknut
14	1469	5/8 I.D. Spacer/washer
15	5090	Bearing
16	1116	Bearing spanner
17	6804	Nylon button - cam - heavy duty
18	3504	Sprocket - 12 tooth - 3/8" pitch
19	3403	1/8 square x 2
20	1118	Jackshaft
21		Stationary sheave
22		Moveable sheave with cam
23	6805	Spring
24		Cam
25	2477	Retaining ring
26	200-836	Washer
27	1542	Cover
28	2277	#8-32 x 1/2 Hex head screw
29	2279	#8 Flat washer
30	2278	#8-32 UTA Locknut
31	1537-2	Mounting bracket
33	1846	1/4-20 x 3/4 Hex head screw Gr 5
34	9057	1/4-20 UTA Locknut
35	1854	1/4 Flat washer
36	1937	5/8 I.D. x 7/8 O.D. x 1/4 Spacer
37	1119	5/8 I.D. x 7/8 O.D. x 1/8 Spacer
ASM	5957	Driving pulley asm. (assembled to crankshaft)
ASM	5958	Driven pulley asm. (assembled to jackshaft)

THROTTLE CABLE INSTALLATION

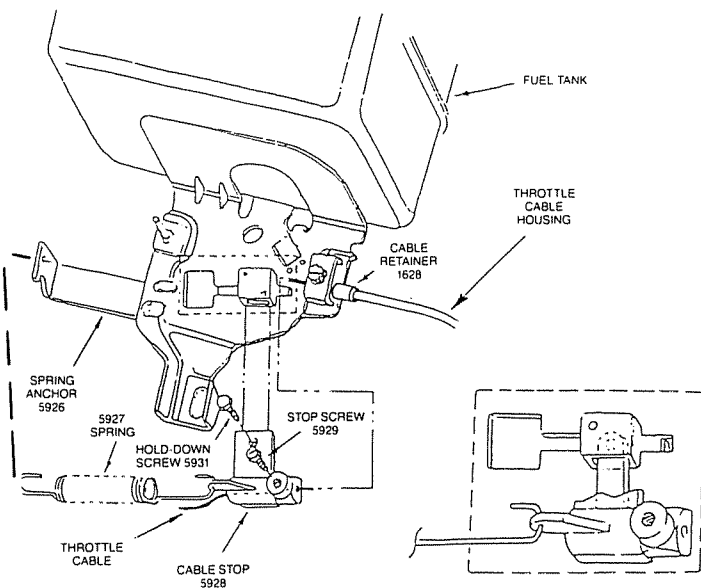

ASSEMBLY: Pass the throttle cable through the cable retainer and butt the throttle cable housing end against the inside shoulder of the cable retainer. (The cable retainer is to be securely fastened to the engine with the clamping screw.) Pass the end of the Throttle Cable through the hole in the cable stop. Before tightening cable stop screw:

1. Ensure spring anchor, spring, and cable are installed as illustrated above.
2. Ensure throttle pedal is in rearward (idle) position.
3. Ensure that there is no slack in the throttle cable with *no* tension applied to return spring.
4. Ensure cable housing is inside and against the cable retainer.