

Operator's Manual
SUPPLEMENT
Model No. 495B

⚠ WARNING:

Read Engine Owner's Manual, Vehicle Operator's Manual, and Supplement Carefully Before Operating Vehicle.

Parts List



ORDERING PARTS

FAST & EASY!

- 1) Seek Part(s) from your models illustrated diagram, cross over REF# to PART#
- 2) Type PART# into sites [Search Box] at GoKartsRus.com TIP! - RIGHT CLICK LINK, SELECT OPEN IN NEW TAB
- 3) Add all needed parts to Shopping Cart | Complete "Checkout" | ✓ Done!

If a part does not come up in a Site Search, please [Contact Us](#) (include part# in email)

LOWEST PRICES!

**THIS VEHICLE IS FOR
OFF-ROAD USE ONLY**

BEFORE OPERATING THIS VEHICLE, THE OWNER AND/OR OPERATOR MUST UNDERSTAND THE VEHICLE WAS NOT DESIGNED OR MANUFACTURED TO MEET SPECIFICATIONS FOR USE ON STREETS, HIGHWAYS, OR THOROUGHFARES AND HAVE READ AND HAVE AN UNDERSTANDING OF ALL THE INSTRUCTIONS FOR SAFE ASSEMBLY AND OPERATION AS WELL AS THE INSTRUCTIONS GOVERNING THE ENGINE AND OTHER PORTIONS OF THE VEHICLE.

PARTS LIST MODEL 495B

REF	PN	DESCRIPTION
1	13101-13	FRAME WELDMENT, ORANGE
ASM	10869	TIE ROD ASM LONG (INCL. 2, 4-7)
ASM	5020	TIE ROD ASM SHORT (INCL. 3-7)
2	10868	TIE ROD 19.0
3	5004	TIE ROD 7.25
4	1415	TIE ROD END LH THREAD
5	1414	TIE ROD END RH THREAD
6	9024	NUT, 3/8-24 JAM LH THREAD
7	9092	NUT, 3/8-24 JAM RH THREAD
8	9674-16	SPACER, 3/8 ID X 3/8 LONG
9	9146	BOLT, 3/8-16 X 1.50
10	9158	BOLT, 3/8-16 X 2.25
11	9006	BOLT, 1/4-20 X .50 HEX FLANGED WHIZ
NI	10548-2Z	SPINDLE WELDMENT LEFT BLACK
12	10549-2Z	SPINDLE WELDMENT RIGHT BLACK
13	9709	COMPRESSION SPRING
14	5682	BOLT, 1/2-13 X 5.500
15	1012	NUT, 1/2-13 TOPLOCK
16	1046	NUT, 5/8-11 TOPLOCK
17	1104	SPACER SPLIT .812OD .625ID 1.000L
18	12490	WHL ASSY STL 6" FREE 5/8 BRGS 145/70 KN (INCL. 19 & 20)
19	4915C	REPLACEMENT TIRE FOR #12490
20	3802	REPLACEMENT TUBE FOR #12490
21	5090	BEARING, 5/8" I.D.
22	5950	SPANNER, 5/8" I.D. X 2-1/8"
23	10381	WH ASM 8IN STL HEXWH 18X950 KN (INCL. 24 & 25)
24	3548K	REPLACEMENT TIRE FOR #10381
25	1430	REPLACEMENT TUBE FOR #10381
26	12359	AXLE WLDMT 486C/485B-2
27	3941H	BEARING, SEALED 7/8" HEX
28	1760	BEARING FLANGE
29	4662-16	SPACER 1.000ID 4.250L
30	5222-16	SPACER 1" ID X 1.250L - ZINC
31	9085	NUT, 3/8-16 TOPLOCK HEX
32	1119	SPACER .625ID 1.062OD .125THK Z
34	6309-16	THROTTLE PEDAL
35	9503	PEDAL SPRING - RIGHT WOUND
36	9929	RUBBER CAP .25ID X .25 BLACK
37	8251	THROTTLE CABLE 74.50 INCH
38	12347	SWIVEL SCREW
39	12348	RETURN SPRING
40	6293-16	BRAKE PEDAL
42	1848	BOLT, 1/4-20 X 1.25"

REF	PN	DESCRIPTION
44	1389	BUSHING, 1/4 ID X .313
45	1447	BOLT, 3/8 X 1-1/8 SHOULDER
46	9091	WASHER, FLAT 3/8 SAE N
47	12318-2	BRAKE ROD BLACK
48	1847	BOLT, 1/4-20 X 1"
49	9597	BRAKE CALIPER ASSEMBLY
50	9118	PIN, CLEVIS 1/4 X 1.250 Z
51	9116	PIN, COTTER 3/32 X .750 Z
52	6038	STEERING WHEEL
53	9799	STOP SWITCH WIRE ASSEMBLY
NI	12273	WIRE HARNESS
54	9080	BOLT, 1/4-20 X 2.750
55	9160	BOLT, 1/4-20 X .875
56	9796	BOLT, #12-24 X .500 SELF TAPPING
57	6320	HEADREST PAD
58	12734	SEAT BACK/BOTTOM
59	1263	NUT 5/16-18 HEX FLANGED WHIZ
60	6511	CHAIN 420 X 66 ML
61	2037	MASTERLINK - 420 CHAIN
62	1982-2	PEDAL LATCH - BLACK
63	1846	BOLT, 1/4-20 X .750
64	9057	NUT, 1/4-20 TOPLOCK
65	1854	WASHER, #14 FLAT MS Z
66	4372	HANDHOLD STRAP
68	6280H	SPROCKET HUB HEX
69	9338	SPROCKET, 420 X 60 TEETH
70	6701	BOLT 5/16-18 X 1.250 SHCS
71	9511H	BRAKE DISK
72	9162	NUT, 3/4" TOPLOCK HEX
73	11329	DECAL SHEET, CENTER BAR WARNINGS
74	11330	DECAL SHEET, ENGINE AND MAIN FRAME WARNINGS
75	11776	TAV COVER
76	5959	DRIVE BELT
77	8778	LAP SHOULDER SEAT BELT
78	G0631	LOOM 6.312 L 1.625 ID
79	9188	BOLT, 1/2-13 X 1.50
80	9022	WASHER, 1/2 FLAT
81	2386	BOLT, 3/8-16 X 3.50
82	5287	BOLT #10-16 X .375 SELF TAPPING
83	5288	WIRE CLAMP
84	1189	NUT, 5/16-18 HEX TOPLOCK
85	9189	BOLT, 1/4-20 X .875 WHIZ FLANGE
86	1876	BOLT 1/4-20 X .625 WHIZ FLANGE
87	9968-2	SEAT FRAME WELDMENT BLACK
88	6734	SEAT SLIDE PAIR
89	5447	SAFETY FLAG - 6FT

REF	PN	DESCRIPTION
90	12247	ROBIN ENGINE 5HP OHC
ASM	5957	DRIVER PULLEY ASM (INCL. 91-96)
91	**	STATIONARY SHEAVE
92	200349	BUSHING
93	**	MOVEABLE SHEAVE
94	**	SHOE ASSEMBLY
95	**	HUB
96	**	DRUM
97	1938	SPACER, 3/4" I.D. X 3/8" LONG
98	1398	WASHER, 21/64 ID X 1 1/4 X 1/8
99	1124	WASHER, 5/16" SPLITLOCK
100	8204	BOLT, 5/16-24 X 2-1/4"
101	9101	BOLT, 5/16-24 X .500 W/ NYLOK
102	2264	BOLT, 5/16-18 X 3/4" LONG
103	1194	WASHER, 3/4" SAE FLAT
104	9060	WASHER, 5/16 FLAT
105	8227	NUT, 1/4-20 TINNERMAN
106	13094	COVER PLATE ASSEMBLY - BLACK
107	13140-2	OVERHEAD BAR WELDMENT BLACK
108	13138-2	CENTER BAR WELDMENT BLACK
109	13142-2	REAR BAR WELDMENT BLACK
110	13162	TOP COVER
111	12288	BOTTOM COVER
112	6452	BOLT, 3/8-16 X 5.00
113	2449	NUT TINNERMAN C7343-1420-4
114	11361	BOLT - FLAG MOUNTING
NI	1019	CABLE TIE
NI	12844	SAFETY VIDEO
NI	12834	OWNER/OPERATOR MANUAL

ASM = ASSEMBLY
 NI = NOT ILLUSTRATED
 ** = NOT SOLD SEPERATELY

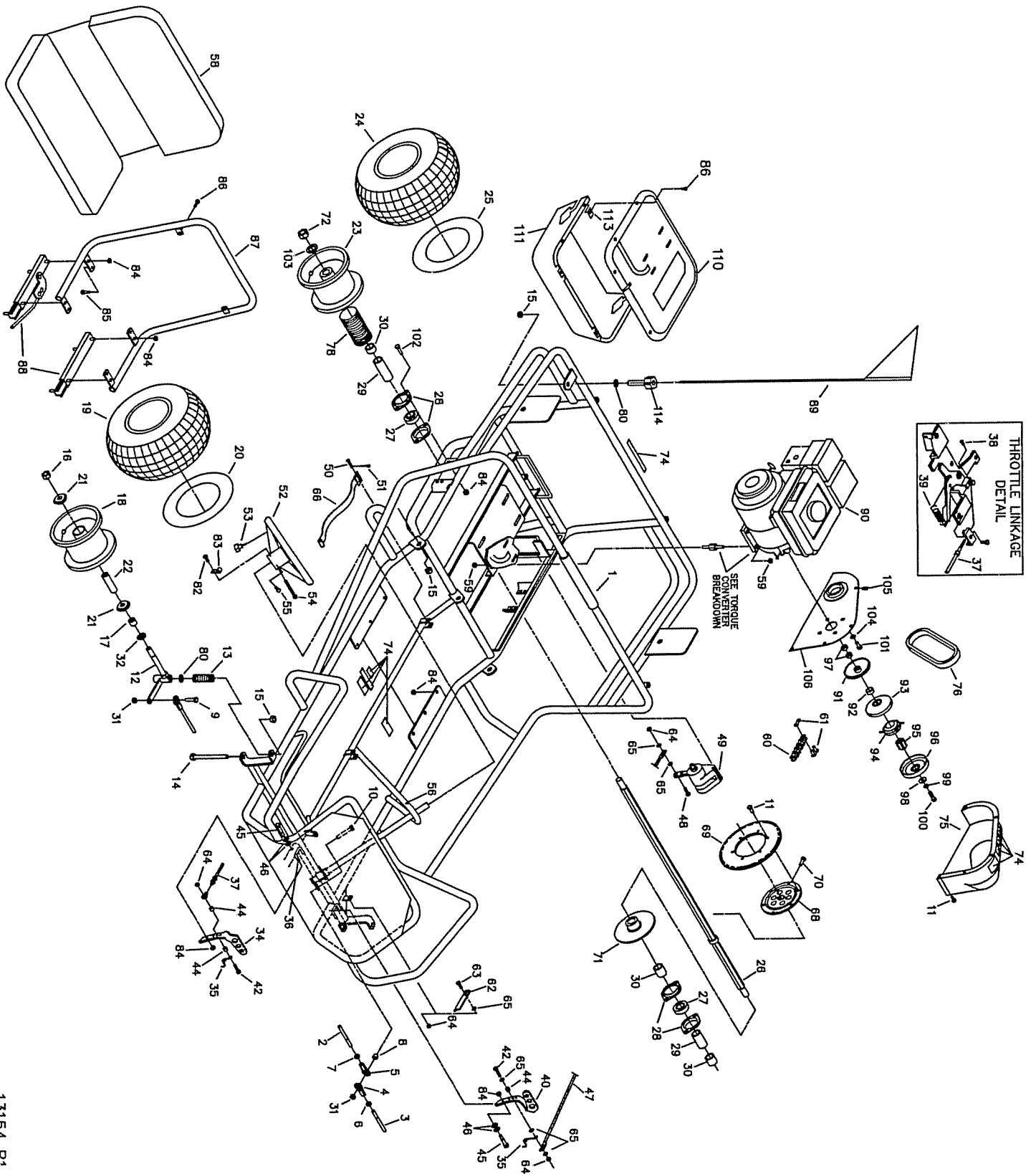

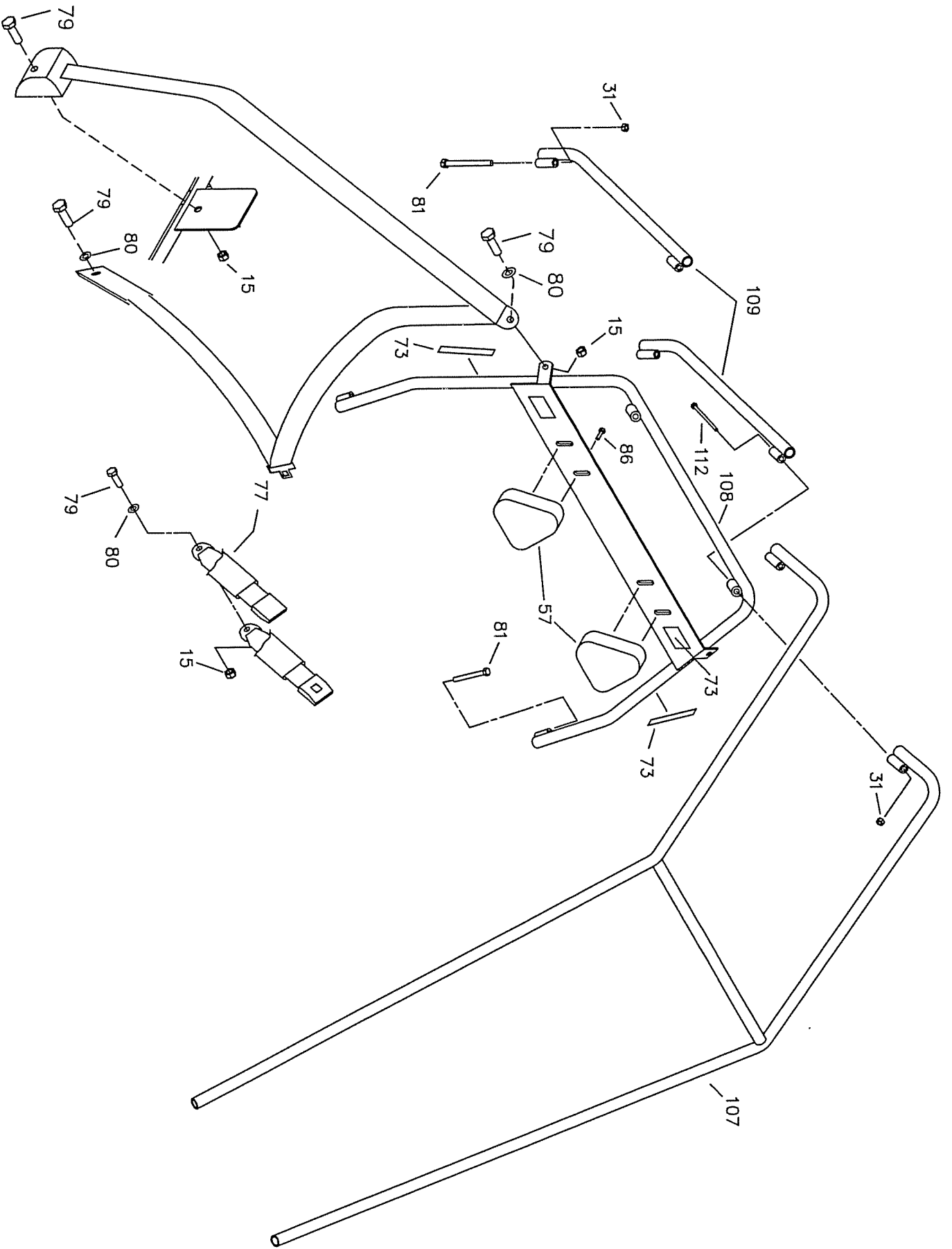

TORQUE CONVERTER
BREAKDOWN

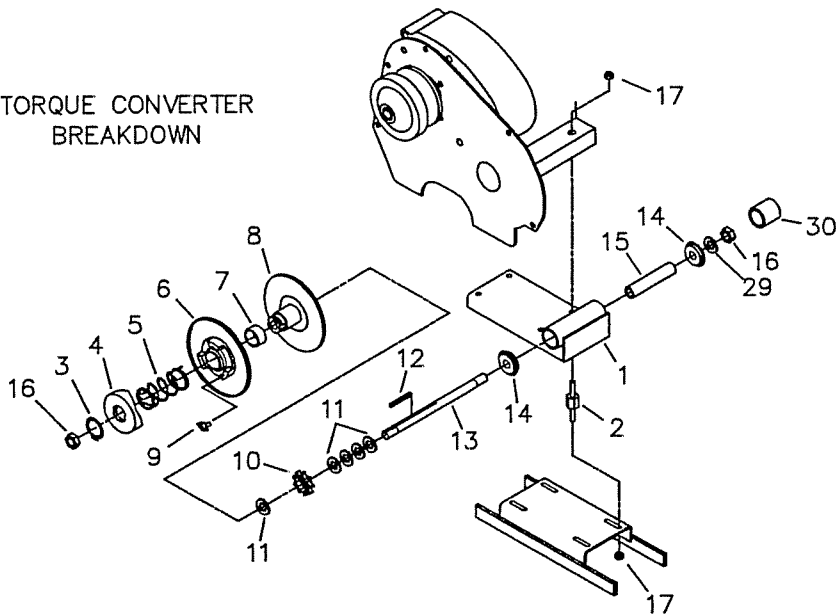

CALIPER BREAKDOWN

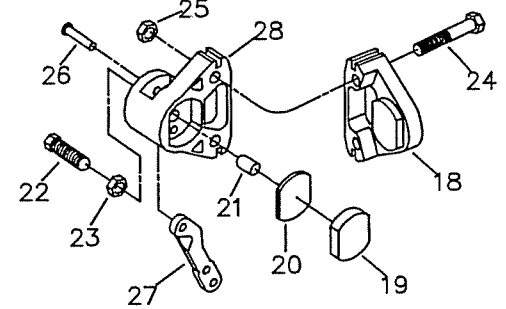

REF	PART #	DESCRIPTION
1	11806-2	CHASSIS WELDMENT, BLACK
2	1356	STUD ASSEMBLY
ASM	5958	DRIVEN PULLEY 30S 217610 (INCL. 3-9)
3	2477	RETAINING RING
4	-----	CAM
5	6805	SPRING
6	-----	MOVEABLE SHEAVE
7	-----	BUSHING
8	-----	STATIONARY SHEAVE
9	6804	BUTTON, NYLON
10	8720	SPROCKET, 9-TEETH INT. KEY
11	1119	SPACER, 5/8" I.D. X 1/8"
12	3403	KEY, 3/16" SQ. X 2"
13	2777	JACKSHAFT, 5/8" X 10.00
14	5090	BEARING, 5/8" I.D.
15	10342	SPANNER, 5/8" I.D. X 4-13/16"
16	1136	NUT, 5/8-18 CENTERLOCK HEX JAM
17	1263	NUT, 5/16-18 FLANGED W HIZ
ASM	9597	BRAKE CALIPER ASSEMBLY
ASM	9810	BRAKE PAD SERVICE KIT
18	-----	ANVIL WITH LINING
19	-----	BRAKE LINING
20	3928	BACKING PLATE
21	3930	ACTUATOR PIN
22	3931	ADJUSTOR PIN
23	3932	NUT, JAM
24	9158	BOLT, 3/8-16 X 2-1/4"
25	9058	NUT, 3/8-16 TOPLOCK HEX
ASM	6534	MB-1 SEVRVICE KIT
26	-----	GROOVE PIN
27	-----	LEVER
28	-----	BRAKE HOUSING
29	1469	WASHER .625ID 1.062OD .062 THK Z
30	11808	VINYL CAP