

Illustrated Parts Manual **6150**

150cc Fun Kart



ORDERING PARTS

FAST & EASY!

- 1) Seek Part(s) from your models illustrated diagram, cross over REF# to PART#
- 2) Type PART# into sites [Search Box] at GoKartsRus.com TIP! - RIGHT CLICK LINK, SELECT OPEN IN NEW TAB
- 3) Add all needed parts to Shopping Cart | Complete "Checkout" | ✓ Done!

If a part does not come up in a Site Search, please [Contact Us](#) (include part# in email)

LOWEST PRICES!

RECOMMENDED MINIMUM OPERATOR AGE: 12

THIS VEHICLE IS FOR OFF-ROAD USE ONLY

THIS VEHICLE IS NOT DESIGNED FOR USE ON RENTAL TRACKS OR RACING

BEFORE OPERATING THIS VEHICLE, THE OWNER AND EACH OPERATOR MUST UNDERSTAND THIS VEHICLE WAS NOT DESIGNED OR MANUFACTURED TO MEET SPECIFICATIONS FOR USE ON PUBLIC ROADS, STREETS, HIGHWAYS, AND THOROUGHFARES. THE OWNER AND EACH OPERATOR MUST READ AND UNDERSTAND ALL THE INSTRUCTIONS FOR PROPER ASSEMBLY AND SAFE OPERATION, AS WELL AS THE INSTRUCTIONS CONCERNING THE ENGINE AND ALL OTHER PORTIONS OF THE VEHICLE. CHILDREN MUST BE OF AGE 12 OR OLDER AND SUPERVISED BY AN ADULT AT ALL TIMES WHEN USING THIS FUN-KART.

Section 1 - Cylinder Head Assembly

Ref. #	Part #	Description	Qty.
1	14254	Head, Cylinder - 150cc	1
2	50304	Plug, Spark - NGK C7HSA	1
3	14255	Gasket, Cylinder Head - 150cc	1
4	14256	Gasket, Carb Insulator - 150cc	1
5	14257	Insulator, Carb - 150cc	1
6	14258	Manifold, Intake - 150cc	1
7	14259	Clamp, Carb Hose - 150cc	1
8	14260	Gasket, Valve Cover - 150cc	1
9	14261	O-Ring, M27x2 Rubber	1
10	14262	Tube, Breather - 150cc	1
11	14263	Stud, M6 x 1.00 x 18	2
12	14264	Stud, M6 x 1.00 x 50	2
13	50003	Bolt, M6 x 1.00 x 25 FHCS	4
14	50024	Nut, M6 x 1.00 Hex Flange	2
15	14265	Cover, Valve - 150cc	1
16	14266	Pin, M10 x 16 Dowel	2
17	50087	Bolt, M6 x 1.00 x 100 FHCS	2
18	14267	Valve, Intake - 150cc	1
19	14268	Seal, Valve Stem - 150cc	2
20	14269	Seat, Valve Spring Outer - 150cc	2
21	14270	Spring, Outer and Inner Valve - 150cc	2
22	14271	Retainer, Valve Spring - 150cc	2
23	14272	Keeper, Valve Spring - 150cc	4
24	14273	Valve, Exhaust - 150cc	1

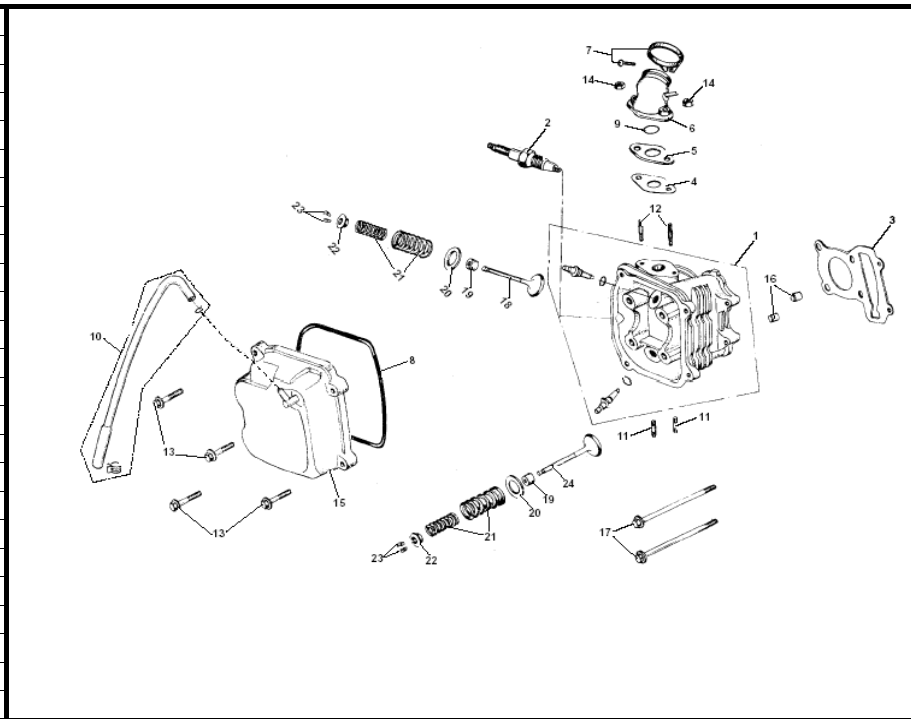

Section 2 - Cylinder

Ref. #	Part #	Description	Qty.
1	14317	Cylinder - 150cc	1
2	14582	Gasket, Cylinder Base - 150cc	1
3	50032	Bolt, M6 x 1.00 x 22 FHCS	2
4	14266	Pin, M10 x 16 Dowel	2
5	14276	Tensioner, Cam Chain - 150cc	1
6	14275	Gasket, Cam Chain Tensioner - 150cc	1
7	14274	Asm, Cam Chain Tensioner - 150cc	1

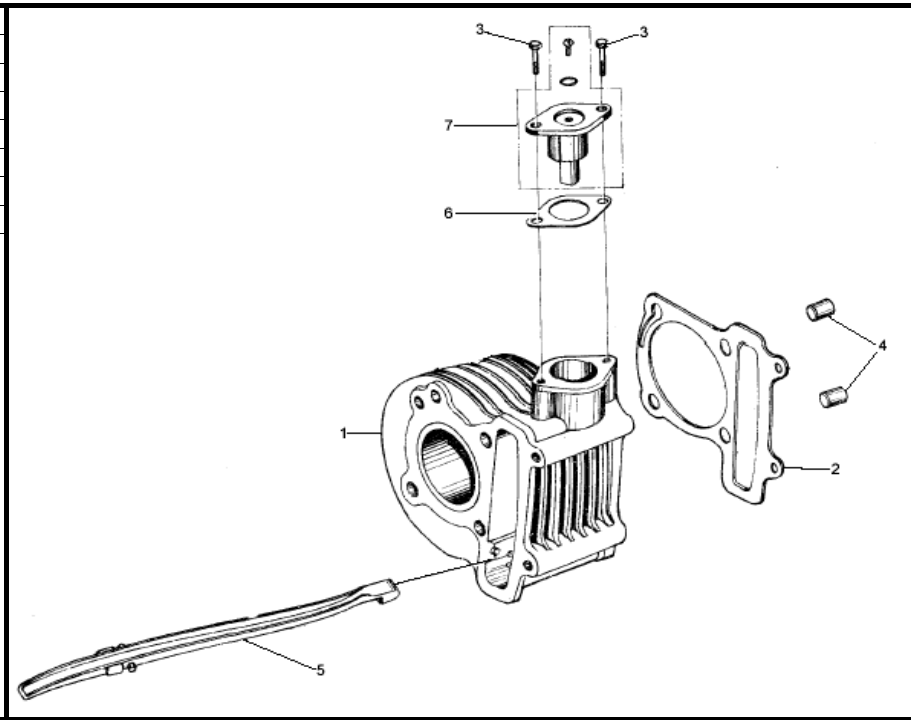

Section 3 - Engine Crankcase

Ref. #	Part #	Description	Qty.
1	14277	Housing, Crankcase RH - 150cc	1
2	14278	Bushing, Engine Hanger - 150cc	2
3	14279	Gasket, Crankcase - 150cc	1
4	14280	Housing, Crankcase LH - 150cc	1
5	14558	Grommet	1
6	14281	Bolt, M10 x 1.25 x 15 FHCS	1
7	14282	Washer, M10.2 x 18 x 1.3 Flat	1
8	14283	Cover, Small Left	1
9	14284	O-Ring, M108 x 2	1
10	14559	Pin	1
11	14285	O-Ring, M6 x 1.8	2
12	50104	Seal, M19.8 x 30 x 5	1
13	14286	Bolt, M6 x 1.00 x 18 FHCS	4
14	14287	Pin, M10 x 14 Dowel	2
15	14288	Bolt, M12 x 1.5 Special	1
16	14289	Washer, M12 Flat	2
17	14290	Seal, M20 x 32 x 6	2
18	14276	Tensioner, Cam Chain - 150cc	1
19	50016	Pin, M8 x 14 Dowel	2
20	14291	Stud, M8 x 1.25 x 195.5	2
21	14292	Stud, M8 x 1.25 x 187.5	2
22	14293	Washer, M8 Flat	4
23	14294	Nut, M8 x 1.25 Flange Head	4
24	14295	Bolt, M6 x 1.00 x 50 FHCS	2
25	14501	Spacer, Oil - 150cc	1
26	14296	Bolt, M6 x 1.00 x 12 FHCS	2

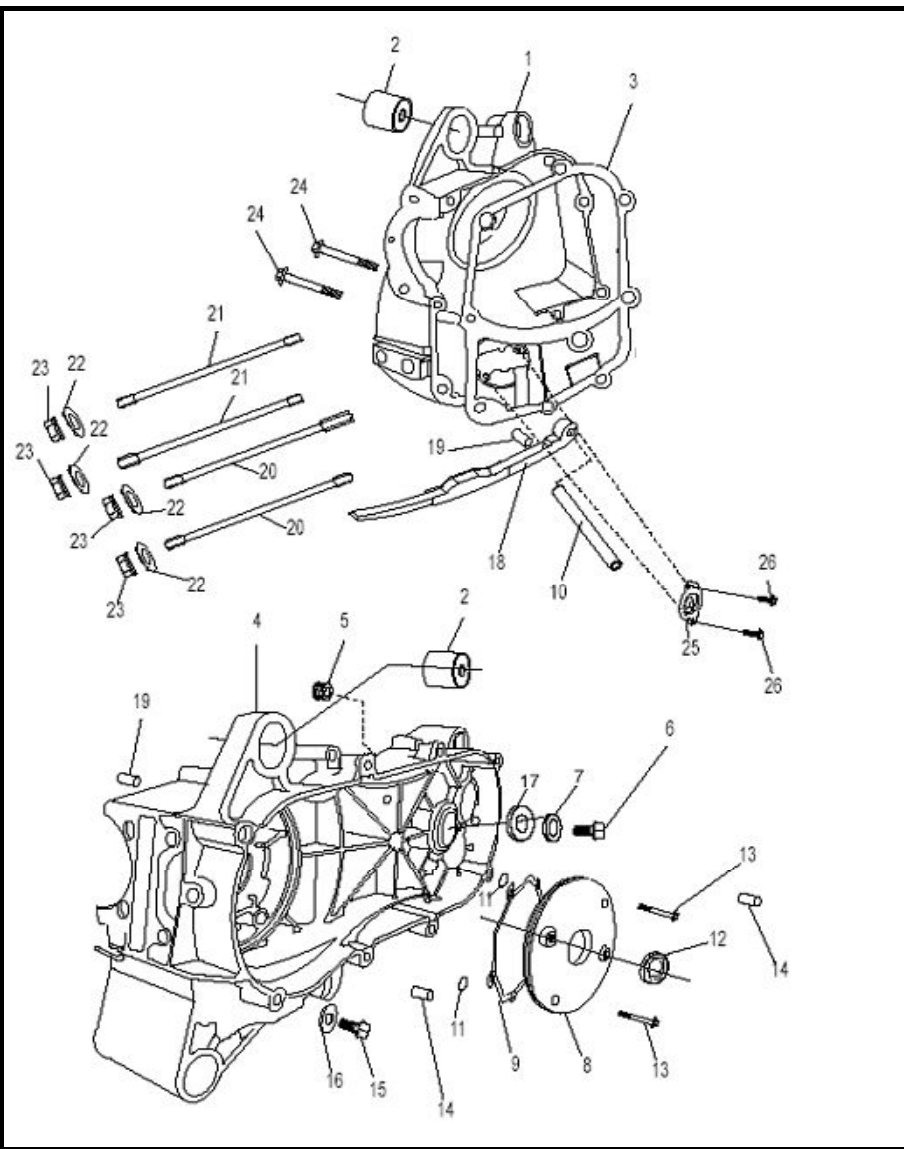

Section 4 - Transmission

Ref. #	Part #	Description	Qty.
1	14297	Housing, Outer Transmission - 150cc	1
2	14298	Gear, Pri Drive - 150cc	1
3	14299	Gear, Sec Drive - 150cc	1
4	14300	Asm, Shift Gear Cluster F/N/R - 150cc	1
5	14301	Gear, Final Drive Shaft	1
6	14302	Asm, Shift Selector - 150cc	1
7	14303	Pawl, Shift Selector - 150cc	1
8	14304	Rod, Shift Pawl - 150cc	1
9	14305	Shaft, Shifter Cam - 150cc	1
10	14306	Gasket, Transmission Case - 150cc	1
11	14307	Tube, Transmission Vent	1
12	14308	Nipple, Vent Tube	1
13	14309	Ball, Shift Indent - 150cc	1
14	14310	Spring, Shift Indent - 150cc	1
15	14311	Gasket, Shift Indent - 150cc	1
16	14312	Bolt, Shift Indent - 150cc	1
17	14502	Outlet, Drain - 150cc	1
18	14313	Bolt, Drain/Fill Plug - 150cc	2
19	14314	Gasket, Trans Drain Plug - 150cc	2
20	14296	Bolt, M6 x 1.00 x 12 FHCS	2
21	14315	Washer, M6 Flat	2
22	14287	Pin, M10 x 14 Dowel	2
23	14316	Spacer, M15 Inner Gear	1
24	Y00055	Bearing, 6202 15 x 35 x 11	1
25	50102	Bearing, 6203 17 x 40 x 12	1
26	82407	Bearing, 6204 20 x 47 x 14	1
27	14106	Circlip, M20	1
28	14503	Bearing, 6302 15 x 42 x 13	1
29	14504	Bearing, RNA4905 30 x 42 x 17	1
30	14505	Bushing, Shock Absorbing - 150CC	2
31	14318	Seal, M30 x 40 x 6	1
32	82874	Bearing, 6205 25 x 52 x 15	1
33	14506	Spacer, M25 x 34 x 1	1
34	14319	Circlip, M25	1
35	14320	Circlip, M52	1
36	14321	Clamp, Wire	1
37	14235	Bolt, M6 x 1.00 x 40 FHCS	10

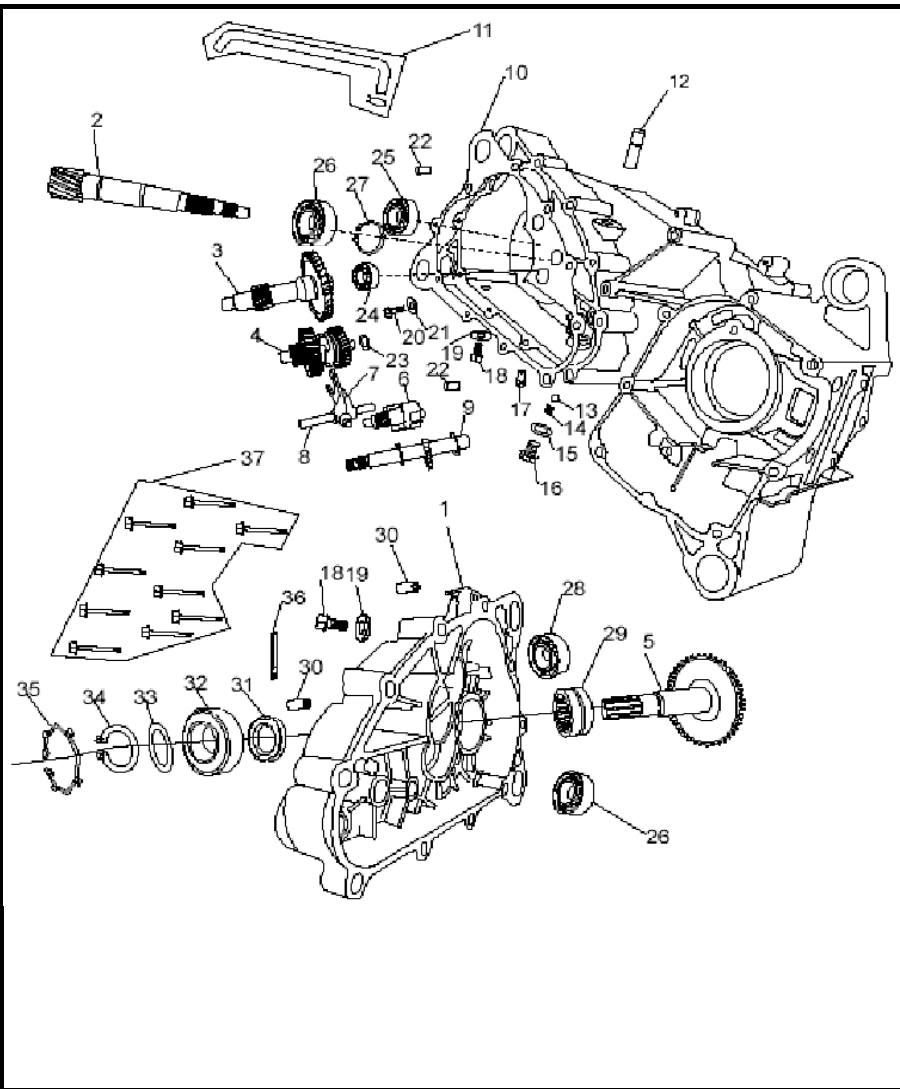

Section 5 - CVT Cover

Ref. #	Part #	Description	Qty.
1	14323	Cover, CVT - 150cc	1
2	14507	Bracket, Exhaust - 150cc	1
3	14324	Nut, M12 x 1.25 Locking Flange	1
4	14508	Bearing, 6200 10 x 30 x 9	2
5	14325	Gasket, CVT Cover - 150cc	1
6	14235	Bolt, M6 x 1.00 x 40 FHCS	8
7	14322	Snorkel, CVT - 150cc	1
8	14322	Snorkel, CVT - 150cc	1
9	14509	Clamp, Snorkel - 150cc	2

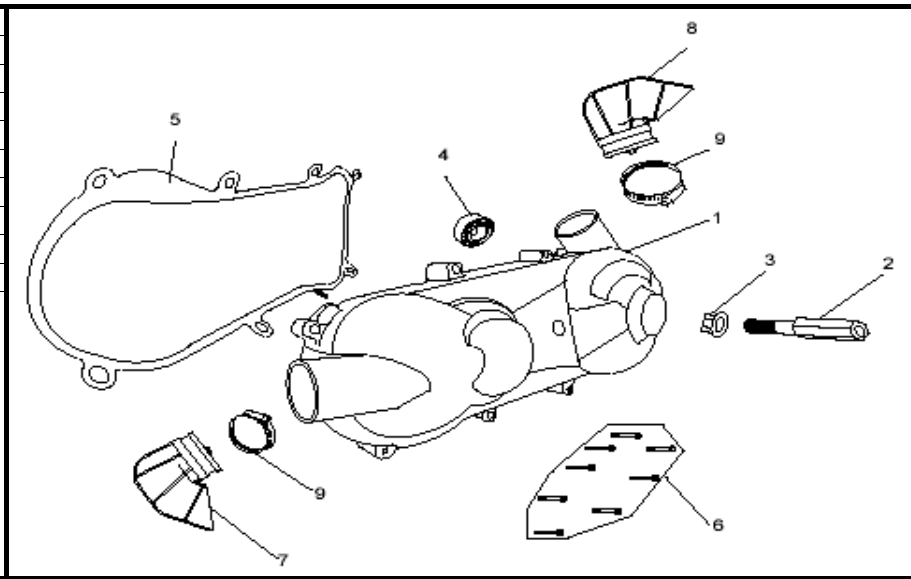

Section 6 - Outer Crankcase Assembly

Ref. #	Part #	Description	Qty.
1	14326	Cover, Outer Crankcase RH - 150cc	1
2	14327	Gasket, Outer Crankcase - 150cc	1
3	14328	Cap, Oil Drain - 150cc	1
4	14329	Screen, Oil Filter - 150cc	1
5	14330	Spring, Oil Filter Screen - 150cc	1
6	14331	Dipstick, Oil Fill - 150cc	1
7	14332	Clamp, AC Generator - 150cc	1
8	14333	Seal, M19.8 x 30 x 5 Oil	1
9	14334	O-Ring, M30.8 x 3	1
10	14335	O-Ring, M18 x 3	1
11	50016	Pin, M8 x 14 Dowel	2
12	14336	Bolt, M6 x 1.00 x 28 FHCS	1
13	14337	Bolt, M6 x 1.00 x 95 FHCS	4
14	14338	Bolt, M6 x 1.00 x 100 FHCS	1
15	14339	Bolt, M6 x 1.00 x 110 FHCS	2
16	14340	Bolt, M6 x 1.00 x 35 FHCS	1
17	14341	Bolt, M6 x 1.00 x 20 FHCS	2
18	14296	Bolt, M5 x 0.75 x 12 FHCS	2

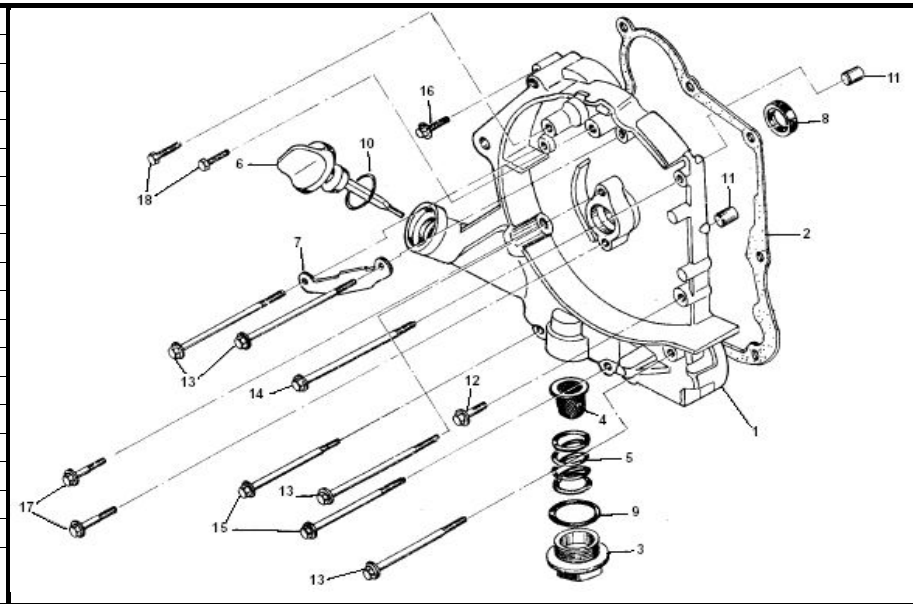

Section 7 - Piston, Crank and Connecting Rod

Ref. #	Part #	Description	Qty.
1	14342	Asm, Crank - Con Rod - 150cc	1
2	14324	Nut, M12 x 1.25 Hex Flange	1
3	14510	Nut, M22 x 1.00 Locking - 150CC	1
4	14511	Washer, M22 x 31 x 2.5 Flat	1
5	14344	Gear, Kick Drive	1
6	14289	Washer, M12 Flat	1
7	14324	Nut, M12 x 1.25 Hex Flange	1
8	14512	Key, Woodruff M4 x 14	1
9	14345	Clip, Piston Retaining - 150cc	2
10	14346	Pin, Piston Wrist - 150cc	1
11	14347	Piston - 150cc	1
12	14348	Kit, Piston Ring - 150cc	1

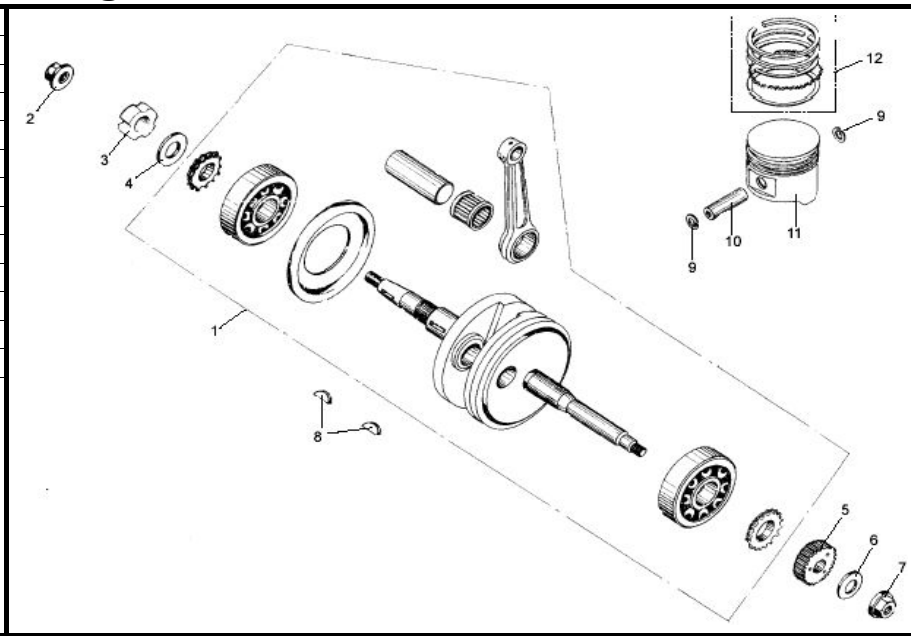

Section 8 - Camshaft Assembly

Ref. #	Part #	Description	Qty.
1	14513	Nut, M5 x 0.5 Hex	2
2	14349	Screw, Tappet Adjustment - 150cc	2
3	14350	Arm, Valve Rocker - 150cc	2
4	14351	Shaft, Exhaust Rocker Arm - 150cc	1
5	14352	Chain, Camshaft - 150cc	1
6	14353	Camshaft - 150cc	1
7	14354	Shaft, Intake Rocker Arm - 150cc	1
8	14355	Plate, Stop - 150cc	1
9	14266	Pin, M10 x 16 Dowel	2
10	14356	Cap, Camshaft Brg - 150cc	1

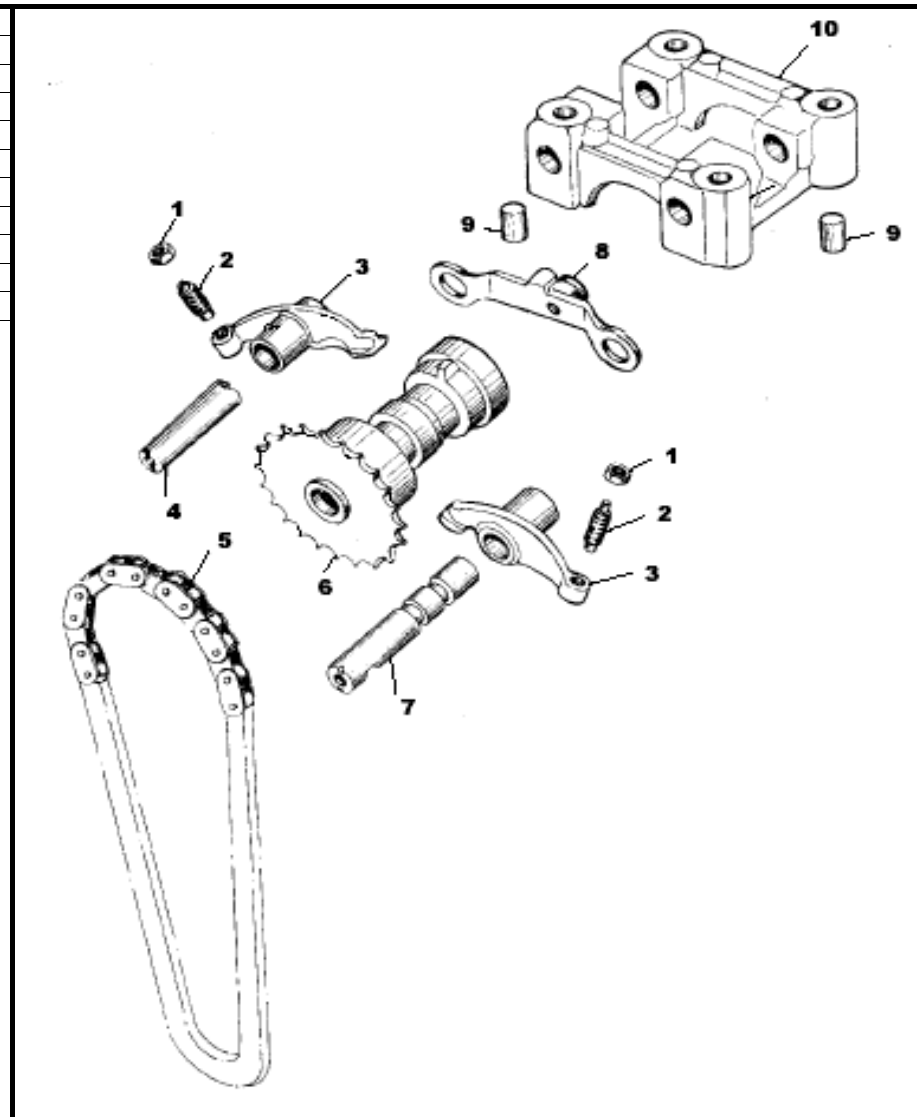

Section 9 - Oil Pump Assembly

Ref. #	Part #	Description	Qty.
1	14357	Chain, Oil Pump - 150cc	1
2	14358	Nut, M6 x 1.00 Hex Flange	1
3	14359	Sprocket, Oil Pump - 150cc	1
4	14360	Bolt, M6 x 1.00 x 30 FHCS	2
5	14361	Asm, Oil Pump - 150cc	1

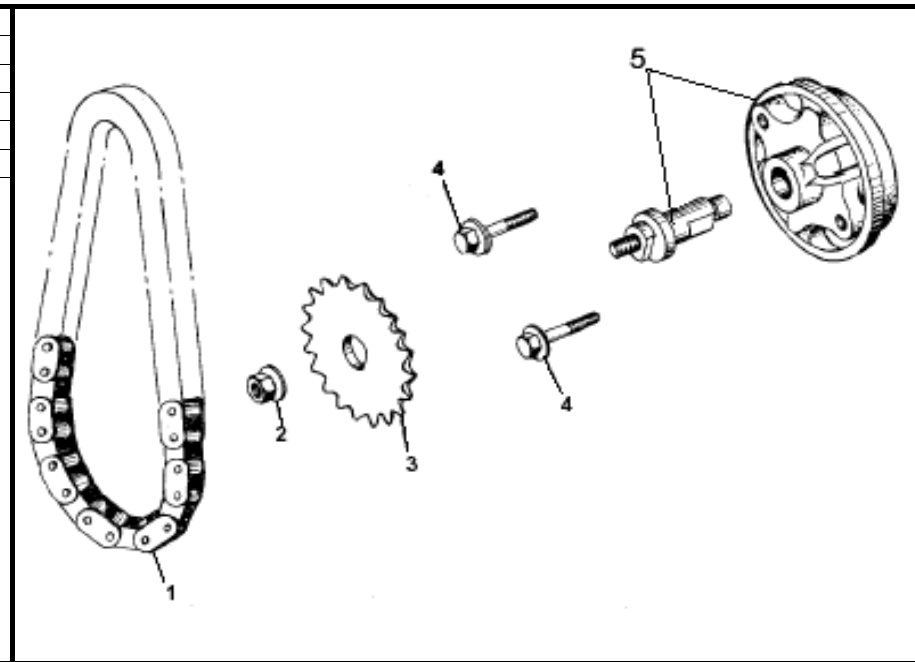

Section 10 - Driven Pulley and Clutch

Ref. #	Part #	Description	Qty.
1	14362	Asm, Outer Clutch - 150cc	1
2	14363	Belt, CVT - 150cc	1
3	14364	Asm, Driven Pulley - 150cc	1

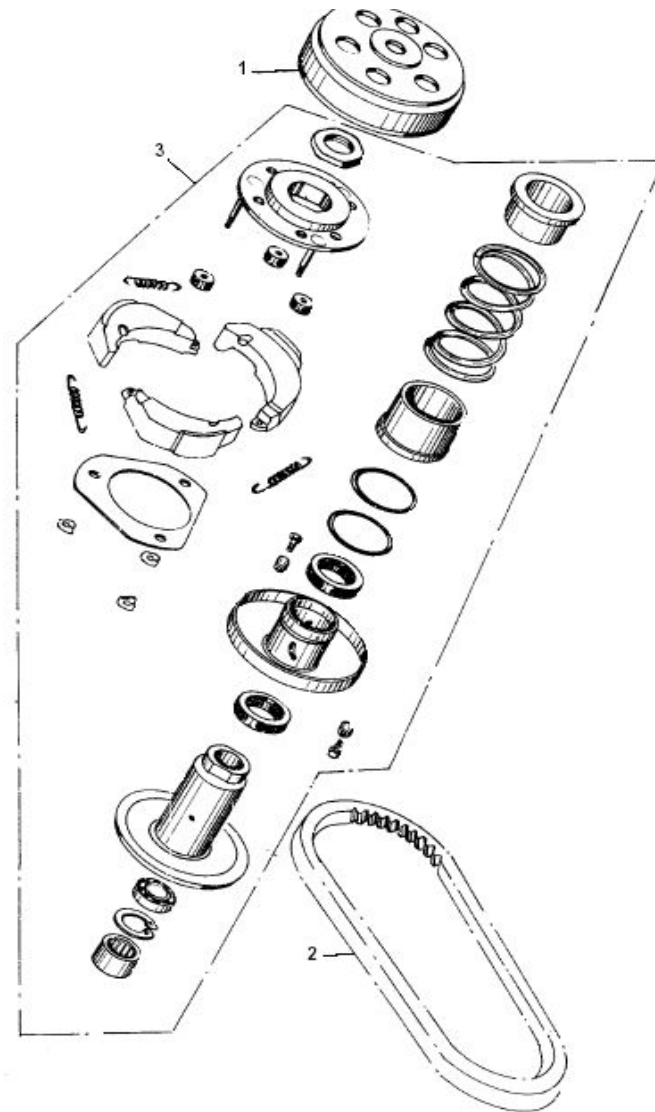

Section 11 - Engine Electrical

Ref. #	Part #	Description	Qty.
1	14365	Magneto - 150cc	1
2	14366	Flywheel - 150cc	1
3	14367	Fan, Cooling - 150cc	1
4	14368	Bolt, M6 x 1.00 x 15 FHCS	4

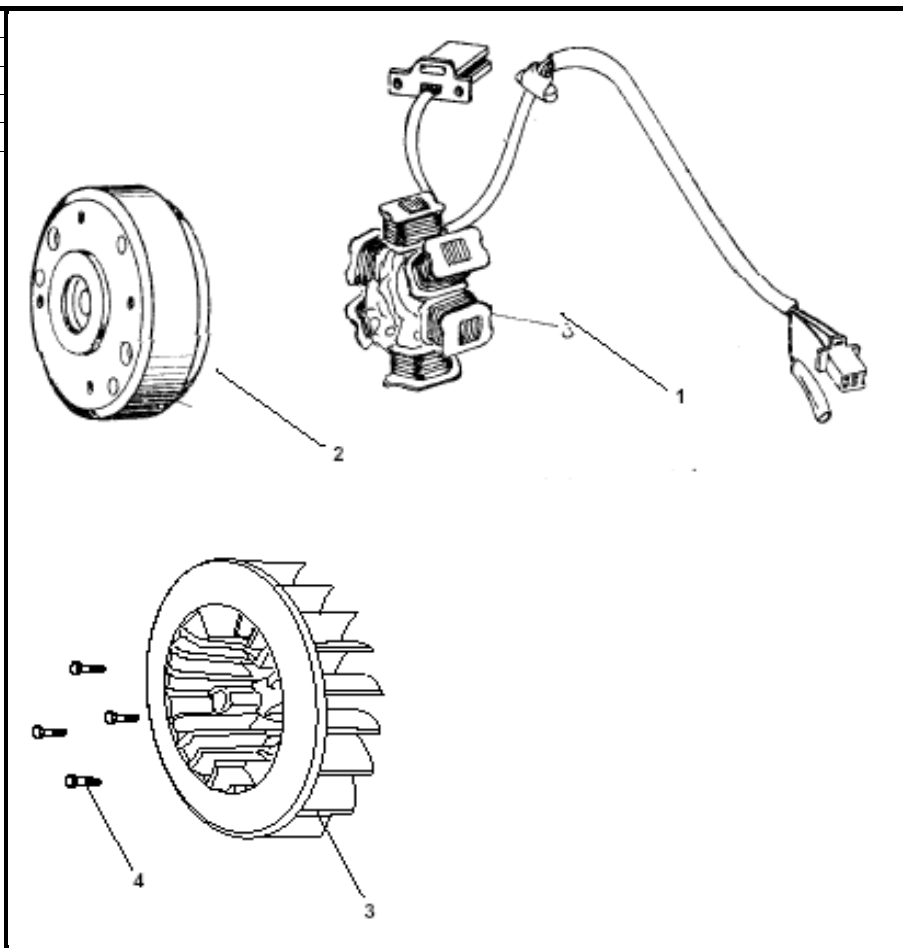

Section 12 - Electric Start

Ref. #	Part #	Description	Qty.
1	14369	Asm, Starter Clutch - 150cc	1
2	14370	Shaft, Starter Red - 150cc	1
3	14371	Gear, Starter Red - 150cc	1
4	14372	Bolt, M6 x 1.00 x 16 FHCS	2
5	14373	Asm, Starter Motor - 150cc	1

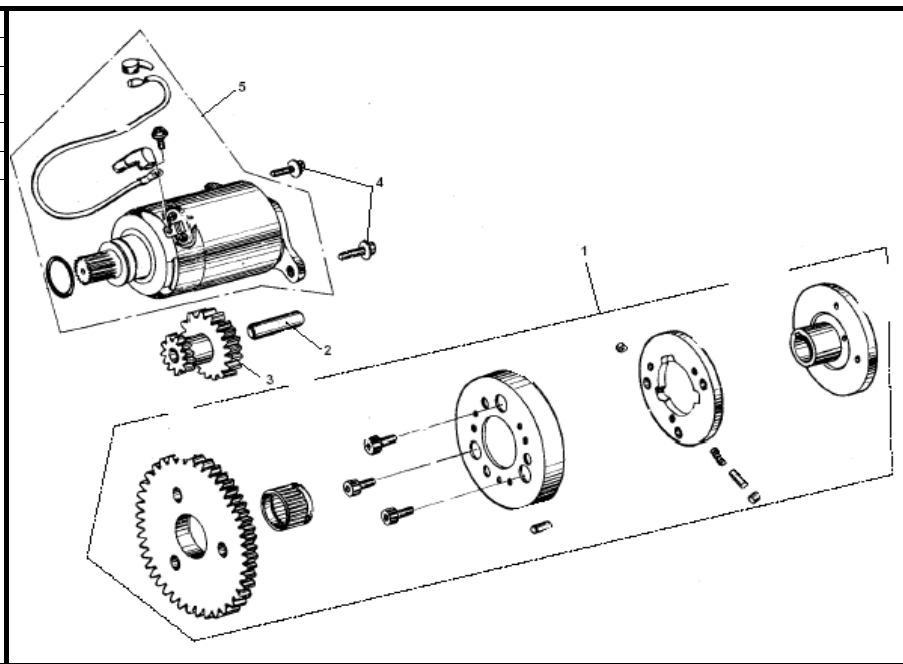

Section 13 - Driver Pulley

Ref. #	Part #	Description	Qty.
1	14374	Asm, Driver Pulley - 150cc	1
2	14375	Weights, Driver Pulley - 150cc	6

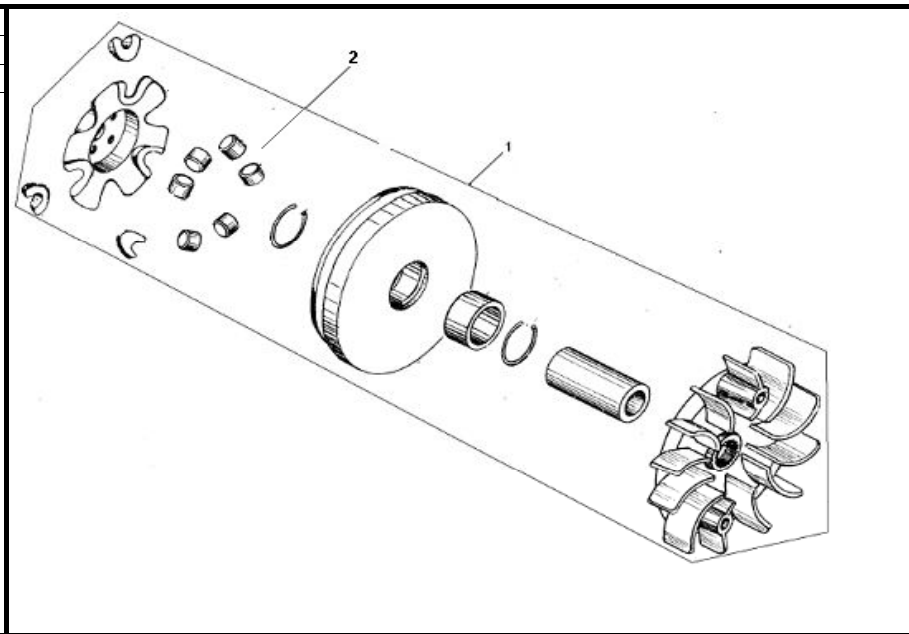

Section 14 - Oil Cooler (Not Included on 6150 Models)

Ref. #	Part #	Description	Qty.
1	14376	Manifold, Oil Cooler - 150cc	1
2	14514	Filter, Oil - 150cc	1
3	14537	Bolt, M12 X 28 Brake Banjo	4
4	14538	Washer, Oil Line	8
5	14515	Hose, Oil Cooling - 150cc	2
6	14560	Seal, Oil Filter	1

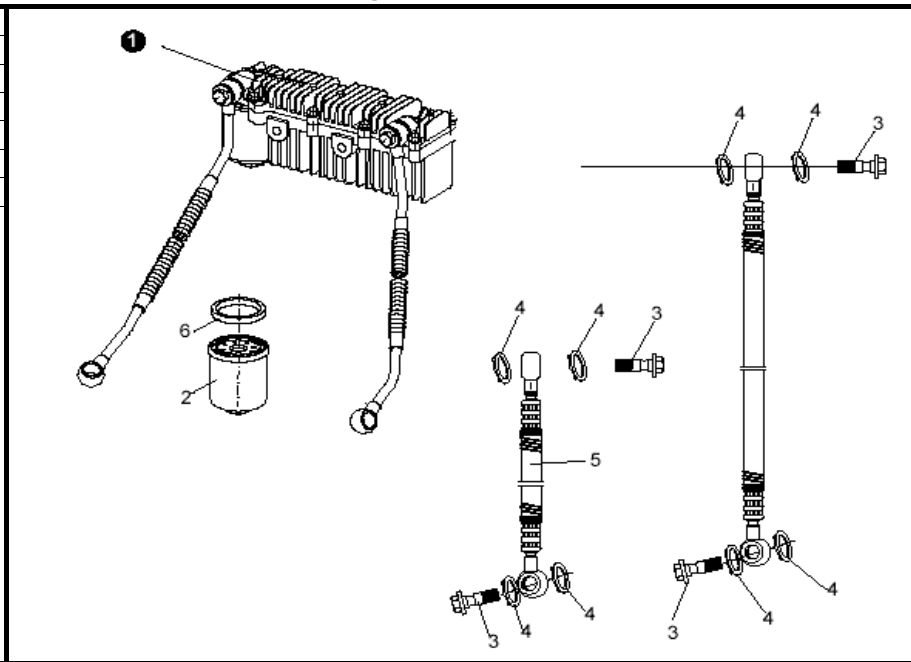

Section 15 - Fan Cover and Shroud Assembly

Ref. #	Part #	Description	Qty.
1	14540	Cover, Fan Comp - 150cc	1
2	14541	Cover, Dust - 150cc	1
3	14542	Duct, Carburetor Cooling - 150cc	1
4	14543	Shroud, Lower - 150cc	1
5	14544	Seal, Lower Shroud - 150cc	1
6	14545	Shroud, Upper - 150cc	1
7	14546	Clip, Cord - 150cc	1
8	14547	Seal, Upper Shroud - 150cc	1
9	50065	Screw,	6
10	50069	Bolt, M6 x 25 FHCS	3
11	14539	Screw, 3.5 x 13 STFH	3

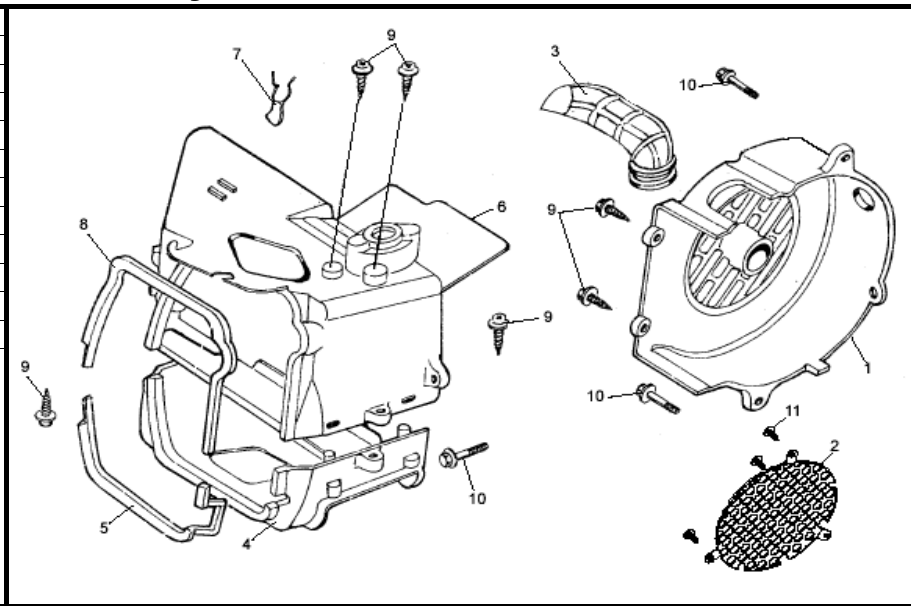

Section 16 - Carburetor

Ref. #	Part #	Description	Qty.
1	14561	KIT, CARB GASKET - 150CC	1
2	14562	KIT, CARB VACUUM - 150CC	1
3	14563	KIT, CARB CHOKE - 150CC	1
4	14564	KIT, CARB REBUILD - 150CC	1
5	14565	SCREW, M5 X 12 PH	3
6	14566	SCREW, M4 X 14 PH	2
7	14567	SCREW, M4 X 10 PH	2

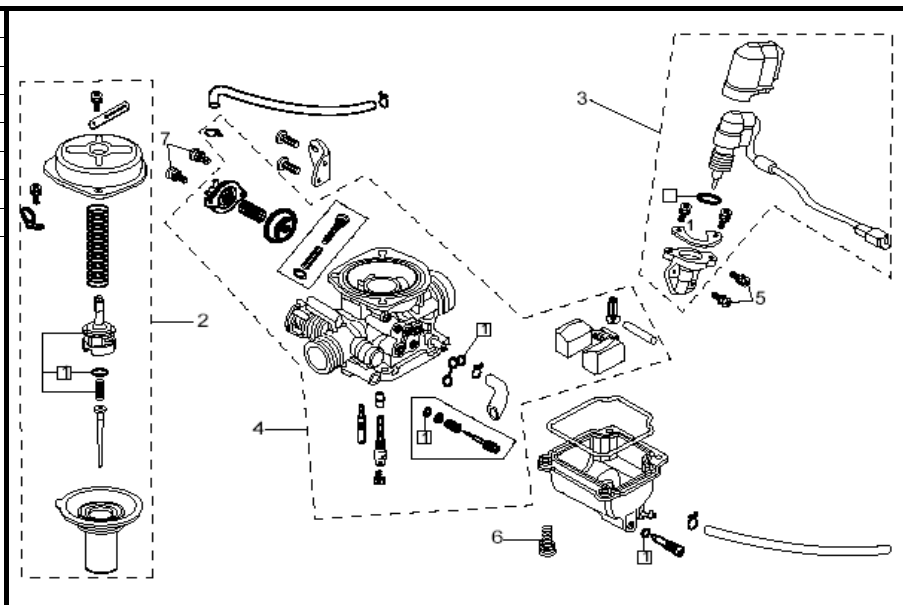

Section 17 - Frame Group

Ref. #	Part #	Description	Qty.
1	14379-48	Bar, Rear C Pillar - 6150 Charcoal	1
	14379-49	Bar, Rear C Pillar - 6150 Red	
	14379-51	Bar, Rear C Pillar - 6150 PO Blue	
2	14380-48	Bar, OH Cross - 6150 Charcoal	1
	14380-47	Bar, OH Cross - 6150 Silver	
	14380-50	Bar, OH Cross - 6150 Aegean Blue	
3	14381-48	Bar, LH B Pillar - 6150 Charcoal	1
	14381-49	Bar, LH B Pillar - 6150 Red	
	14381-51	Bar, LH B Pillar - 6150 PO Blue	
4	14382-48	Bar, RH B Pillar - 6150 Charcoal	1
	14382-49	Bar, RH B Pillar - 6150 Red	
	14382-51	Bar, RH B Pillar - 6150 PO Blue	
5	14421	Screw, M4 x 0.75 x 15	2
6	14383-48	Plate, Front Decal - 6150 Charcoal	1
	14383-49	Plate, Front Decal - 6150 Red	
	14383-51	Plate, Front Decal - 6150 PO Blue	
7	14087	Washer, Concave Clamp	12
8	14086	Bolt, M8 x 1.25 x 55 FHCS	6
9	14088	Nut, M8 x 1.25 Locking Flange	6
10	14548	Guard, Steering Chain - Right	1
11	14384-48	Bar, OH Front - 6150 Charcoal	1
	14384-47	Bar, OH Front - 6150 Silver	
	14384-50	Bar, OH Front - 6150 Aegean Blue	
12	14083	Endcap, Bar - 1 1/4"	4
13	14426	Bolt, M6 x 1.00 x 14 FHCS	4
14	14084	Endcap, Bar - 1"	2
15	14094	Cable, Throttle	1
16	14456	Cable, D/N/R Shift - 150CC	2
17	14549	Guard, Steering Chain - Left	1
18	14235	Bolt, M6 x 1 x 40 FHCS	4
19	14517	Pad, Foam B Pillar Wrapped - 6150 Black	2

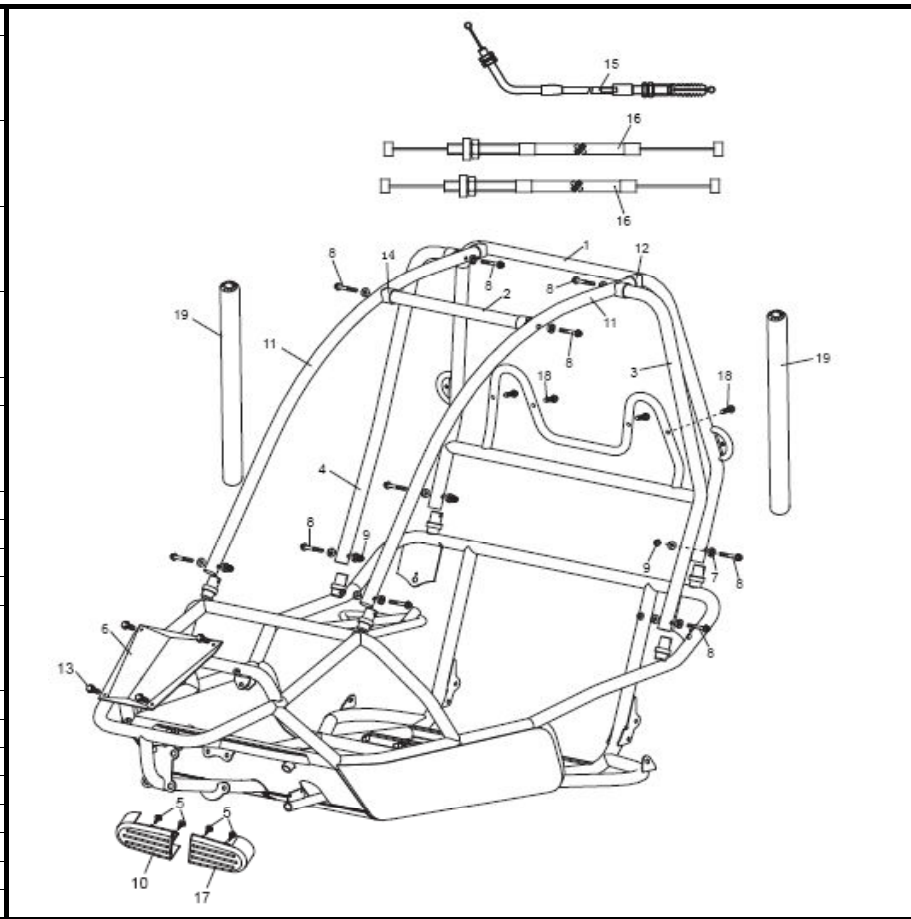

Section 18 - Steering Assembly

Ref. #	Part #	Description	Qty.
1	14100	Cover, Steering Wheel	1
2	14237	Bolt, M6 x 1 x 12 HHCS	3
3	14102	Steering Wheel	1
4	14385	Shaft, Steering - 6150	1
5	14104	Bushing, Steering Shaft	3
6	14432	Bolt, M8 x 1.25 x 12 FHCS	1
7	14518	Sprocket, 06B-13T Steel	1
8	14293	Washer, M8 Flat	1
9	14435	Bolt, M8 x 1.25 X 22 FHCS	1
10	14519	Chain, KMC 06B-1RX82L	1
11	14520	Circlip, M15	1
12	14521	Link, Steering Chain	1
13	14550	Washer, 18 x 8.2 x 2.5	1
14	14522	Sprocket, 06B-13T - Plastic	1
15	14523	Shaft, Steering Adjustment - 6150	1
16	14088	Nut, M8 x 1.25 Locking Flange	1
17	14439	Bolt, M8 x 1.25 X 40 FHCS	1
18	14238	Washer, M6 Split Lock	2
19	14496	Washer, M5 Flat ZN	2
20	14088	Nut, M8 x 1.25 Locking Flange	1
21	14441	Bolt, M8 x 1.25 x 100 FHCS	1
22	14430	Bolt, M6 x 1 x 25 FHCS	2
23	14386	Asm, Hyd Brake - 6150	1
24	14524	Kit, Brake Pad - 6150	1
25	14426	Bolt M6 x 1 x 14 FHCS	1
26	14442	Bolt, M8 x 1.25 x 145 HHCS	1
27	14120	Spring, Brake Pedal	1
28	14119	Bushing, Pedal	4
29	14387-48	Pedal, Brake - 6150 - Charcoal	1
29	14387-47	Pedal, Brake - 6150 - Silver	2
30	14236	Nut, M6 x 1	2
31	14430	Bolt, M6 x 1 x 25 FHCS	1
32	14388-48	Pedal, Throttle - 6150 - Charcoal	1
32	14388-47	Pedal, Throttle - 6150 - Silver	1
33	14113	Spring, Throttle Pedal	1
34	14389	Cap, Brake Master Cylinder - 6150	1
35	14525	Hose, Brake - 6150	1
36	14390	Asm, Brake Caliper - 6150	1
37	14526	Cap, Throttle Pedal - 6150	1
38	14527	Cap, Brake Pedial - 6150	1
39	14437	Bolt, M8 x 1.25 x 25 FHCS	1
40	14088	Nut, M8 x 1.25 Locking Flange	1
41	14528	Lever, Parking Brake - 6150	1

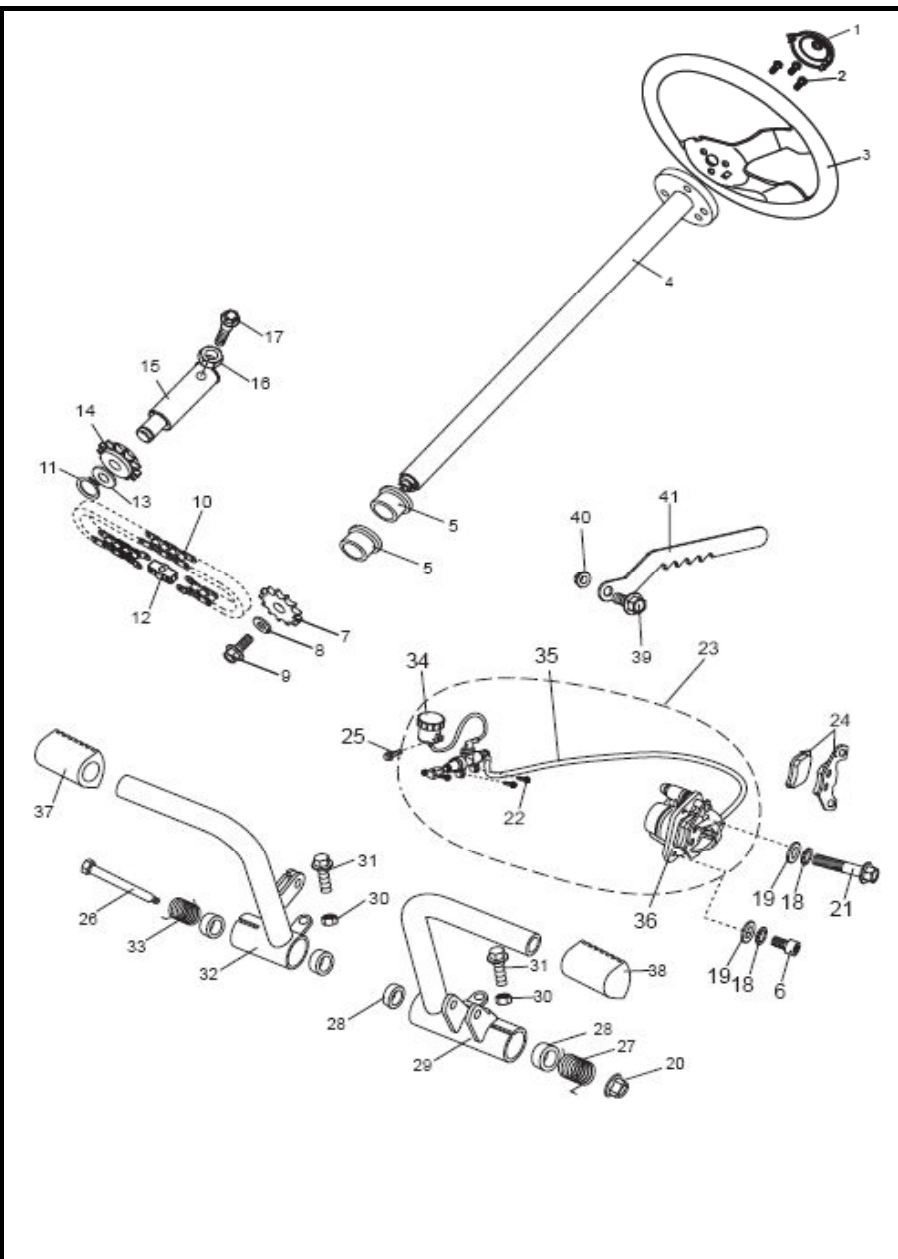

Section 19 - Front Suspension

Ref. #	Part #	Description	Qty.
1	14450	Bolt, M10 X 1.25 X 232 HHCS	4
2	14154	Cap, Dust - Lower Suspension Arm	8
3	14155	Bushing, A Arm Lower	8
4	14391-48	A Arm, Lower - 6150 Charcoal	2
	14391-47	A Arm, Lower - 6150 Silver	2
5	14246	Bolt, M10 x 1.25 x 40 FHCS	8
6	14392-48	A Arm, Upper - 6150 - Charcoal	2
	14392-47	A Arm, Upper - 6150 - Silver	2
7	14243	Nut, M10 x 1.25 Locking Flange	16
8	14393	Shock, 345mm Front - Chr/Yellow	2
9	14087	Washer, Concave Clamp	2
10	14394	Asm, Strut/Spindle - LH - Black	1
11	14244	Nut, M12 x 1.25 Castle ZN	4
12	14137	Seal, Ball Joint	4
13	14138	Spacer, Ball Joint Head	4
14	14147	Stud, M10 x 1.25 x 31 Wheel	8
15	14149	Bearing, Outer 6202-Z	2
16	14145	Seal, 47 x 25 x 7 Dust	2
17	14146	Bearing, Inner - 6204-Z	2
18	14395	Asm, Strut/Spindle - RH - Black	1
19	14148	Hub, Front Wheel	2
20	14529	End, Tie Rod - M10	2
21	14551	Washer	4
22	14552	Tie Rod - 360 x M10 x 1.5	2
23	14396	Asm, Tire/Wheel LF	1
24	14430	Bolt, M6 x 1 x 25	2
25	14553	Nut, Tie Rod - M10 x 1.5	2
26	14397	Asm, Tire/Wheel RF	1
27	14554	Nut, Tie Rod - M10 x 1.5	2
28	14244	Nut, M12 x 1.25 Castle ZN	2
29	14150	Pin, M2 x 20 Cotter	2
30	14151	Cap, Hub Nose	2
31	14555	Bushing, 21 x 15 x 15	2
32	14448	Bolt, M10 X 1.25 X 85 HHCS	2
33	14556	End, Tie Rod - M10 x 1.5	2
34	14400	Pivot, Steering Link - 6150 Charcoal	1
35	14236	Nut, M6 x 1 - Nyloc Flange	2
36	14156	O-Ring, M21.2 x 2.65	8
37	14490	Pin, M1.8 x 20 Cotter	4
38	14245	Washer, M12 Split Lock ZN	4

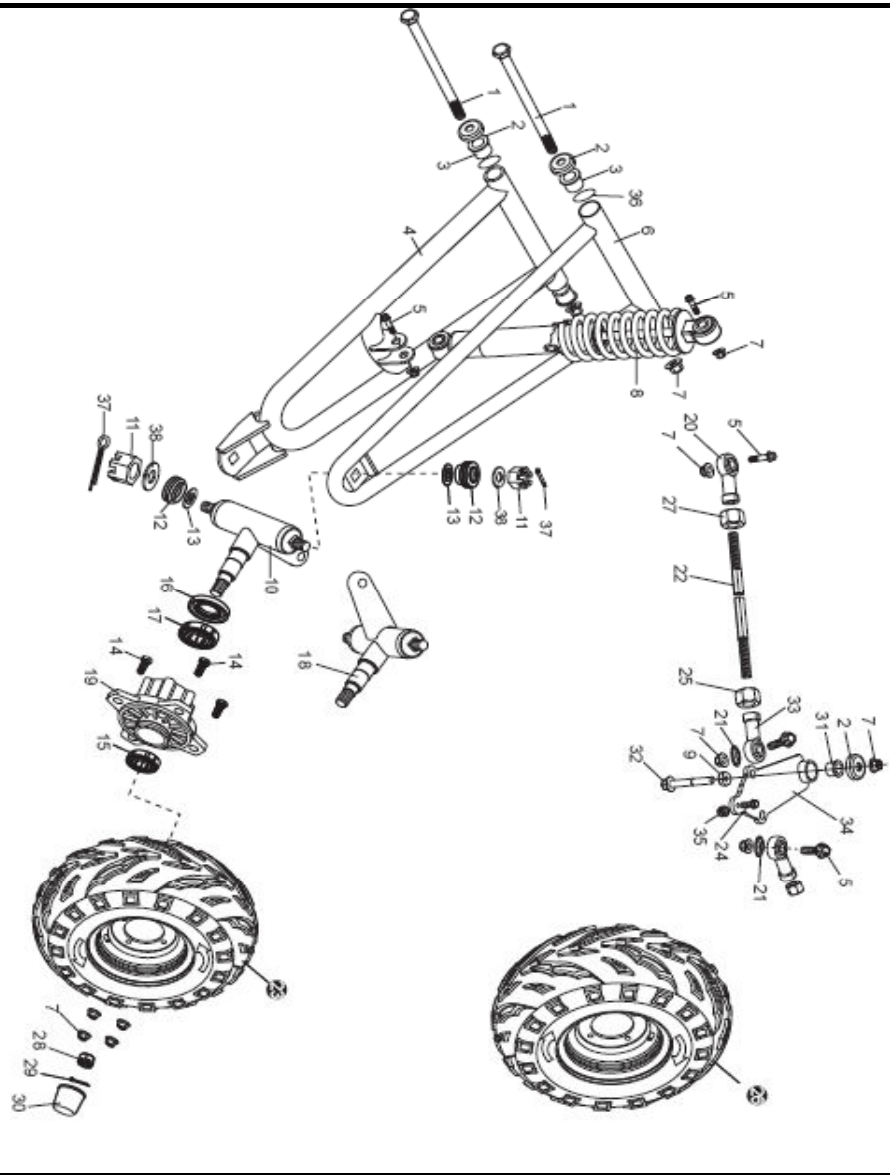

Section 20 - Rear Cargo Rack

Ref. #	Part #	Description	Qty.
1	14532-48	Cargo Rack - 6150 Charcoal	1
	14532-47	Cargo Rack - 6150 Silver	
	14532-50	Cargo Rack - 6150 Aegean Blue	
2	14083	Endcap, Bar - 1 1/4"	2
3	14404-48	Arm, Rack Suppot - 6150 Charcoal	1
	14404-47	Arm, Rack Suppot - 6150 Silver	
	14404-50	Arm, Rack Suppot - 6150 Aegean Blue	
4	14239	Bolt, M8 x 1.25 x 20 FHCS	4
5	14088	Nut, M8 x 1.25 Locking Flange	4
6	13871	Cap, Fuel	1
7	14161	Tank, Fuel - 6150/7150 Charcoal	1
	14533	Tank, Fuel - 6150 Silver	
	14534	Tank, Fuel - 6150 Aegean Blue	
8	14436	Bolt, M8 x 1.25 x 25 FHCS	4
9	14162	Spacer, Fuel Tank	4
10	14163	Bushing, Fuel Tank Mount	4
11	14293	Washer, M8 Flat	4
12	14088	Nut, M8 x 1.25 Locking Flange	4
13	50210	Asm, Auto Fuel Cock	1
14	14164	Line, Fuel #1	1
15	14165	Line, Vacuum #1	1
16	14166	Line, Fuel #2	1
17	14167	Filter, Fuel	1
18	14087	Washer, Concave Clamp	2
19	14086	Bolt, M8 x 1.25 x 55 FHCS	2
20	14439	Bolt, M8 x 1.25 x 40 HHCS	4
21	14088	Nut, M8 x 1.25 Locking Flange	4
22	14171	Slide, Seat	2
23	14466	Nut, Decorative Plastic Flag Mnt.	1
24	14402	Headrest, Black Bar Mount - 6150	2
25	14403	Seat, Black Vinyl Bench - 6150	1
26	14473	Bracket, Shift Cable	1
27	14479	Disc, Shift Control	1
28	14420	Screw, M4 x 0.75 x 31	1
29	14478	Asm, Trans Shift Lever - F/N/R - 150cc	1
30	14464	Flag, Safety	1
31	14465	Bolt, M12 x 1.25 x 30 Flag Mounting	1
32	8778	Harness, Lap Shoulder Rest	2
33	14324	Nut, M12 x 1.25	4
34	14289	Washer, M12	4
35	14451	Bolt, M12 x 1.25 x 25	4
36	14492	Nut, M12 x 1.25	1
37	14493	Nut, M4 x 0.7	1

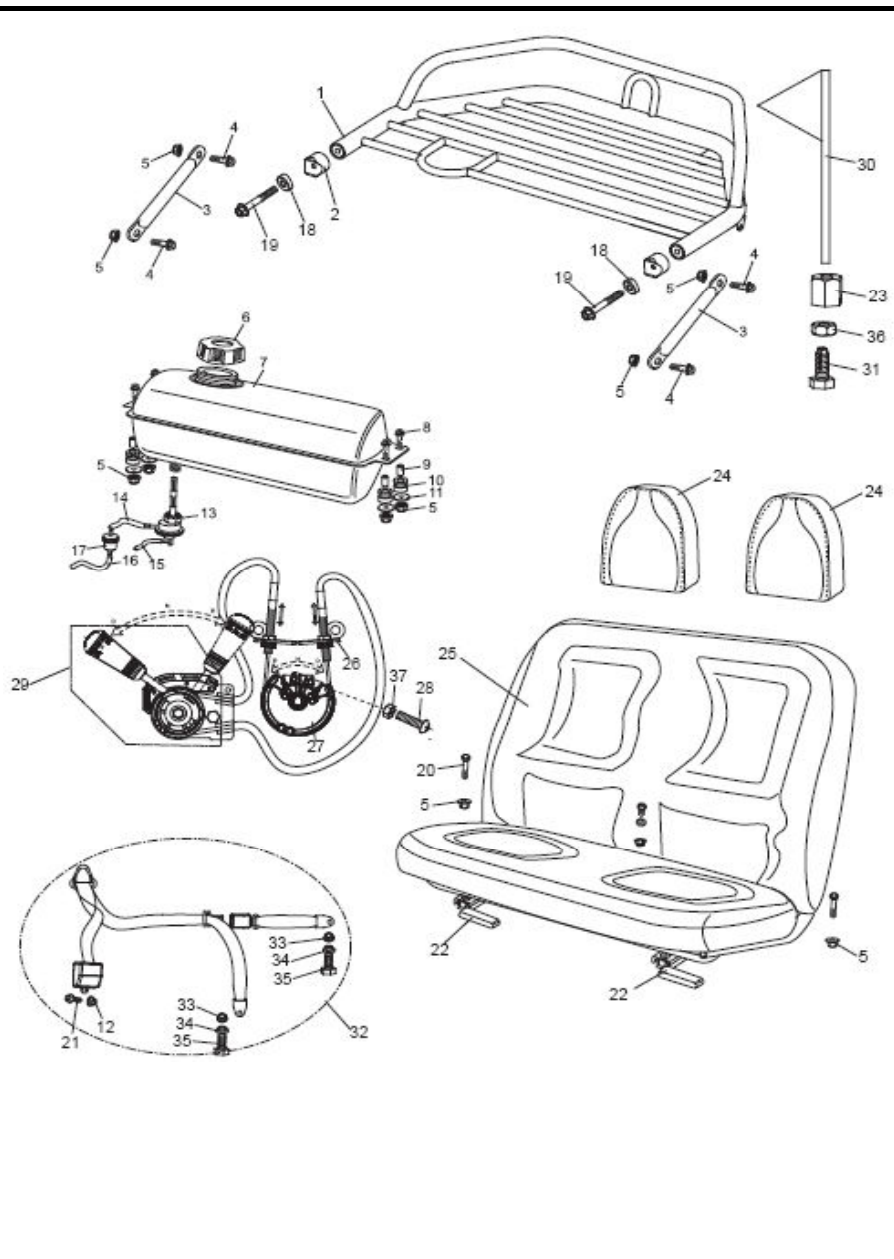

Section 21 - Rear Swingarm

Ref. #	Part #	Description	Qty.
1	14324	Nut, M12 x 1.25 Locking Flange	1
2	14289	Washer, M12 Flat ZN	1
3	14467	Bushing, Engine Adj Isolator	1
4	14468	Spacer, Engine Adj Cup	1
5	14469	Spacer, Engine Adj Alignment	1
6	14188	Gasket, Battery Cap - 150cc	1
7	14492	Nut, M12 x 1.25 Hex ZN	1
8	14470	Link, Chain Tensioning - 150cc	1
9	14243	Nut, M10 x 1.25 Locking Flange	1
10	14446	Bolt, M6 x 1 x 45 FHCS	1
11	14471	Spacer, Engine Mounting Link - 150cc	1
12	14405-48	Asm, Rear Swingarm - 6150 Charcoal	1
	14405-47	Asm, Rear Swingarm - 6150 Sliver	
13	14431	Screw, M6 x 1 x 60 PHCS	2
14	14172	Cover, Electrical	1
15	14246	Bolt, M10 x 1.25 x 40 FHCS	4
16	14243	Nut, M10 x 1.25 Locking Flange	5
17	14535	Shock, Rear - 6150	2
18	14324	Nut, M12 x 1.25 Locking Flange	2
19	14191	Bushing, Swingarm Isolator - 150cc	2
20	14452	Bolt, M12 x 1.25 x 60 FHCS	2
21	14372	Bolt, M6 x 1 x 16 FHCS	4
22	14185	Guard, Lower Chain - 150cc	1
23	14189	Battery - YTX12-BS	1
24	14186	Cover, Battery - 150cc	1
25	14177	Spanner, Engine Mount	1
26	14449	Bolt, M10 x 1.25 x 195 HHCS	1
27	14187	Strap, Battery Hold Down - 150cc	1

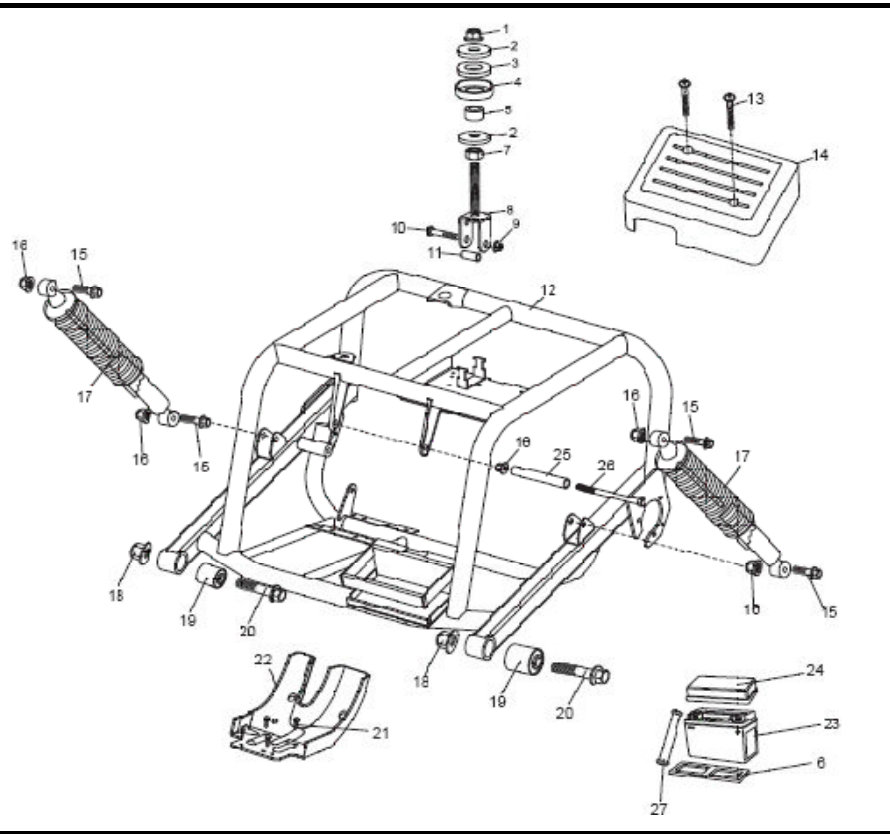

Section 22 - Engine

Ref. #	Part #	Description	Qty.
1	14192	Asm, Air Cleaner - 150cc	1
2	14193	Screw M5 x 16 Self Tapping PH	9
3	14495	Washer, M8 Split Lock ZN	1
4	14194	Filter, Air - 150cc	1
5	14201	Bracket, #2 Air Cleaner Mount - 150cc	1
6	14497	Washer, M8 x 27 x 2 FLAT ZN	1
7	14195	Hose, Air Intake - 150cc	1
8	14481	Clamp, Hose - 45	1
9	14196	Gasket, Exhaust Pipe - 150cc	1
10	14197	Asm, Carburetor - 150cc	1
11	14198	Asm, Engine - 150cc	1
12	14482	Spring, Exhaust Pipe	2
13	50050	Nut (Hex) Cap M6	2
14	14480	Bracket, Rear Eng Mount - 150cc	2
15	14483	Clamp - 50	1
16	14199	Asm, Muffler - 150cc	1
17	14433	Bolt, M8 x 1.25 x 15 FHCS ZN	1
18	14439	Bolt, M8 x 1.25 x 40 FHCS ZN	1
19	14239	Bolt, M8 x 1.25 x 20 FHCS ZN	3
20	14200	Bracket, #1 Air Cleaner Mount - 150cc	1
21	14445	Bolt, M10 x 1.25 x 10 FHCS ZN	1
22	14484	Guard, Chain - 150cc	1
23	14426	Bolt, M6 x 1 x 14 FHCS ZN	2
24	14434	Bolt, M8 x 1.25 x 16 FHCS ZN	1

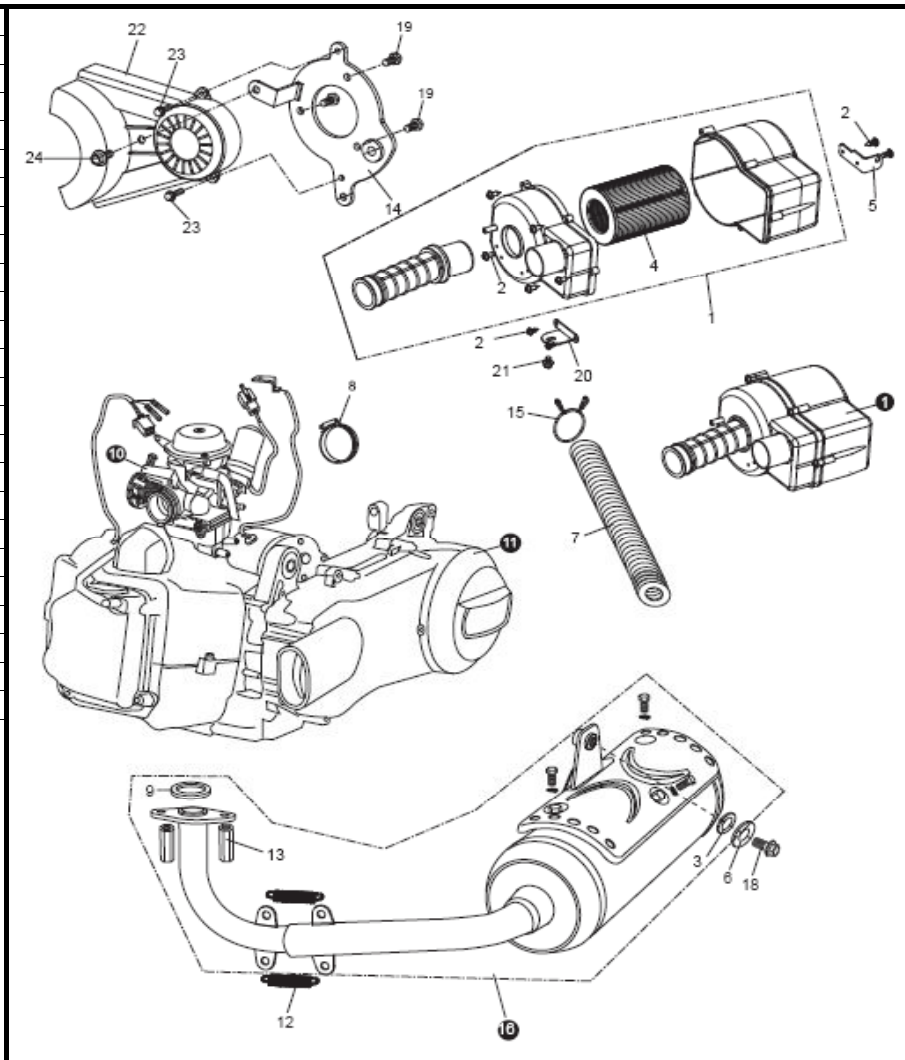

Section 24 - Electrical

Ref. #	Part #	Description	Qty.
1	14227	Coil, Ignition w/ Cap - 150cc	1
2	14406	Panel, Dash - 6150	1
3	14221	Switch, Engine Stop - 150cc	1
4	14222	Switch, Keyed Ignition - 150cc	1
5	14407	Harness, Main Wiring - 6150	1
6	14223	Harness, Battery - 150cc	1
7	14428	Screw, M6 x 1 x 20	2
8	14236	Nut, M6 x 1.00 Nyloc Hex	2
9	14224	Regulator, Voltage - 150cc	1
10	14225	Relay, Starter - 150cc	1
11	14226	CDI - 150cc	1
12	14491	Nut, M5 x 0.75 Nyloc	1
13	14425	Screw, M5 x 0.75 x 25	1
14	14231	Fuse, 15 Amp - Waytek 46115	2

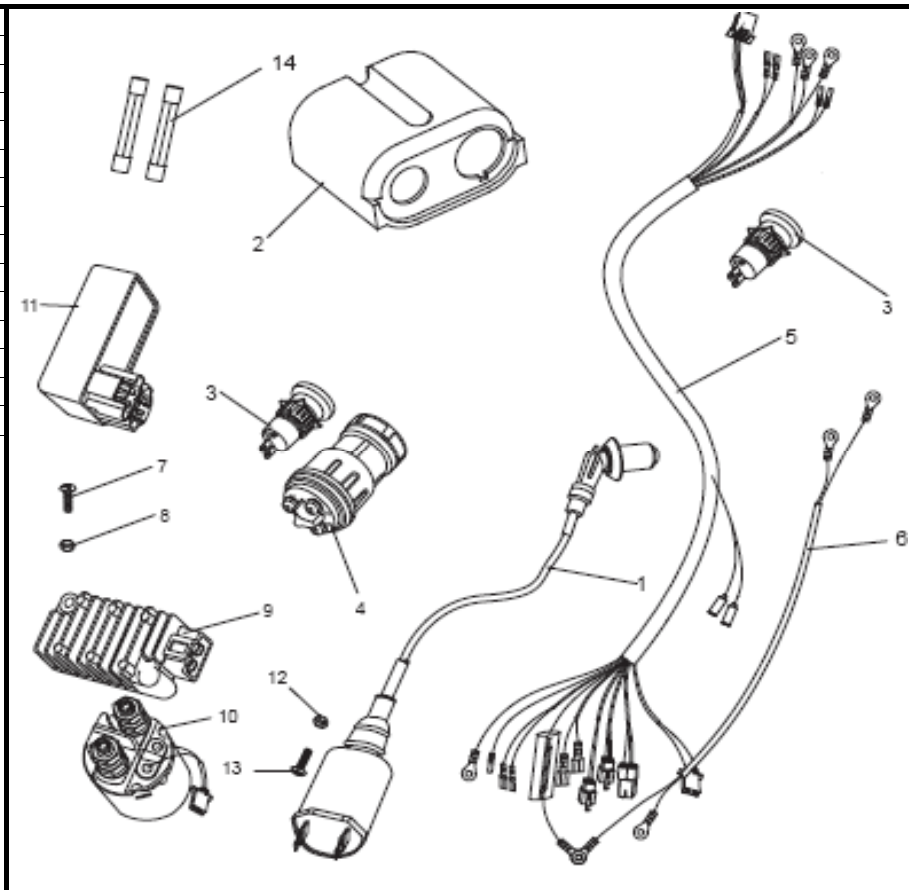

ORDERING PARTS

FAST & EASY!

- 1) Seek Part(s) from your models illustrated diagram, cross over REF# to PART#
- 2) Type PART# into sites [Search Box] at GoKartsRus.com TIP! - RIGHT CLICK LINK, SELECT OPEN IN NEW TAB
- 3) Add all needed parts to Shopping Cart | Complete "Checkout" | ✓ Done!

If a part does not come up in a Site Search, please [Contact Us](#) (include part# in email)

LOWEST PRICES!