



6152 ZIRCON

150CC FUN KART

ORDERING PARTS

FAST & EASY!

LOWEST PRICES!

1) Seek Part(s) from your models illustrated diagram, cross over REF# to PART#

2) Type PART# into sites [Search Box] at GoKartsRus.com TIP! - RIGHT CLICK LINK, SELECT OPEN IN NEW TAB

3) Add all needed parts to Shopping Cart | Complete "Checkout" | ✓ Done!

If a part does not come up in a Site Search, please [Contact Us](#) (include part# in email)



150CC FUN KART

ILLUSTRATED PARTS LIST

TABLE OF CONTENTS

SECTION 1 CYLINDER HEAD ASSEMBLY	1
SECTION 2 CYLINDER	2
SECTION 3 ENGINE CRANKCASE	3
SECTION 4 TRANSMISSION	4
SECTION 5 CVT COVER	5
SECTION 6 OUTER CRANKCASE ASSEMBLY	6
SECTION 7 PISTON / CRANK / CONNECTING ROD	7
SECTION 8 CAMSHAFT ASSEMBLY	8
SECTION 9 OIL PUMP ASSEMBLY	9
SECTION 10 DRIVEN PULLEY & CLUTCH	10
SECTION 11 ENGINE ELECTRICAL	11
SECTION 12 ELECTRIC START	12
SECTION 13 DRIVER PULLEY	13
SECTION 14 FAN COVER / SHROUD ASSEMBLY	14
SECTION 15 CARBURETOR	15
SECTION 16 FRAME GROUP WARNING LABELS	16
SECTION 17 FRAME GROUP	17-18
SECTION 18 STEERING & BRAKES	19
SECTION 19 FRONT SUSPENSION	20
SECTION 20 REAR SWINGARM ASSEMBLY	21
SECTION 21 ENGINE / MUFFLER / AIR CLEANER	22
SECTION 22 REAR AXLE	23
SECTION 23 ELECTRICAL	24

6152 SECTION 1 CYLINDER HEAD ASSEMBLY

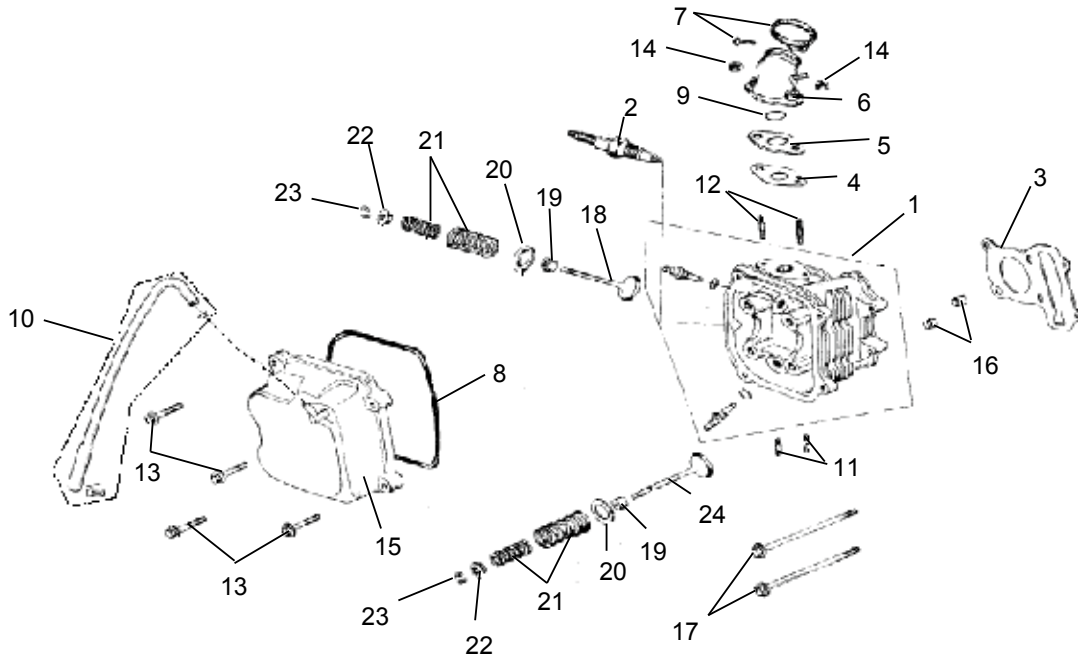

Ref#	Part#	Description	Qty
1	14254	HEAD, CYLINDER - 150CC	1
2	50304	SPARK PLUG (CR7HSA)	1
3	14255	GASKET, CYL HEAD - 150CC	1
4	14256	GASKET, CARB INSULATOR - 150CC	1
5	14257	INSULATOR, CARB - 150CC	1
6	14258	MANIFOLD, INTAKE - 150CC	1
7	14259	CLAMP, CARB HOSE - 150CC	1
8	14260	GASKET, VALVE COVER - 150CC	1
9	14261	O-RING, M27 X 2 RUBBER - 150CC	1
10	14262	TUBE, BREATHER - 150CC	1
11	14263	STUD, M6 X 1.25 X 18	2
12	14264	STUD, M6 X 1.25 X 50	2

Ref#	Part#	Description	Qty
13	50003	BOLT, M6 x 1.00 x 25 HHF	4
14	50024	NUT, M6 x 1.00 HEX FLANGE	2
15	14265	COVER, VALVE - 150CC	1
16	14266	PIN, M10 X 16 DOWEL	2
17	50087	BOLT FLANGE SH 6 X 100	2
18	14267	VALVE, INTAKE - 150CC	1
19	14268	SEAL, VALVE STEM - 150CC	2
20	14269	SEAT, VALVE SPRING OUTER - 150CC	2
21	14270	SPRING, OUTER AND INNER VALVE - 150CC	2
22	14271	RETAINER, VALVE SPRING - 150CC	2
23	14272	KEEPER, VALVE SPRING - 150CC	4
24	14273	VALVE, EXHAUST - 150CC	1

NOTE: parts denoted as left or right hand are from driver's point of view.

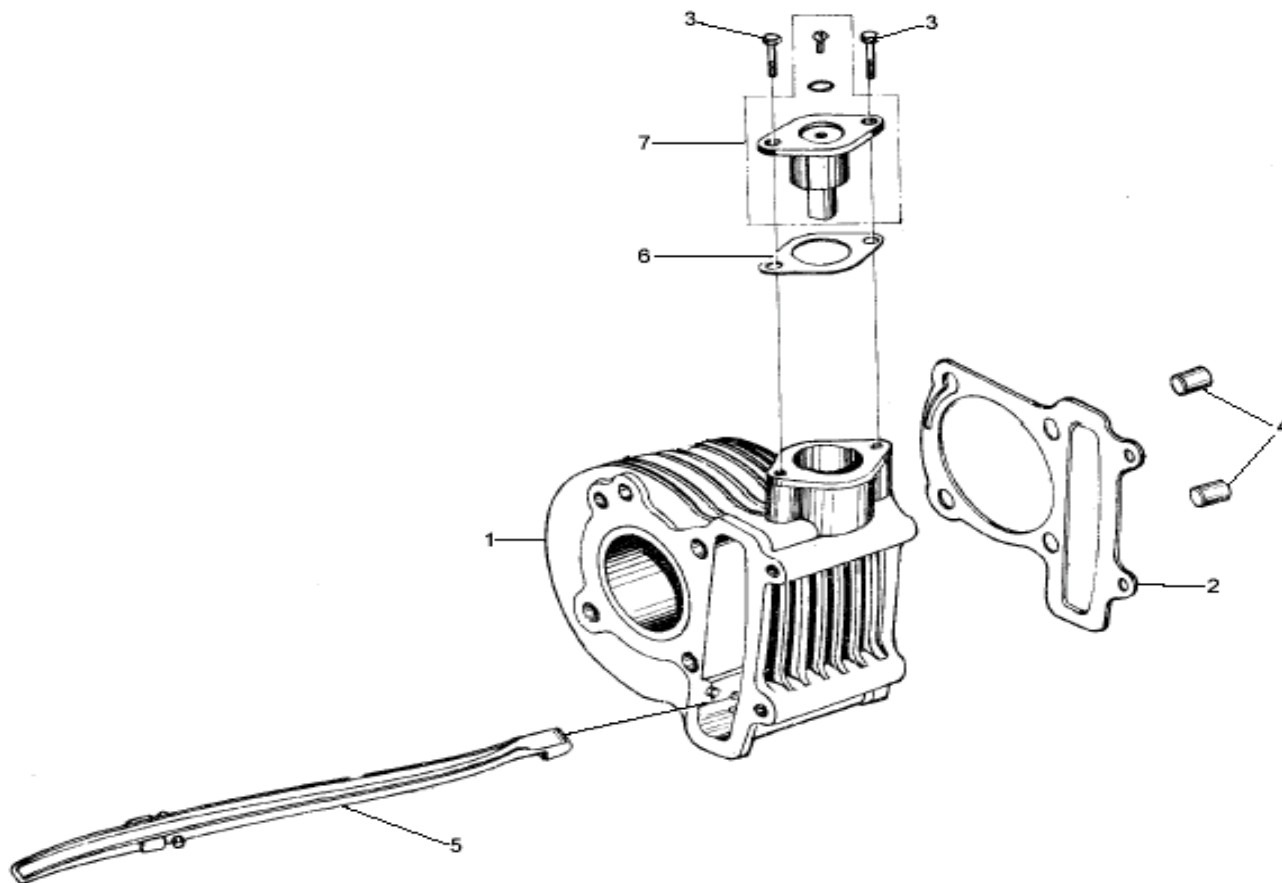

Ref#	Part#	Description	Qty
1	14317	CYLINDER - 150CC	1
2	14582	GASKET, CYLINDER BASE - 150CC	1
3	50032	BOLT FLANGE SH 6 X 22	2
4	14266	PIN, M10 X 16 DOWEL	2
5	14276	GUIDE, CAM CHAIN - 150CC	2
6	14275	GASKET, CAM CHAIN TENSIONER - 150CC	1
7	14274	ASM, CAM CHAIN TENSIONER - 150CC	1

NOTE: parts denoted as left or right hand are from driver's point of view.

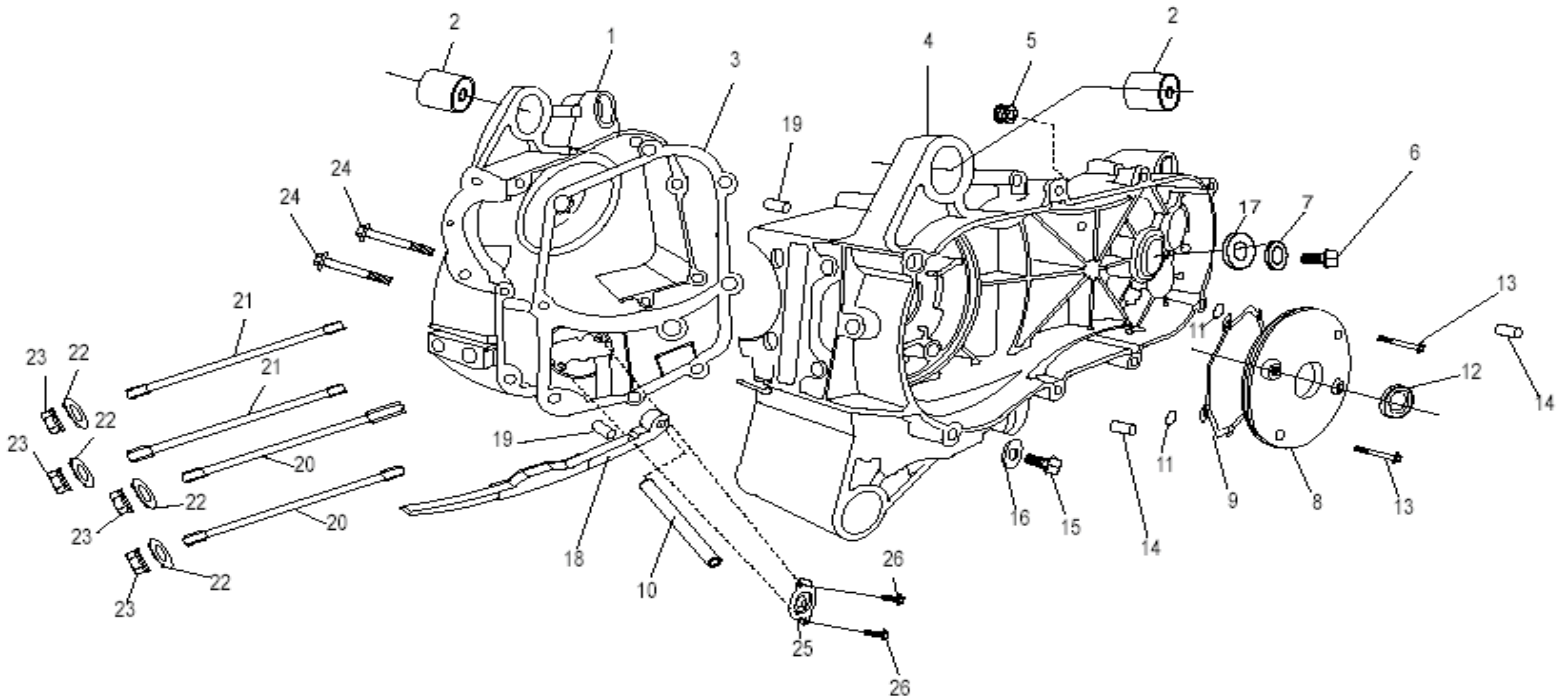

* ASW determined that it is more cost effective due to labor to replace the entire engine if this part is needed. Once this determination was made, ASW stopped ordering this part as a replacement item and are now sold out.

Ref#	Part#	Description	Qty
1	14277	(OUT OF STOCK)* HOUSING, CRANKCASE RH	1
2	14278	BUSHING, ENGINE HANGER - 150CC	2
3	14279	GASKET, CRANKCASE - 150CC	1
4	14280	HOUSING, CRANKCASE LH - 150CC	1
5	14558	GROMMET	1
6	14281	BOLT, M10 X 1.25 X 15 FHCS ZN	1
7	14282	WASHER, M10.2 X 18 X 1.3 FLAT	1
8	14283	COVER, SMALL LEFT - 150CC	1
9	14284	O-RING, M108 X 2	1
10	14559	PIN	1
11	14285	O-RING, M6 X 1.8	2
12	50104	OIL SEAL 19.8 X 30 X 5	1
13	14286	BOLT, M6 X 1.00 X 18 FHCS ZN	4

Ref#	Part#	Description	Qty
14	14287	PIN, M10 X 14 DOWEL	2
15	14288	BOLT, M12 X 1.5 SPECIAL - 150CC	1
16	14289	WASHER, M12 FLAT ZN	2
17	14290	SEAL, M20 X 32 X 6	2
18	14883	TENSIONER, CAM CHAIN - 150CC	1
19	50016	PIN DOWEL SPECIAL 8 X 14	2
20	14291	STUD, M8 X 1.25 X 195.5	2
21	14292	STUD, M8 X 1.25 X 187.5	2
22	14293	WASHER, M8 FLAT ZN	4
23	14294	NUT, M8 X 1.25 FLANGE HEAD	4
24	14295	BOLT, M6 X 1.00 X 50 FHCS ZN	2
25	14501	SPACER, OIL - 150CC	1
26	14296	BOLT, M6 X 1.00 X 12 FHCS ZN	2

NOTE: parts denoted as left or right hand are from driver's point of view.

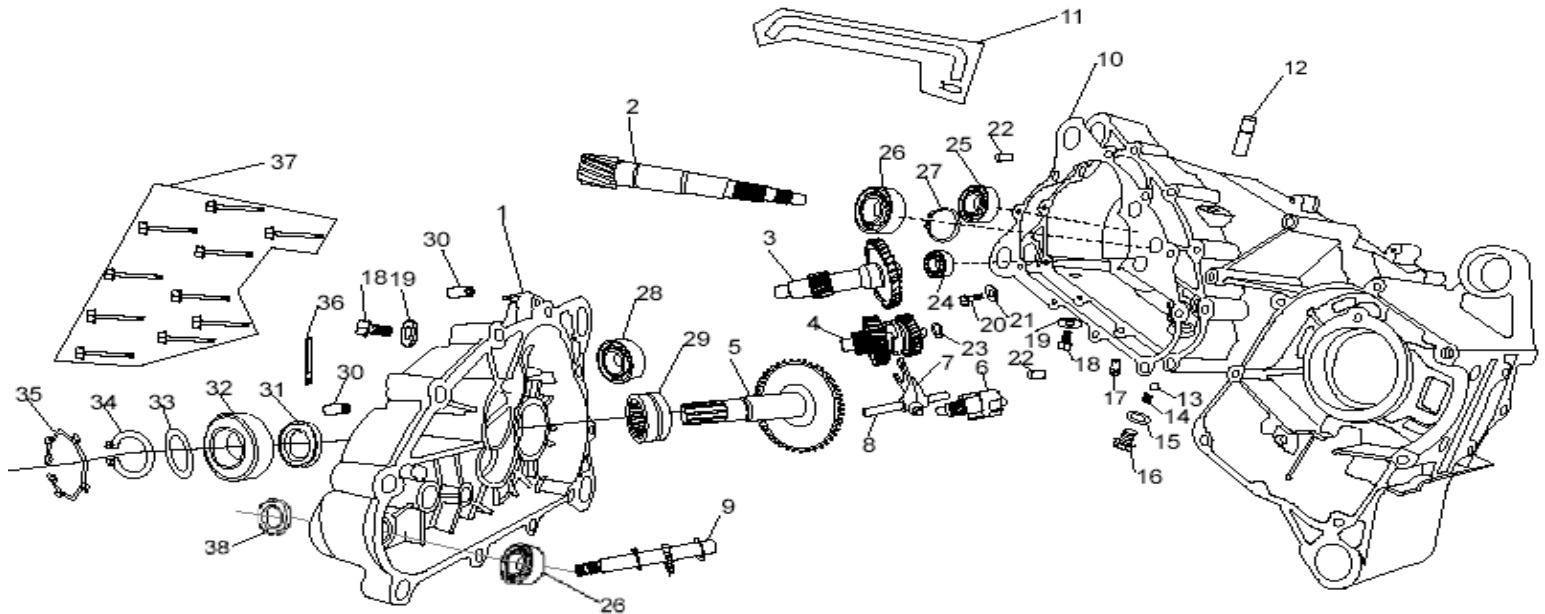

Ref#	Part#	Description	Qty
1	14297	HOUSING, OUTER TRANSMISSION - 150CC	1
2	14298	GEAR, PRI DRIVE - 150CC	1
3	14299	GEAR, SEC DRIVE - 150CC	1
4	14300	ASM, SHIFT GEAR CLUSTER D/N/R - 150CC	1
5	14841	GEAR, FINAL DRIVE SHAFT - EXT - 200S	1
6	14302	ASM, SHIFT SELECTOR - 150CC	1
7	14303	PAWL, SHIFT SELECTOR - 150CC	1
8	14304	ROD, SHIFT PAWL - 150CC	1
9	14305	SHAFT, SHIFTER CAM - 150CC	1
10	14306	GASKET, TRANSMISSION CASE - 150CC	1
11	14307	TUBE, TRANSMISSION VENT - 150CC	1
12	14308	NIPPLE, VENT TUBE - 150CC LARGE	1
13	14309	BALL, SHIFT INDENT - 150CC	1
14	14310	SPRING, SHIFT INDENT - 150CC	1
15	14311	GASKET, SHIFT INDENT - 150CC	1
16	14312	BOLT, SHIFT INDENT - 150CC	1
17	14502	NIPPLE, VENT TUBE - 150CC SMALL	1
18	14313	BOLT, DRAIN/FILL PLUG - 150CC	2
19	14314	GASKET, TRANS DRAIN PLUG - 150CC	2

Ref#	Part#	Description	Qty
20	14296	BOLT, M6 X 1.00 X 12 FHCS ZN	2
21	14315	WASHER, M6 FLAT	2
22	14287	PIN, M10 X 14 DOWEL	2
23	14316	SPACER, M15 INNER GEAR - 150CC	1
24	14149	BEARING, OUTER - 6202-Z	1
25	50102	BEARING BALL RADIAL 6203	1
26	14146	BEARING, INNER - 6204-Z	1
27	14106	CIRCLIP, M20	1
28	14503	BEARING, 6302 15 X 42 X 13	1
29	14504	BEARING, RNA4905 30 X 42 X 17	1
30	14505	BUSHING, SHOCK ABSORBING - 150CC	2
31	14318	SEAL, M30 X 40 X 6	1
32	14598	BEARING, SEALED 6205 - 150CC	1
33	14511	WASHER, M22 X 31 X 2.5 FLAT	1
34	14319	CIRCLIP, M25	1
35	14320	CIRCLIP, M52	1
36	14321	CLAMP, WIRE - 150CC	1
37	14235	BOLT, M6 X 1.00 X 40 FHCS ZN	10
38	14597	OIL SEAL, SHIFTER CAM - 150CC	1

NOTE: parts denoted as left or right hand are from driver's point of view.

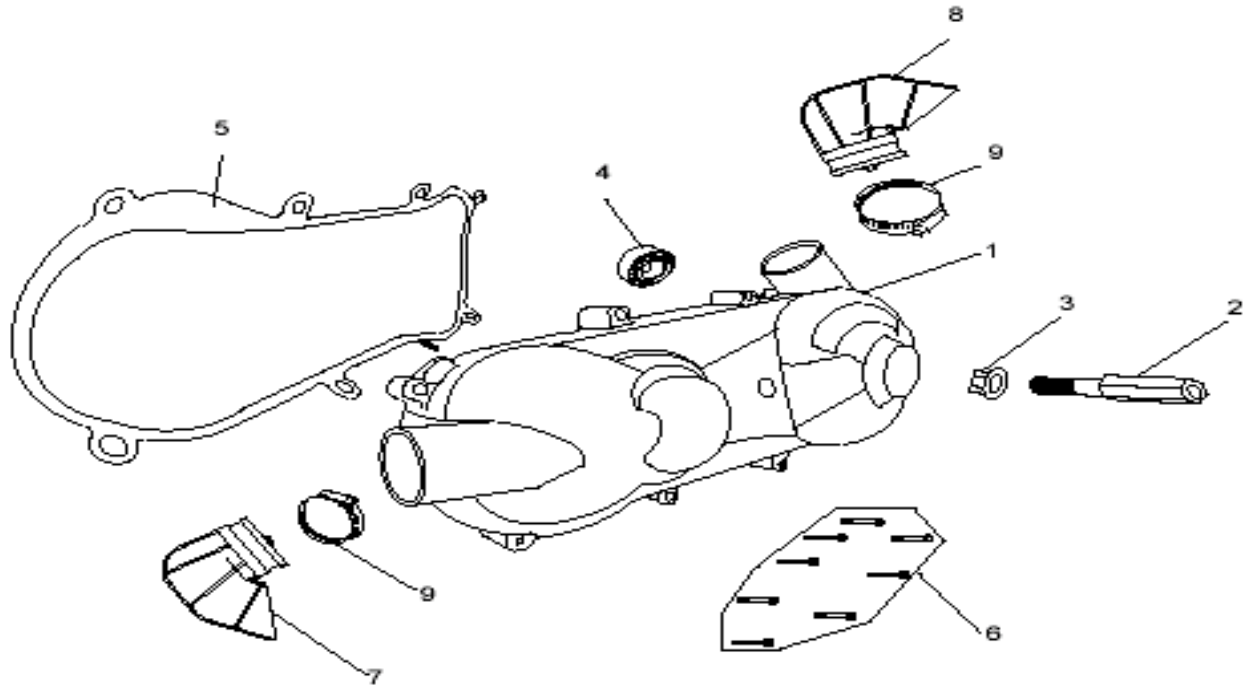

Ref#	Part#	Description	Qty
1	14323	COVER, CVT - 150CC	1
2	14507	BRACKET, EXHAUST - 150CC	1
3	14324	NUT, M12 X 1.25 LOCKING FLANGE ZN	1
4	14508	BEARING, 6200 10 X 30 X 9	2
5	14325	GASKET, CVT COVER - 150CC	1
6	14235	BOLT, M6 X 1.00 X 40 FHCS ZN	8
7	14322	SNORKEL, CVT - 150CC	1
8	14322	SNORKEL, CVT - 150CC	1
9	14509	CLAMP, SNORKEL - 150CC	2

NOTE: parts denoted as left or right hand are from driver's point of view.

6152 SECTION 6 OUTER CRANKCASE ASSEMBLY

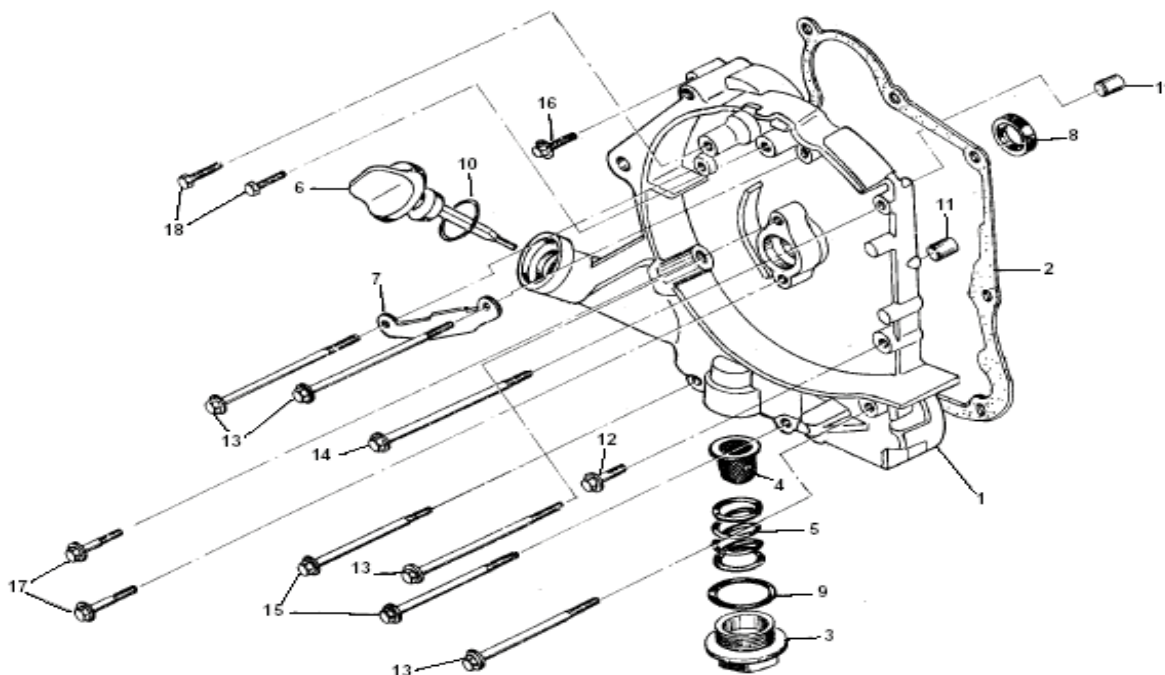

Ref#	Part#	Description	Qty
1	14326	COVER, OUTER CRANKCASE RH - 150CC	1
2	14327	GASKET, OUTER CRANKCASE - 150CC	1
3	14328	CAP, OIL DRAIN - 150CC	1
4	14329	SCREEN, OIL FILTER - 150CC	1
5	14330	SPRING, OIL FILTER SCREEN - 150CC	1
6	14331	DIPSTICK, OIL FILL - 150CC	1
7	14332	CLAMP, AC GENERATOR - 150CC	1
8	14333	SEAL, M19.8 X 30 X 5 OIL	1
9	14334	O-RING, M30.8 X 3	1

Ref#	Part#	Description	Qty
10	14335	O-RING, M18 X 3	1
11	50016	PIN DOWEL SPECIAL 8 X 14	2
12	14336	BOLT, M6 X 1.00 X 28 FHCS ZN	1
13	14337	BOLT, M6 X 1.00 X 95 FHCS ZN	4
14	14338	BOLT, M6 X 1.00 X 100 FHCS ZN	1
15	14339	BOLT, M6 X 1.00 X 110 FHCS ZN	2
16	14340	BOLT, M6 X 1.00 X 35 FHCS ZN	1
17	14341	BOLT, M6 X 1.00 X 20 FHCS ZN	2
18	14296	BOLT, M6 X 1.00 X 12 FHCS ZN	2

NOTE: parts denoted as left or right hand are from driver's point of view.

6152 SECTION 7 PISTON, CRANK & CONNECTING ROD

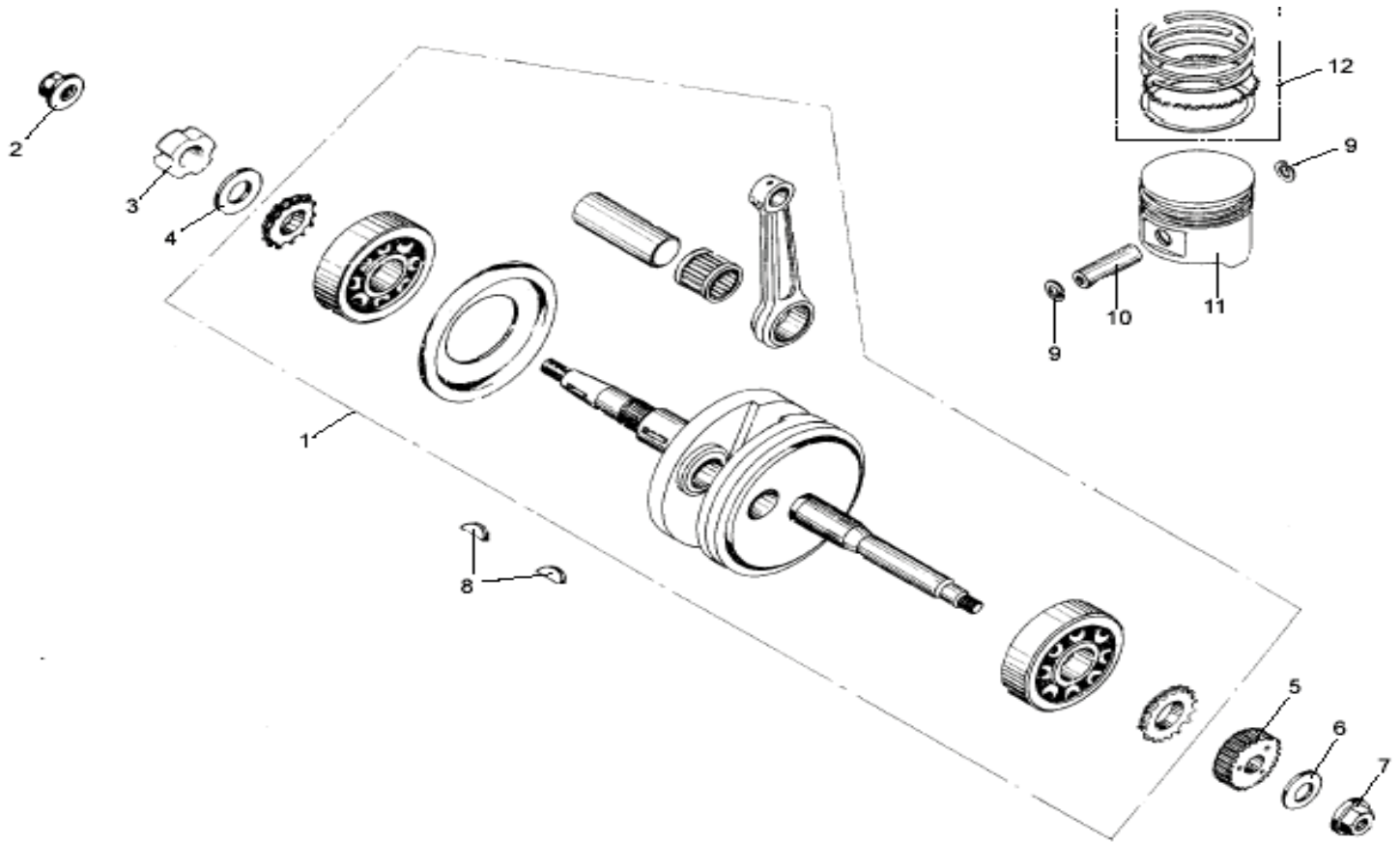

Ref#	Part#	Description	Qty
1	14342	ASM, CRANK - CON ROD - 150CC	1
2	14324	NUT, M12 X 1.25 LOCKING FLANGE ZN	1
3	14510	NUT, M22 X 1.00 SPANNING - 150CC	1
4	14511	WASHER, M22 X 31 X 2.5 FLAT	1
5	14344	GEAR, KICK DRIVE - 150CC	1
6	14289	WASHER, M12 FLAT ZN	1
7	14324	NUT, M12 X 1.25 LOCKING FLANGE ZN	1
8	14512	KEY, WOODRUFF M4 X 14	1
9	14345	CLIP, PISTON RETAINING - 150CC	2
10	14346	PIN, PISTON WRIST - 150CC	1
11	14347	PISTON - 150CC	1
12	14348	KIT, PISTON RING - 150CC	1

NOTE: parts denoted as left or right hand are from driver's point of view.

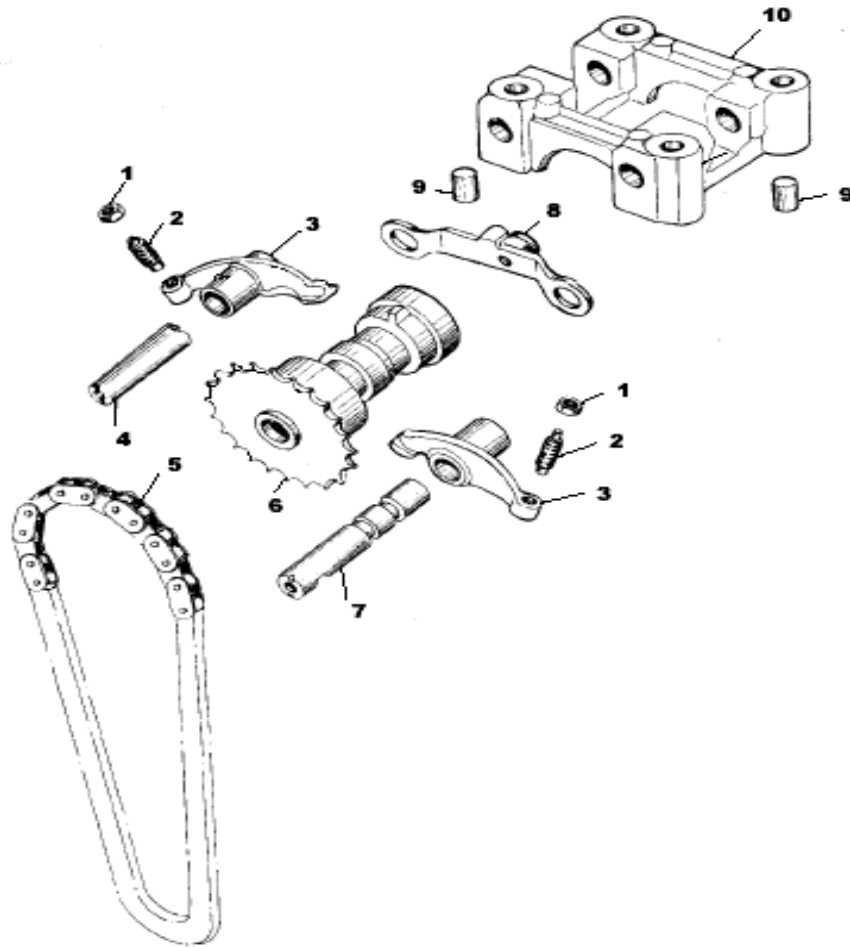

Ref#	Part#	Description	Qty
1	14513	NUT, M5 X 0.5 HEX	2
2	14349	SCREW, TAPPET ADJ - 150CC	2
3	14350	ARM, VALVE ROCKER - 150CC	2
4	14351	SHAFT, EXHAUST ROCKER ARM - 150CC	1
5	14352	CHAIN, CAMSHAFT - 150CC	1
6	14353	CAMSHAFT - 150CC	1
7	14354	SHAFT, INTAKE ROCKER ARM - 150CC	1
8	14355	PLATE, STOP - 150CC	1
9	14266	PIN, M10 X 16 DOWEL	2
10	14356	CAP, CAMSHAFT BRG - 150CC	1

NOTE: parts denoted as left or right hand are from driver's point of view.

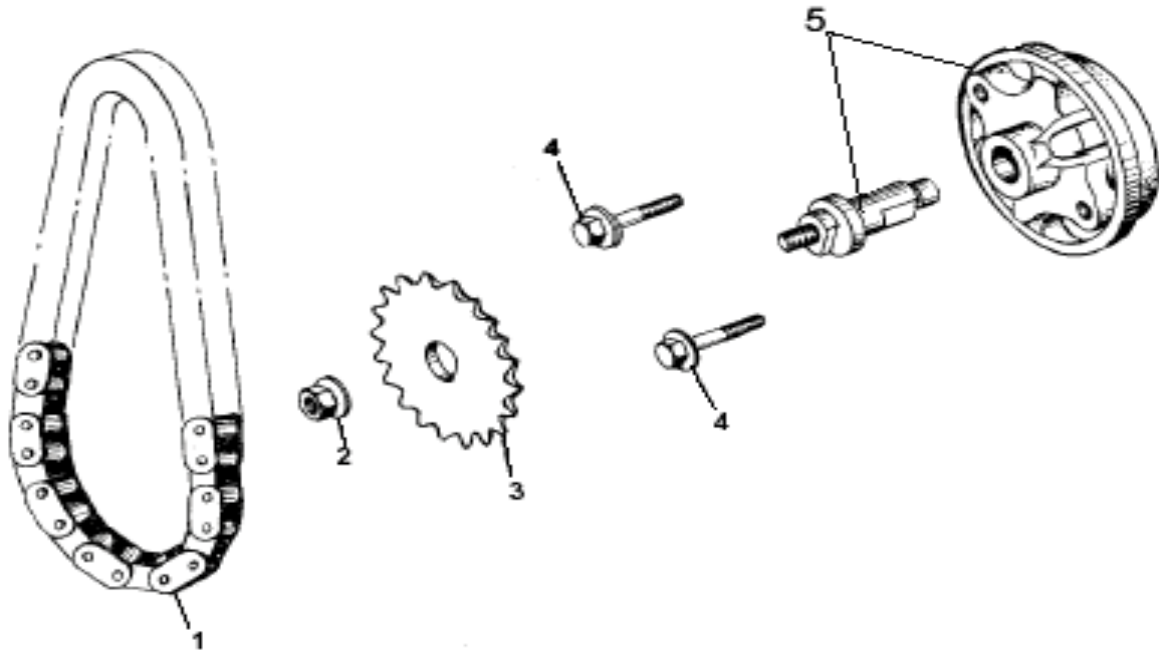

Ref#	Part#	Description	Qty
1	14357	CHAIN, OIL PUMP - 150CC	1
2	14358	NUT, M6 X 1.00 HEX FLANGE	1
3	14359	SPROCKET, OIL PUMP - 150CC	1
4	14360	BOLT, M6 X 1.00 X 30 FHCS ZN	2
5	14361	ASM, OIL PUMP - 150CC	1

NOTE: parts denoted as left or right hand are from driver's point of view.

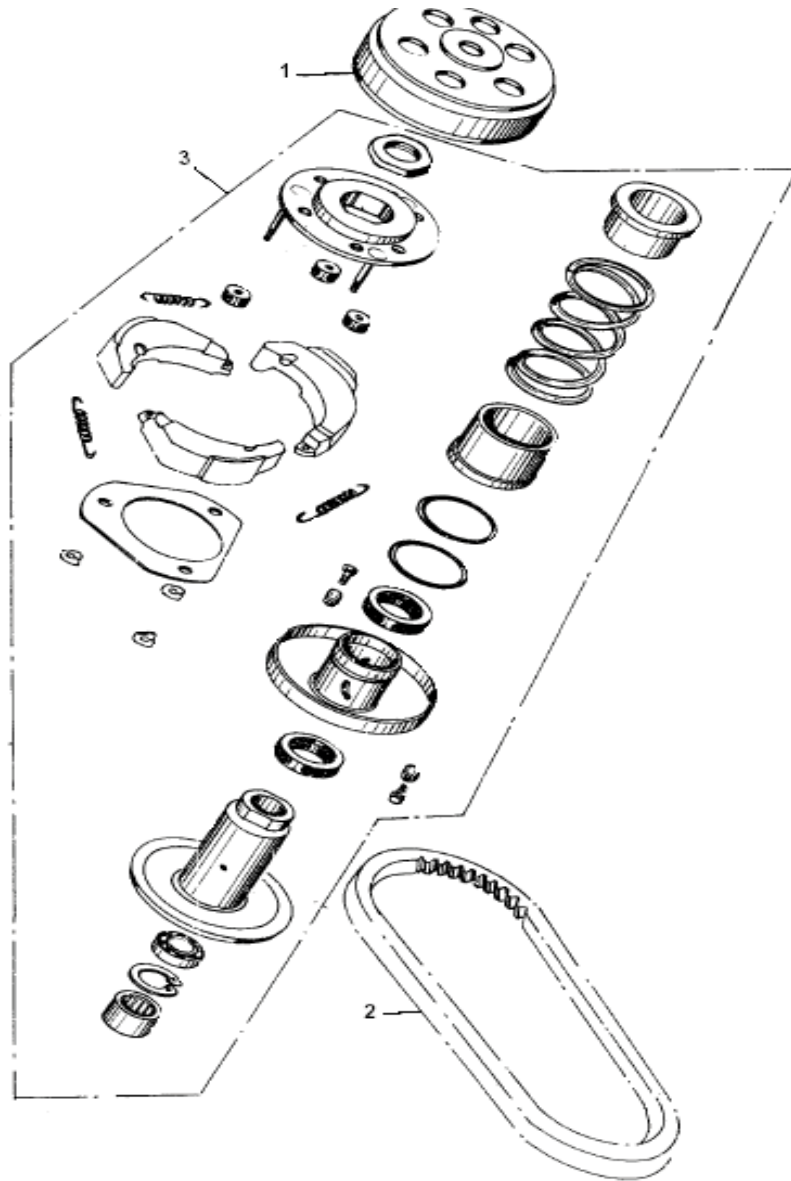

Ref#	Part#	Description	Qty
1	14362	ASM, OUTER CLUTCH - 150CC	1
2	14363	BELT, CVT - 150CC	1
3	14364	ASM, DRIVEN PULLEY - 150CC	1
4	15164	NUT, M12X1.25 LF THIN	1

NOTE: parts denoted as left or right hand are from driver's point of view.

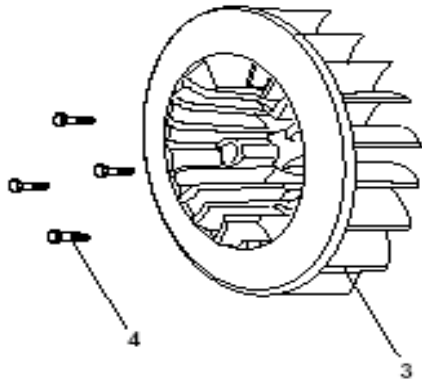
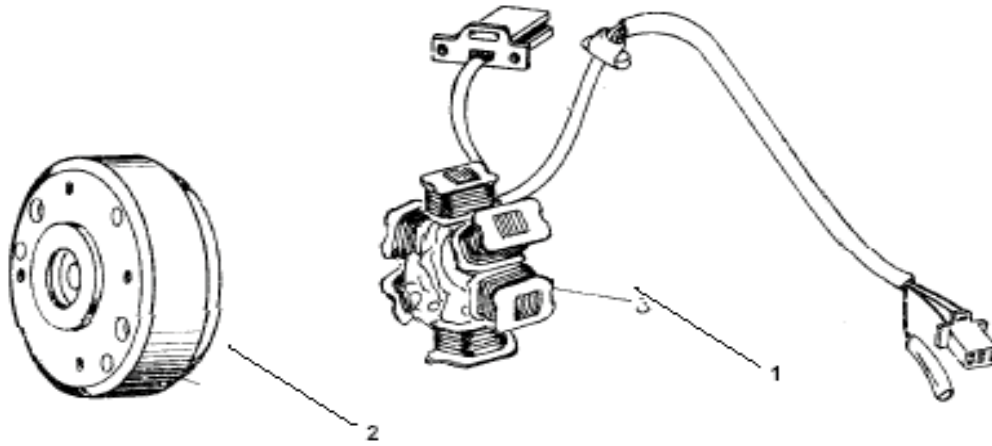

Ref#	Part#	Description	Qty
1	14365	MAGNETO - 150CC	1
2	14366	FLYWHEEL - 150CC	1
3	14367	FAN, COOLING - 150CC	1
4	14368	BOLT, M6 X 1.00 X 15 FHCS ZN	4

NOTE: parts denoted as left or right hand are from driver's point of view.

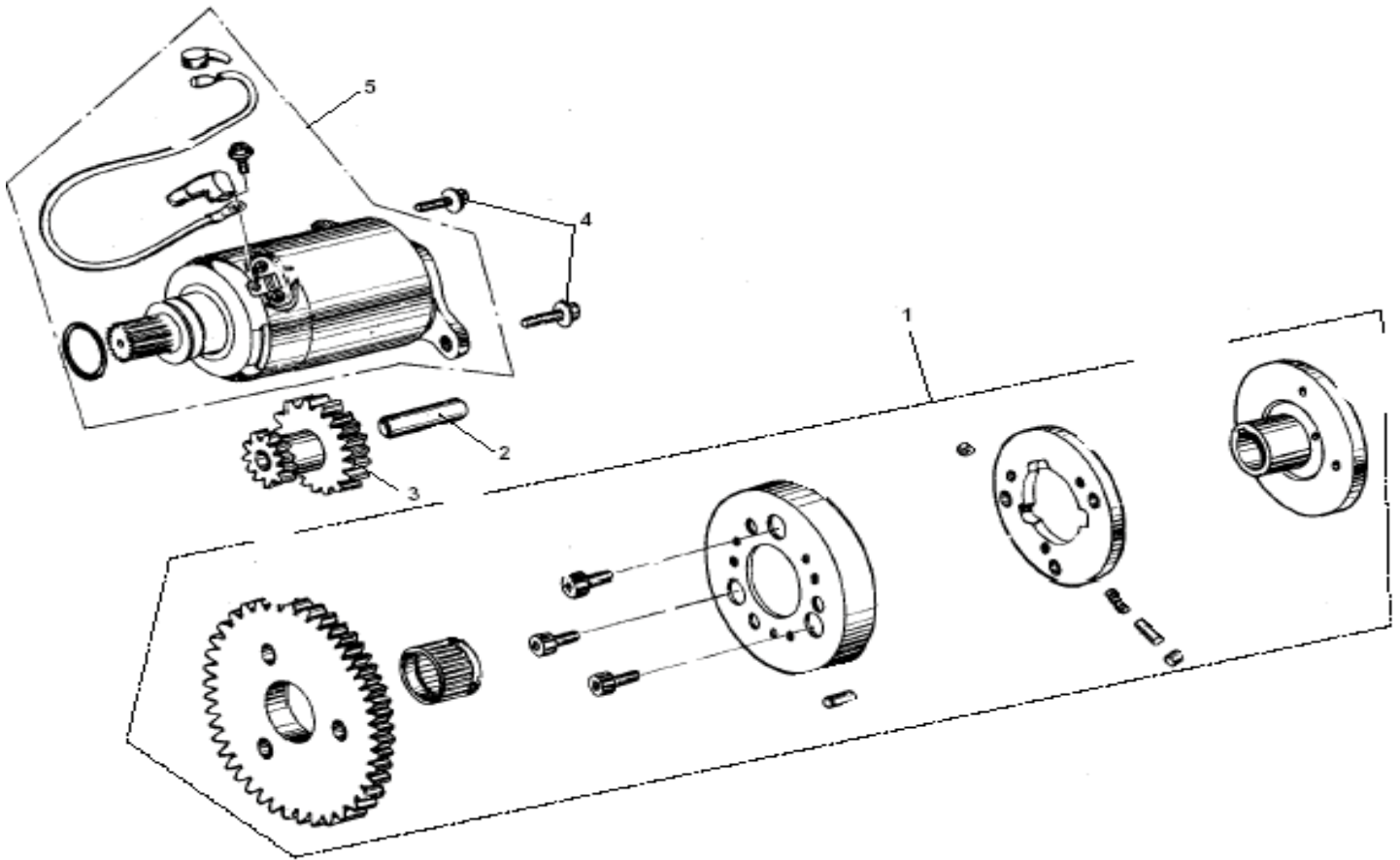

Ref#	Part#	Description	Qty
1	14369	ASM, STARTER CLUTCH - 150CC	1
2	14370	SHAFT, STARTER RED - 150CC	1
3	14371	GEAR, STARTER RED - 150CC	1
4	14372	BOLT, M6 X 1.00 X 16 FHCS ZN	2
5	14373	ASM, STARTER MOTOR - 150CC	1

NOTE: parts denoted as left or right hand are from driver's point of view.

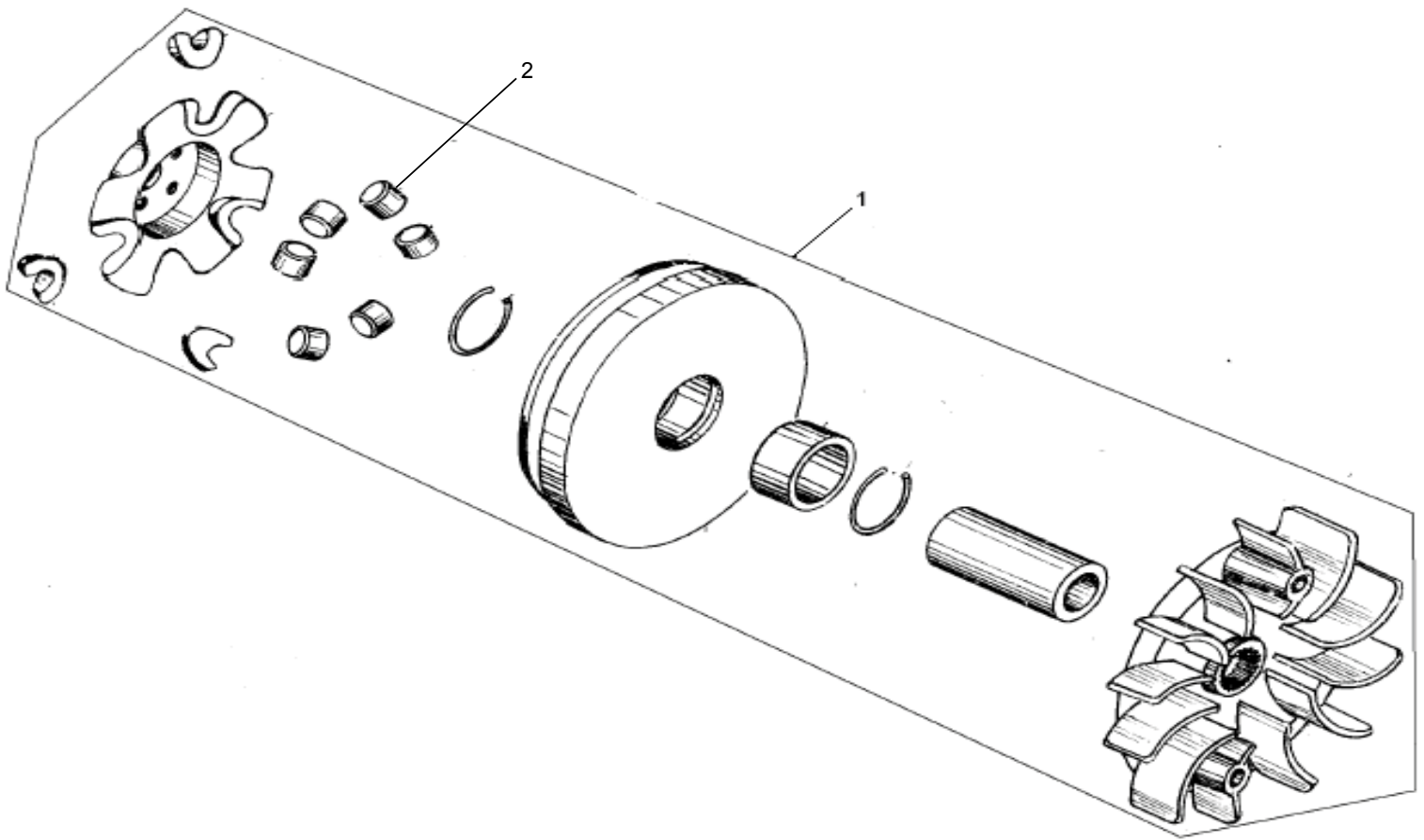

Ref#	Part#	Description	Qty
1	14374	ASM, DRIVER PULLEY - 150CC	1
2	14375	WEIGHT, DRIVER PULLEY - 150CC	6

NOTE: parts denoted as left or right hand are from driver's point of view.

6152 SECTION 14 FAN COVER & SHROUD ASSEMBLY

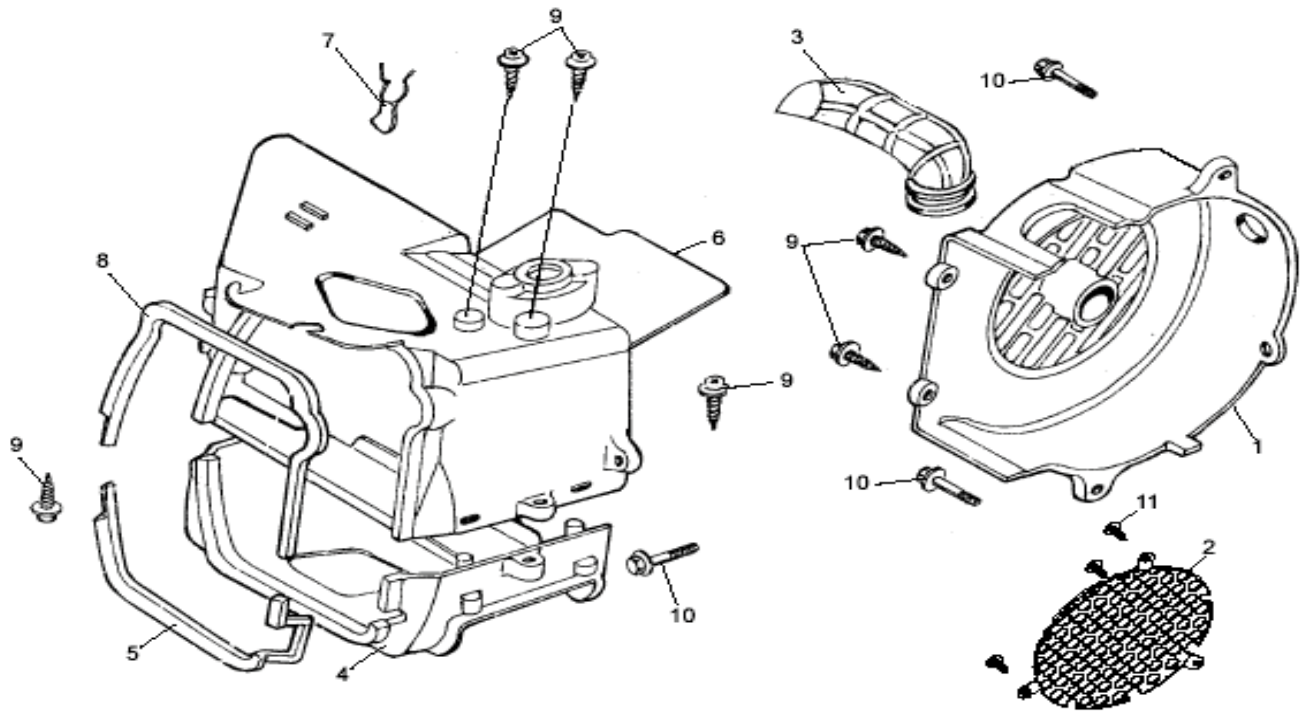

Ref#	Part#	Description	Qty
1	14540	COVER, FAN COMP - 150CC	1
2	14541	COVER, DUST - 150CC	1
3	14542	DUCT, CARBURETOR COOLING - 150CC	1
4	14543	SHROUD, LOWER - 150CC	1
5	14544	SEAL, LOWER SHROUD - 150CC	1
6	14545	SHROUD, UPPER - 150CC	1
7	14546	CLIP, CORD - 150CC	1
8	14547	SEAL, UPPER SHROUD - 150CC	1
9	50065	SCREW TAPPING	6
10	14286	BOLT FLANGE SH 6 X 18	3
11	14539	SCREW, 3.5 X 13 STFH	3

NOTE: parts denoted as left or right hand are from driver's point of view.

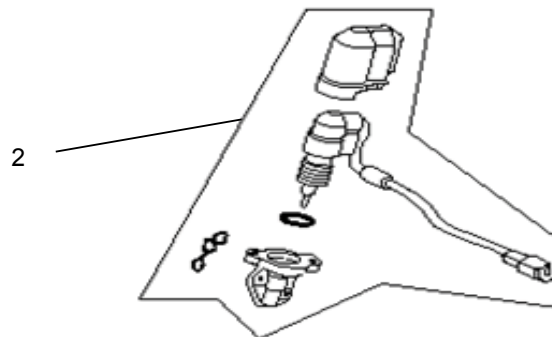
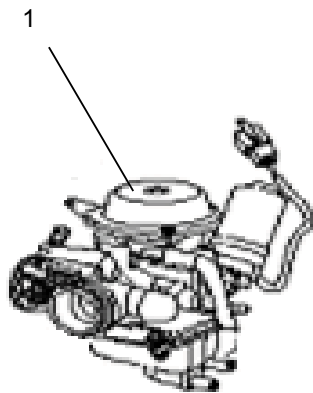

Ref#	Part#	Description	Qty
6152	14925	ASM, CARBURETOR 150CC	1
2	14924	ASM, AUTOCHOKE	1

NOTE: parts denoted as left or right hand are from driver's point of view.

6152 SECTION 16 FRAME GROUP / WARNING LABELS

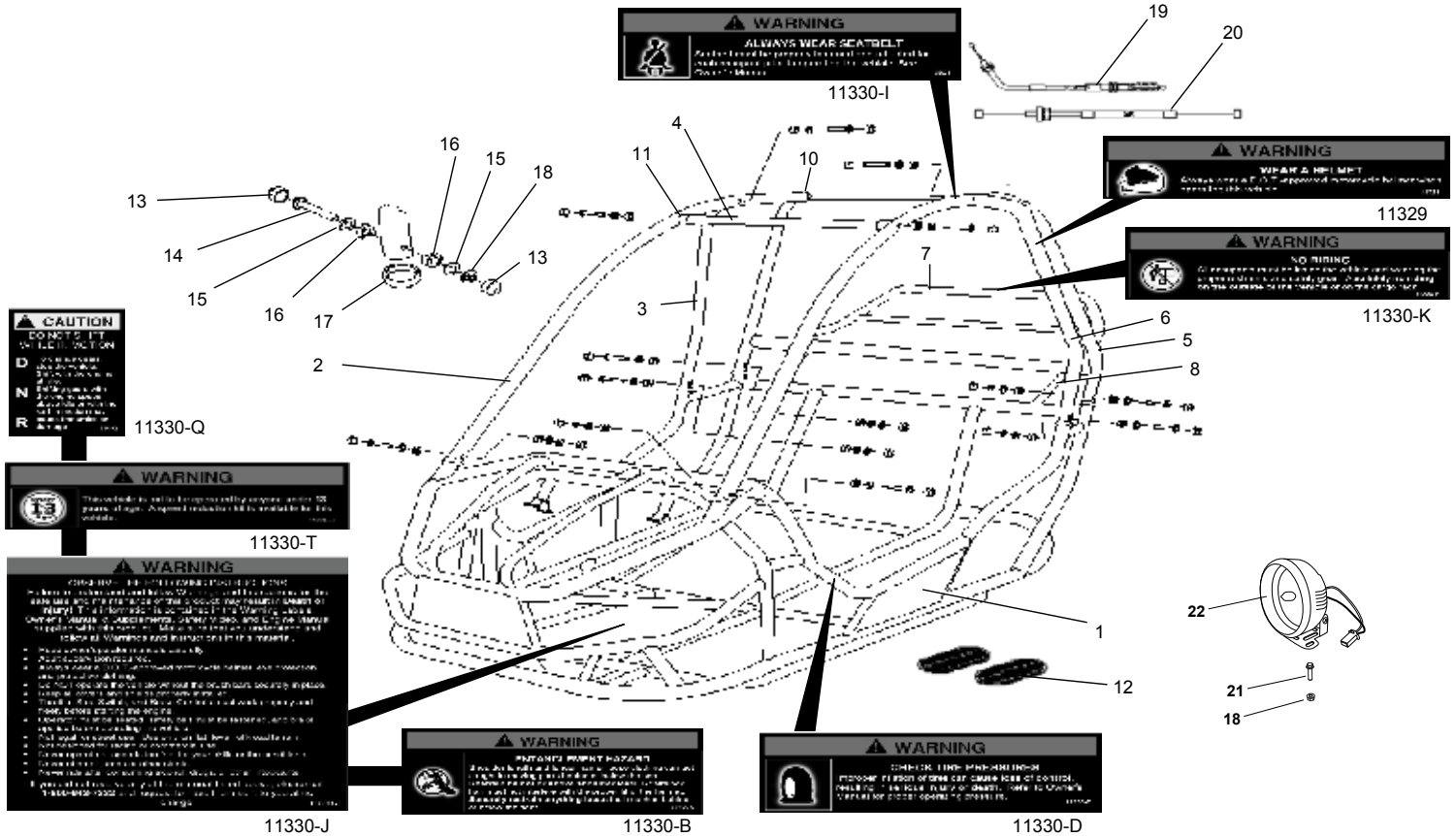

Ref#	Part#	Description	Qty
1	15000-47	FRAME, 6151 - SILVER	1
2	15001-48	BAR, A PILLAR - 6152 - CHAR	2
3	15002-48	BAR, B PILLAR RH - 6152 - CHAR	1
4	15003-48	BAR, OH CROSS - 6152 - CHAR	1
5	15004-47	BAR, C PILLAR - 6152 - SILVER	1
6	15005-48	BAR, B PILLAR LH - 6152 - CHAR	1
7	15006-47	SPOILER, REAR - 6152 - SILVER	1
8	15007-47	ARM, SPOILER SPPT - 6152 - SILVER	2
9	14091	PAD, FOAM B PILLAR W/WRAP (NOT SHOWN)	2
10	14083	ENDCAP, BAR - 1.25 BLACK PLASTIC	6
11	14084	ENDCAP, BAR - 1.00 BLACK PLASTIC	2

Ref#	Part#	Description	Qty
12	14092	PAD, RUBER FOOT - 7150	4
13	14946	COVER, BOLT CAP - 1.25	20
14	14086	BOLT, M8 X 1.25 X 55 FHCS ZN	14
15	14944	WASHER, BAR CONNECTION	20
16	14087	WASHER, 8M CONCAVE CLAMP DAC	20
17	14942	SEAL, BAR CONNECTION - 1.25	6
18	14088	NUT, M8 X 1.25 LOCKING FLANGE DAC	8
19	14456	CABLE, D/N/R SHIFT - 150CC	2
20	14094	CABLE, THROTTLE - 6150/7150	1
21	15955	BOLT, M8 X 1.25 X 16 HHCS	2
22	15086	LIGHT, ROUND 3-1/2" - 25W	2

NOTE: parts denoted as left or right hand are from driver's point of view.

6152 SECTION 17 FRAME GROUP (cont.)

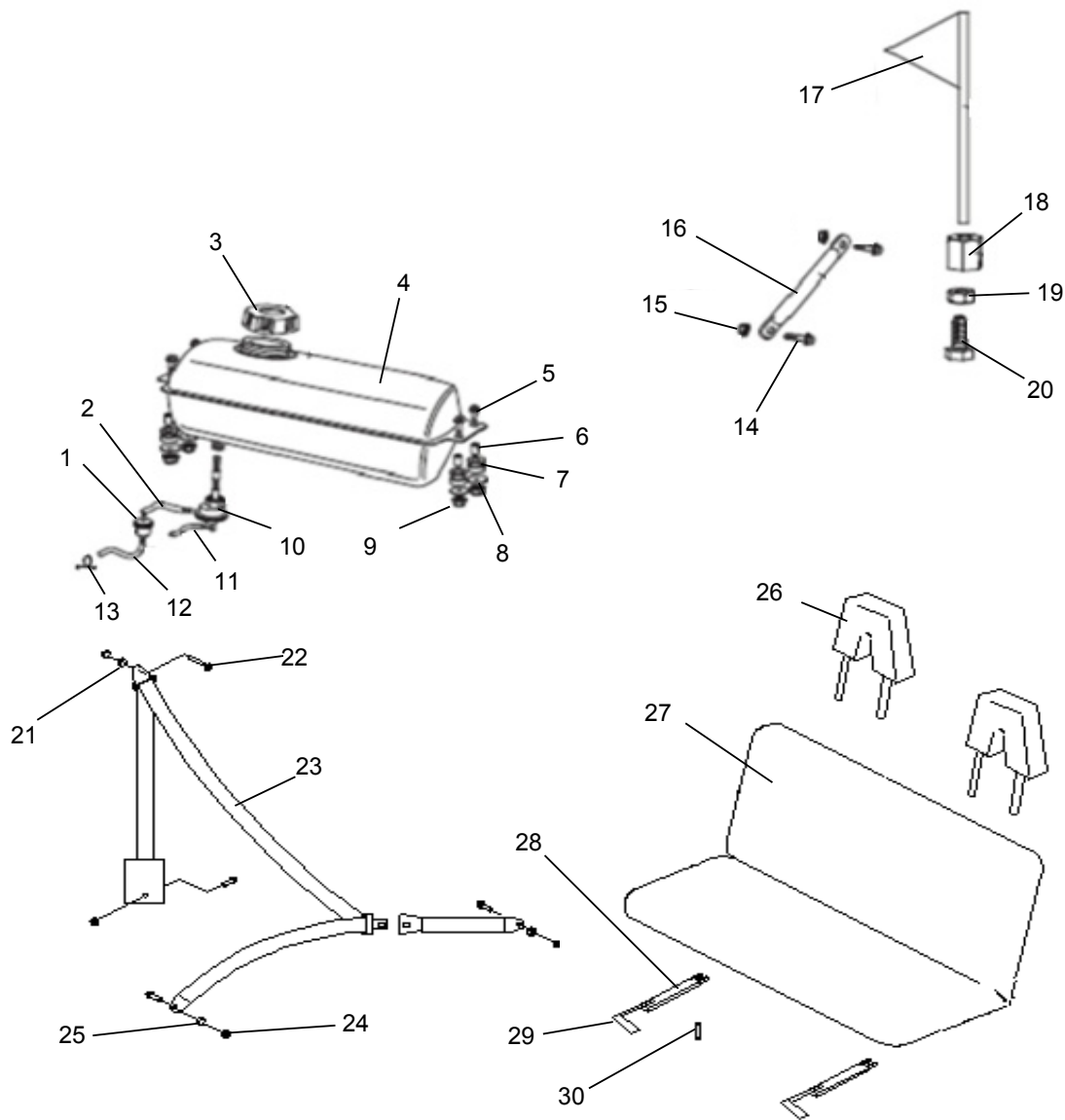

Ref#	Part#	Description	Qty
1	14167	FILTER, FUEL	1
2	14164	LINE, FUEL #1	1
3	13871	CAP, FUEL - 6150/7150	1
4	14533	TANK, FUEL - 6150 SILVER	1
5	14086	BOLT, M8 X 1.25 X 55 FHCS DAC	4
6	14162	SPACER, FUEL TANK	4
7	14163	BUSHING, FUEL TANK MOUNT	4
8	14293	WASHER, M8 FLAT	4
9	14088	NUT, M8 X 1.25 LOCKING FLANGE	4
10	50210	ASM, AUTO FUEL COCK	1
11	14165	LINE, VACUUM #1	1
12	14166	LINE, FUEL #2	1
13	80050	CLIP - 8 X 0.8	9
14	14239	BOLT, M8 X 1.25 X 20 FHCS DAC	4
15	14088	NUT, M8 X 1.25 LOCKING FLANGE	4
16	15007-47	ARM, SPOILER SPPT - 6152 - SILVER	2

Ref#	Part#	Description	Qty
17	14464	FLAG, SAFETY	1
18	14466	NUT, DECORATIVE PLASTIC FLAG MNT	1
19	14492	NUT, M12 X 1.25	1
20	14465	BOLT, M12 X 1.25 X 30 FLAG MOUNTING	1
21	14289	WASHER, M12 STEPPED SEAT BELT	2
22	14451	BOLT, M12 X 1.25 X 25 FHCS DAC	8
23	14786	RETRACTABLE SEATBELT (WITHOUT SLEEVE)	2
23	8375	SEATBELT SLEEVE (NOT ILLUSTRATED)	2
24	14324	NUT, M12 X 1.25 LOCKING FLANGE	8
25	14690	WASHER, M12 DAC	2
26	15008	HEADREST, BLK - 6151	2
27	15009	ASM, SEAT VINYL BENCH - 6151 - BLK	1
28	14171	SLIDE, SEAT (PAIR)	1
29	15254	COVER, SEAT SLIDE HANDLE (BLK)	2
30	14440	BOLT, M8 X 1.25 X 40 HHCS DAC	2

NOTE: parts denoted as left or right hand are from driver's point of view.

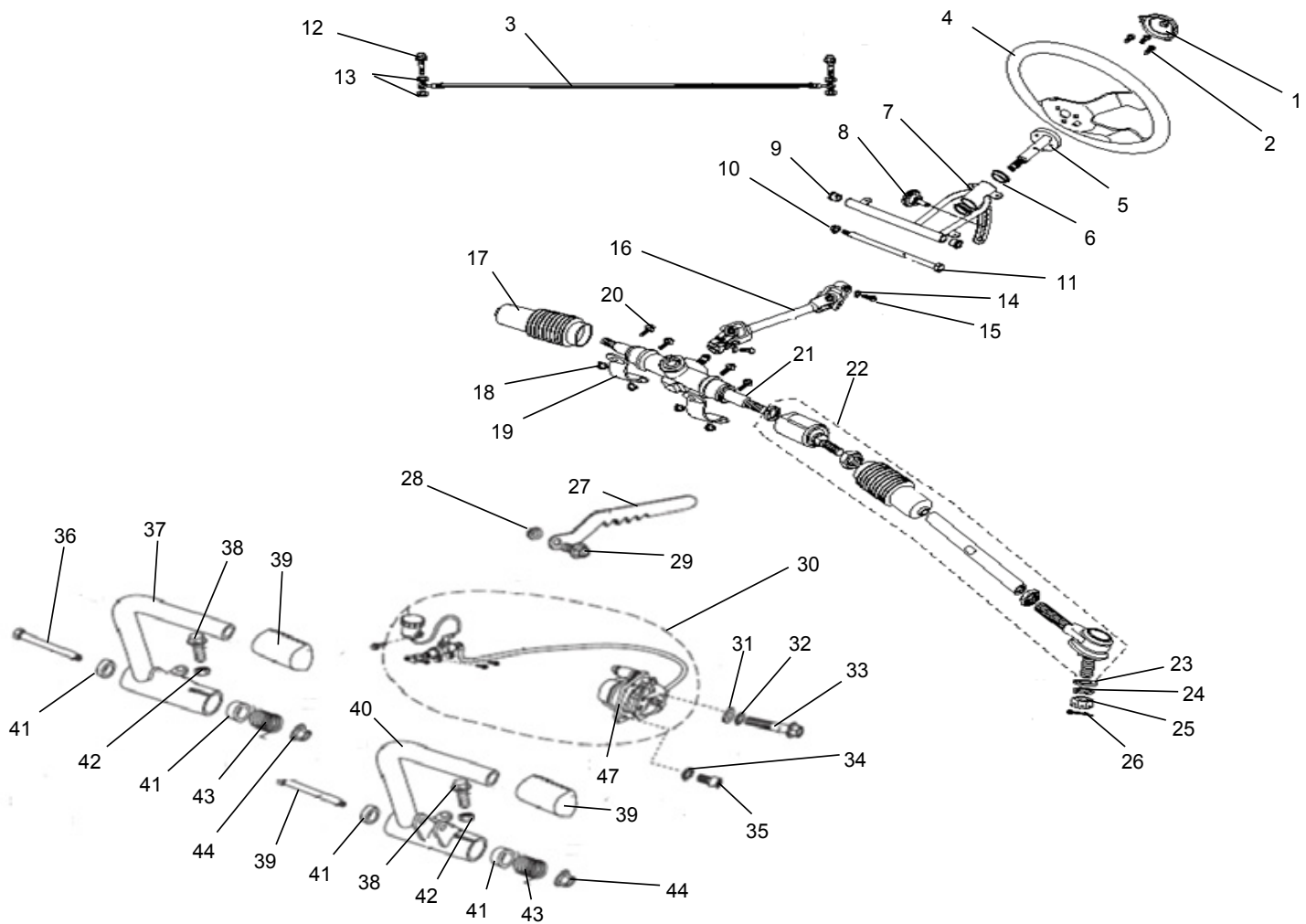

Ref#	Part#	Description	Qty
1	14100	COVER, STEERING WHEEL - 6150/7150	1
2	14237	BOLT, M6 X 1.00 X 12 HHCS DAC	3
3	14525	HOSE, BRAKE - 6150	1
4	14102	STEERING WHEEL - 6150/7150	1
5	14103	SHAFT, STEERING - 7150	1
6	14104	BUSHING, FLANGED SLEEVE 20 X 28 X 24.1	2
7	14111	BRACKET, TILT STEERING - RED - 7150	1
8	14125	KNOB, STEERING TILT - 7150	1
9	14126	BUSHING, FLANGED SLEEVE 12 X 16 X 12	2
10	14088	NUT, M8 X 1.25 LOCKING FLANGE DAC	1
11	14444	BOLT, M8 X 1.25 X 240 HHCS ZN	1
12	14460	BOLT, M10 X 24 BRAKE BANJO	2
13	14127	WASHER, BRASS BRAKE LINE	4
14	14495	WASHER, M8 SPLIT LOCK DAC	2
15	14437	BOLT, M8 X 1.25 X 25 HHCS ZN	2
16	14107	SHAFT, STEERING U-JOINT - 7150	1
17	14109	BOOT, R&P BLACK RUBBER - 7150	2
18	14088	NUT, M8 X 1.25 LOCKING FLANGE DAC	8
19	14112	BRACKET, RACK AND PINION MNT	2
20	14436	BOLT, M8 X 1.25 X 25 FHCS DAC	4
21	14108	ASM, RACK AND PINION - 7150	1
22	14459	ASM, TIE ROD END - 7150	2
23	14240	WASHER, M10 FLAT ZN	2
24	14241	WASHER, M10 SPLIT LOCK ZN	2

Ref#	Part#	Description	Qty
25	14242	NUT, M10 X 1.25 CASTLE	2
26	14110	PIN, M2 X 15 COTTER	2
27	14528	LEVER, PARKING BRAKE - 6150	1
28	14088	NUT, M8 X 1.25 LOCKING FLANGE DAC	1
29	14437	BOLT, M8 X 1.25 X 25 HHCS DAC	1
30	15012	ASM, HYD BRAKE - 6152	1
31	14293	WASHER, M8 FLAT DAC	1
32	14495	WASHER, M8 SPLIT LOCK DAC	1
33	14441	BOLT, M8 X 1.25 X 100 FHCS DAC	1
34	14748	WASHER, M8 SPLIT LOCK DAC	1
35	14455	BOLT, M8 X 1.25 X 14 SHCS DAC	1
36	15010	BOLT, M12 X 84 SHOULDER DAC	2
37	15011-47	PEDAL, THROTTLE - 6151 - SILVER	1
38	14430	BOLT, M6 X 1.00 X 25 FHCS DAC	2
39	14527	CAP, BRAKE PEDAL - 6150	2
40	14387-47	PEDAL, BRAKE - 6151 - SILVER	1
41	14119	BUSHING, SLEEVE 12 X 21 X 12	4
42	14236	NUT, M6 X 1.00 NYLOC DAC	2
43	14120	SPRING, BRAKE PEDAL - 7150	2
44	14088	NUT, M8 X 1.25 LOCKING FLANGE DAC	2
45	14412	BOOT, STEERING SHAFT BLACK RUBBER - 7150	2
46	15077	KIT, BRAKE PAD REAR	1
47	15076	ASM, BRAKE CALIPER - REAR	1

NOTE: parts denoted as left or right hand are from driver's point of view.

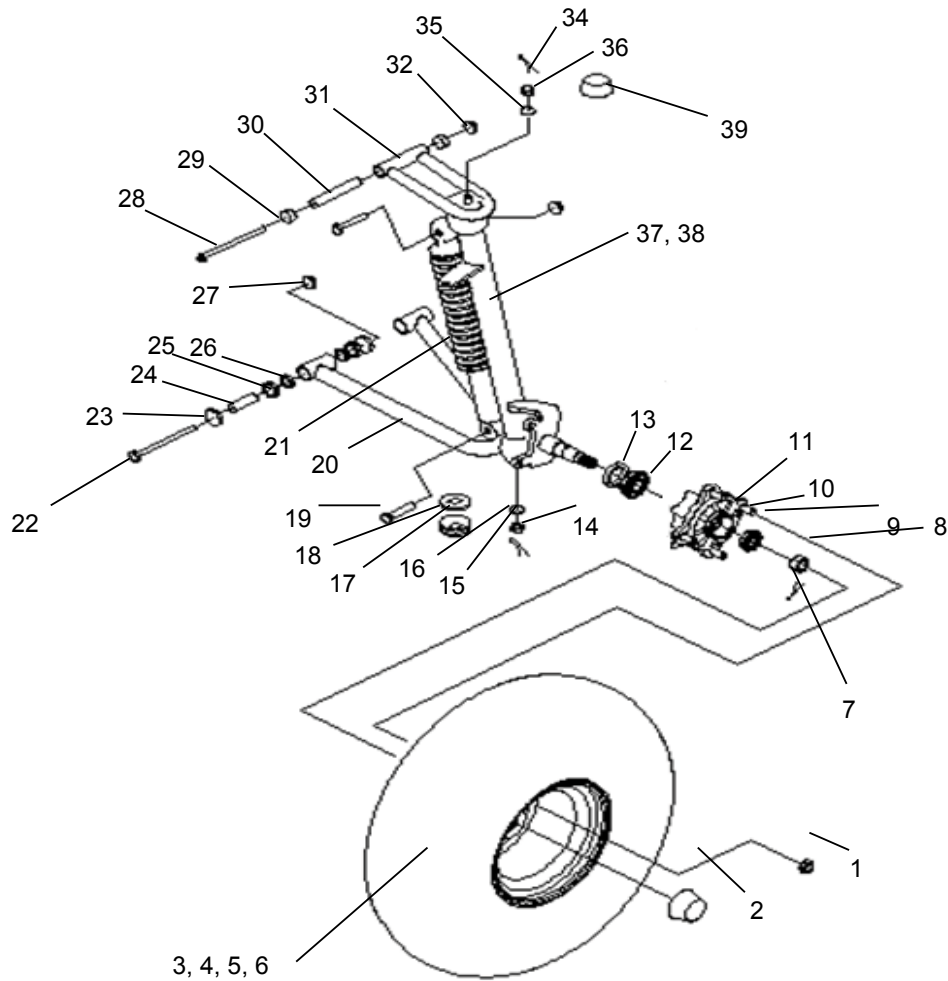

Ref#	Part#	Description	Qty
1	13979	NUT, M10 X 1.25 WF DAC	8
2	14151	CAP, HUB NOSE - BLACK RUBBER	2
3	14397	ASM, TIRE/WH FAR EAST RH - 17X7-8	1
4	14396	ASM, TIRE/WH FAR EAST LH - 17X7-8	1
5	14751	TIRE, FAR EAST 17X7-8	2
6	14755	WHEEL, 8 X 5 4-110MM, SILVER	2
7	14150	PIN, M2 X 20 COTTER	2
8	14727	NUT, M14 X 1.25 CASTLE	2
9	14149	BEARING, OUTER - 6202-Z	2
10	14147	STUD, M10 X 1.25 X 31 WHEEL	8
11	14148	HUB, FRONT WHEEL - 6150/7150	2
12	14146	BEARING, INNER - 6204-Z	2
13	14145	SEAL, M47 X 25 X 7 DUST	2
14	14490	PIN, M1.8 X 20 COTTER	4
15	14242	NUT, M10 X 1.25 CASTLE	2
16	14241	WASHER, M10 SPLIT LOCK ZN	2
17	14137	SEAL, BALL JOINT - 6150/7150	4
18	14138	SPACER, BALL JOINT HEAD - 6150/7150	4
19	14246	BOLT, M10 X 1.25 X 40 FHCS ZN	4
20	14157-47	A ARM, LOWER - SILVER W/ ZERK	2
21	14153	SHOCK, 325MM FRONT - CHR/ML/YEL - 7150	2
22	14447	BOLT, M10 X 1.25 X 80 FHCS ZN	4

Ref#	Part#	Description	Qty
23	14154	CAP, DUST - LWR SUSP ARM - 7150	8
24	14140	SPANNER, A ARM LOWER - 7150	4
25	14155	BUSHING, FLANGED SLEEVE 15 X 21 X 16	8
26	14156	O-RING, M21.2 X 2.65	8
27	14243	NUT, M10 X 1.25 LOCKING FLANGE ZN	8
28	14133	BOLT, M8 X 1.25 X 105 FHCS ZN	2
29	14126	BUSHING, FLANGED SLEEVE 12 X 16 X 12	4
30	14134	SPANNER, A ARM UPPER - 7150	2
31	14136-47	A ARM, UPPER - SILVER W/ZERK	2
32	14088	NUT, M8 X 1.25 LOCKING FLANGE ZN	2
33	14594	GREASE ZERK (NOT SHOWN)	6
34	14490	PIN, M1.8 X 20 COTTER	4
35	14245	WASHER, M12 SPLIT LOCK ZN	2
36	14244	NUT, M12 X 1.25 CASTLE DAC	8
37	15205-48	ASM, STRUT/SPINDLE LH - CHAR - 6152	1
38	15204-48	ASM, STRUT/SPINDLE RH - CHAR - 6152	1
39	14834	CAP, NUT COVER RUBBER - BLK	2
40	14243	NUT, M10 X 1.25 LOCKING FLANGE DAC	4
41	15206	FENDER, FRONT MOUNT - 6152	2
42	15207	MOUNT, FRONT FENDER RH - 6152	1
43	15208	MOUNT, FRONT FENDER LH - 6152	1

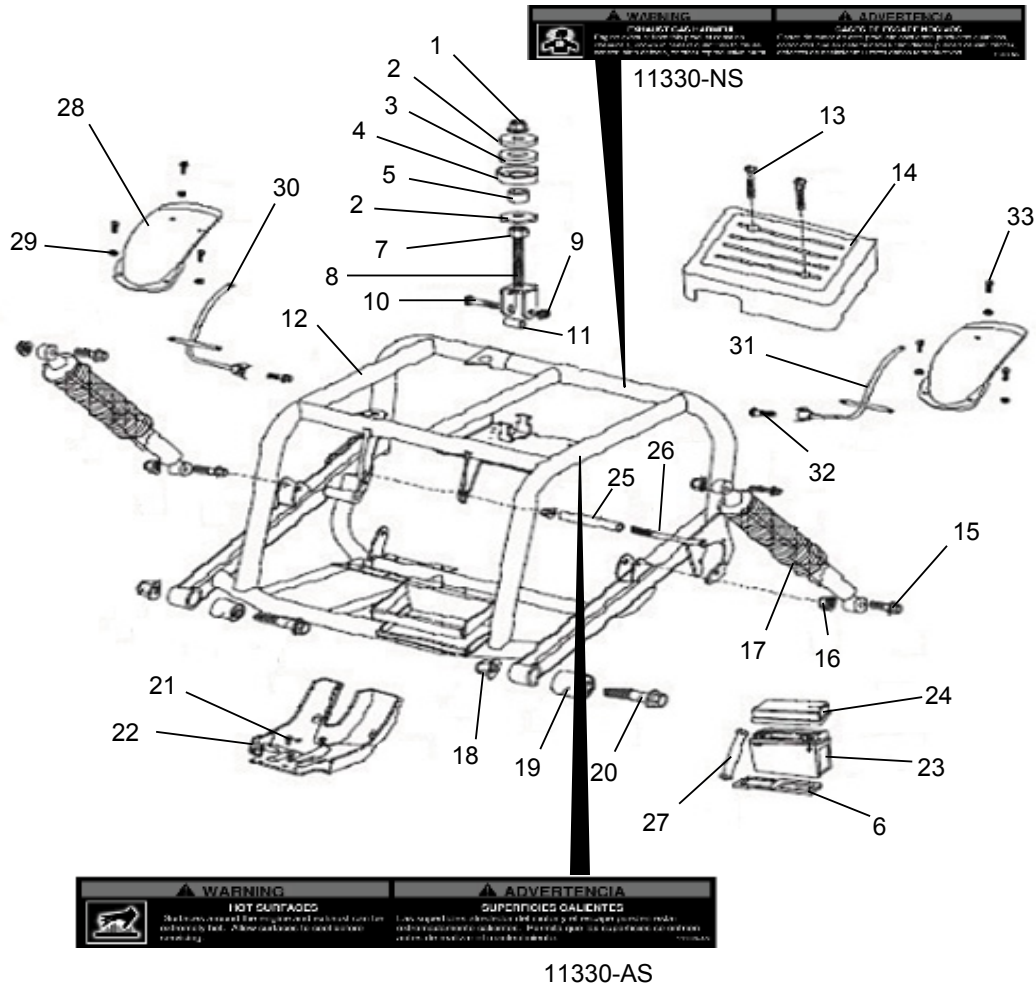

11330-AS

Ref#	Part#	Description	Qty
1	14324	NUT, M12 X 1.25 LOCKING FLANGE DAC	1
2	14289	WASHER, M12 FLAT DAC	2
3	14467	BUSHING, ENGINE ADJ ISOLATOR - 150CC	1
4	14468	SPACER, ENGINE ADJ CUP - 150CC	1
5	14469	SPACER, ENGINE ADJ ALIGNMENT - 150CC	1
6	14188	GASKET, BATTERY CAP - 150CC	1
7	14492	NUT, M12 X 1.25 HEX DAC	1
8	14470	LINK, CHAIN TENSIONING - 150CC	1
9	14243	NUT, M10 X 1.25 LOCKING FLANGE DAC	1
10	14446	BOLT, M10 X 1.25 X 45 FHCS DAC	1
11	14471	SPACER, ENGINE MOUNTING LINK - 150CC	1
12	14405-47	ASM, REAR SWINGARM - SILVER - 6150	1
13	14431	BOLT, M6 X 1.00 X 60 FHCS DAC	2
14	14172	COVER, ELECTRICAL - 6150/7150	1
15	14246	BOLT, M10 X 1.25 X 40 FHCS DAC	4
16	14243	NUT, M10 X 1.25 LOCKING FLANGE DAC	5
17	14535	SHOCK, REAR - 6150	2

Ref#	Part#	Description	Qty
18	14324	NUT, M12 X 1.25 LOCKING FLANGE DAC	2
19	14191	BUSHING, SWINGARM ISOLATOR - 150CC	2
20	14452	BOLT, M12 X 1.25 X 60 FHCS ZN	2
21	14372	BOLT, M6 X 1 X 16 FHCS DAC	4
22	14185	GUARD, LOWER CHAIN - 150CC	1
23	14189	BATTERY - GTX9-BS	1
24	14186	COVER, BATTERY - 150CC	1
25	14177	SPANNER, ENGINE MOUNT	1
26	14449	BOLT, M10 X 1.25 X 195 HHCS DAC	1
27	14187	STRAP, BATTERY HOLD DOWN - 150CC	1
28	15322	FENDER, REAR - GBLACK 10.5IN (OPTIONAL)	2
29	14236	NUT, M6 X 1.00 NYLOC FLANGE DAC	6
30	14181	BRACKET, RH REAR FENDER (OPTIONAL)	1
31	14179	BRACKET, LH REAR FENDER (OPTIONAL)	1
32	14247	BOLT, M8 X 1.25 X 45 FHCS DAC	2
33	14820	BOLT, M6 X 1.00 X 14 FHCS SS	6

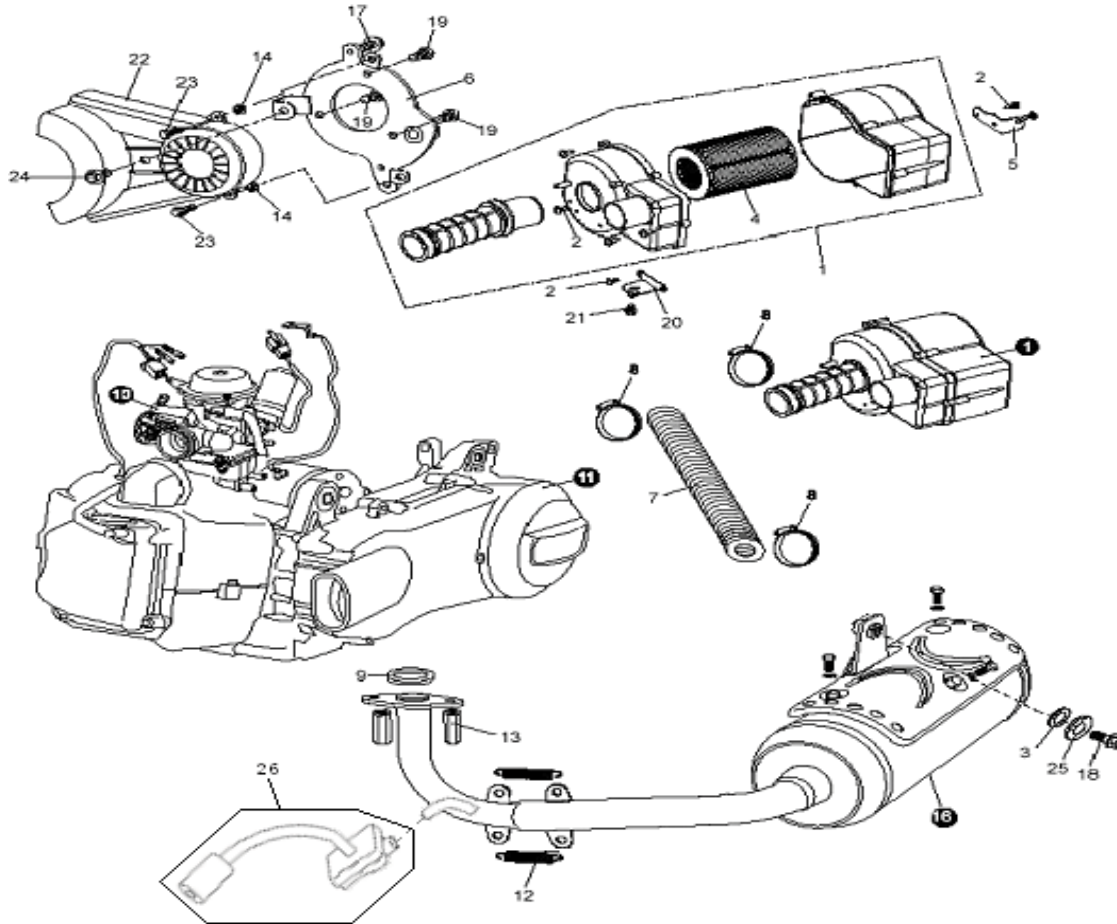

Ref#	Part#	Description	Qty
1	14192	ASM, AIR CLEANER - 150CC	1
2	14423	SCREW, M5 X 16 PHSM ZN	9
3	14495	WASHER, M8 SPLIT LOCK ZN	1
4	14194	FILTER, AIR - 150CC	1
5	14201	BRACKET, #2 AIR CLEANER MNT - 6150/7150	1
6	14480	BRACKET, REAR ENG MOUNT - 150CC	1
7	14195	HOSE, AIR INTAKE - 150CC	1
8	14481	CLAMP, HOSE 45MM	3
9	14196	GASKET, EX PIPE - 150CC	1
10	14925	ASM, CARBURETOR 150CC	1
11	14198	ASM, ENGINE - 6150	1
12	14482	SPRING, EXHAUST PIPE - 150CC	2
13	50050	NUT (HEX) CAP M6	2

Ref#	Part#	Description	Qty
14	14236	NUT, M6 X 1.00 NYLOC FLANGE ZN	2
16	14760	ASM, MUFFLER W/ AIR INJ MOUNT-6150/7150	1
17	14433	BOLT, M8 X 1.25 X 15 FHCS ZN	3
18	14439	BOLT, M8 X 1.25 X 40 FHCS ZN	1
19	14239	BOLT, M8 X 1.25 X 20 FHCS ZN	3
20	14200	BRACKET, #1 AIR CLEANER MNT - 6150/7150	1
21	14445	BOLT, M10 X 1.25 X 10 FHCS ZN	1
22	14484	GUARD, CHAIN - 150CC	1
23	14426	BOLT, M6 X 1.00 X 14 FHCS ZN	2
24	14434	BOLT, M8 X 1.25 X 16 FHCS ZN	1
25	14497	WASHER, M8 X 27 X 2 FLAT ZN	1
26	14762	AIR INJECTION ASM, MUFFLER - 6150/7150	1

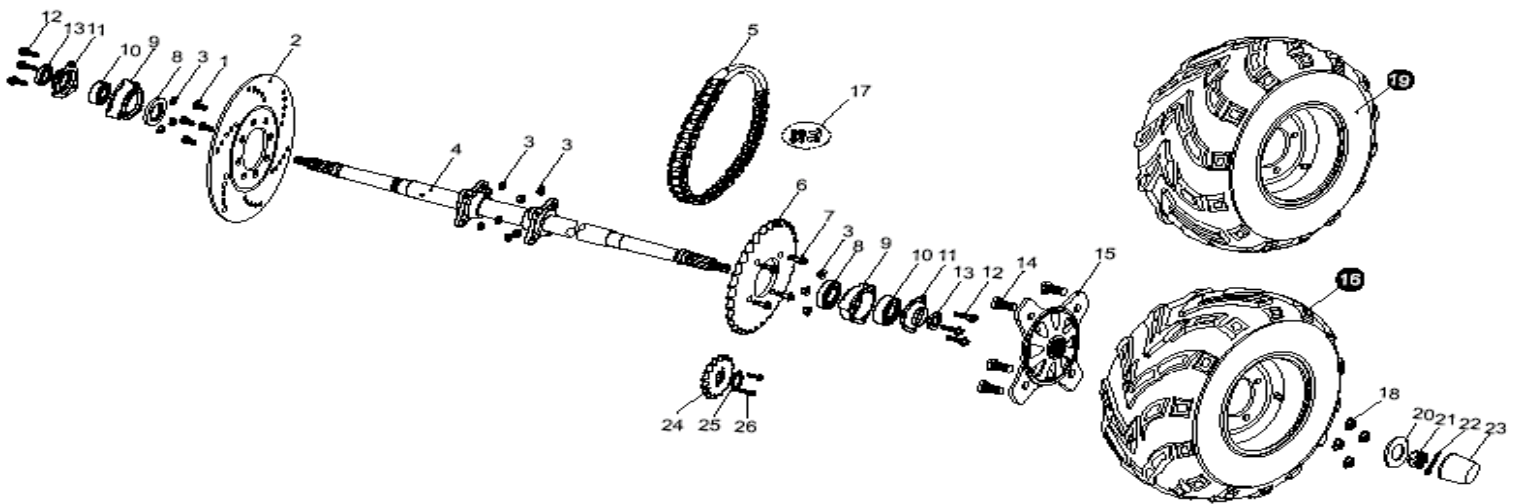

Ref#	Part#	Description	Qty
1	14435	BOLT, M8 X 1.25 X 22 FHCS ZN	4
2	14202	DISC, 8.75 REAR BRAKE - 6150/7150	1
3	14088	NUT, M8 X 1.25 LOCKING FLANGE ZN	16
4	14816	AXLE, TAPERED END - 200 SERIES	1
5	14204	CHAIN 50 X 52P INC ML	1
6	14205	SPROCKET, 50P 32T - 6150/7150	1
7	14436	BOLT, M8 X 1.25 X 25 FHCS ZN	4
8	14206	SEAL, M50 X 34 X 7 DUST	2
9	14207	HOUSING, AXLE BRG - 6150/7150	2
10	14208	BEARING - 6206	2
11	14209	FLANGE, BEARING - 6150/7150	2
12	14439	BOLT, M8 X 1.25 X 40 FHCS ZN	6
13	14210	SEAL, M42 X 30 X 7 DUST	2
14	14147	STUD, M10 X 1.25 X 31 WHEEL	8

Ref#	Part#	Description	Qty
15	15013	HUB, TAPERED 150CC - 4-165MM	2
16	14398	ASM, TIRE/WHL LR FAR EAST-6150	1
17	14215	MASTER LINK, 50	1
18	13979	NUT, M10 X 1.25 WF DAC	8
19	14399	ASM, TIRE/WHL RR FAR EAST-6150	1
20	14724	WASHER, 29.5 X 17MM X 3.0 ZN	2
21	14249	NUT, M16 X 2.00 CASTLE	2
22	14213	PIN, M4 X 30 COTTER	2
23	14151	CAP, HUB NOSE - BLACK RUBBER	2
24	14217	SPROCKET, 50P 16T - 6150/7150	1
25	14218	KEEPER, SPROCKET - 6150/7150	1
26	14296	BOLT, M6 X 1.00 X 12 FHCS ZN	2
27	14752	TIRE, 18 X 9.5-8 FAR EAST	1
28	14756	WHEEL, 8 X 4.75 4-165MM, SILVER	2

NOTE: parts denoted as left or right hand are from driver's point of view.

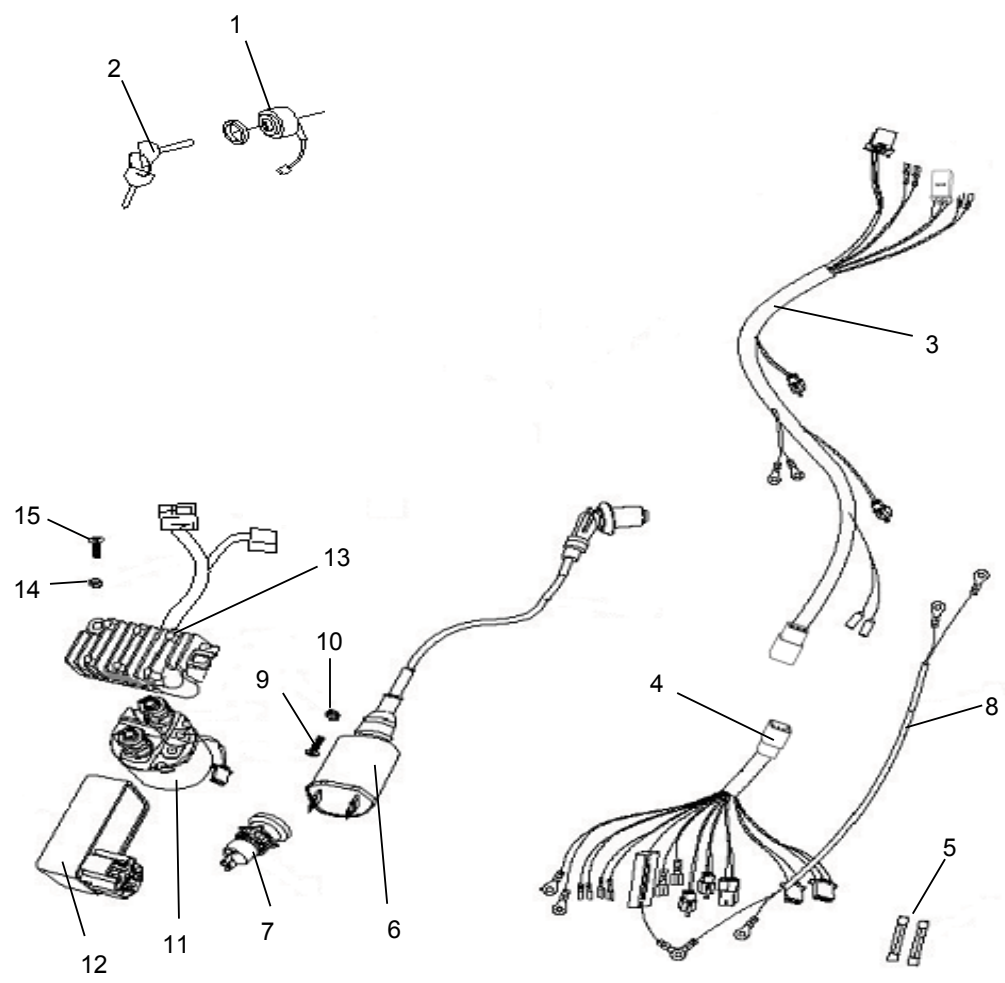

Ref#	Part#	Description	Qty
1	14222	SWITCH, KEYED IGNITION W/KEY - 6150/7150	1
2	14588	KEY SET - 6150/7150	1
3	15549	HARNESS, MAIN WIRING - See Specs	1
4	14743	HARNESS, SWINGARM WIRING - See Specs	1
5	14231	FUSE, 15AMP - WAYTEK 46115	2
6	14227	COIL, IGNITION W/CAP - 6150/7150	1
7	14221	SWITCH, ENGINE STOP - 6150/7150	2
8	14486	HARNESS, BATTERY - 150CC	1

Ref#	Part#	Description	Qty
9	14425	BOLT, M5 X .75 X 25 PHMS ZN	1
10	14491	NUT, M5 X .75 NYLOC ZN	1
11	14225	RELAY, STARTER - 6150/7150	1
12	14226	CDI - 6150/7150	1
	14572	CDI, 20MPH REV LIMITED-150CC	1
	14818	REGULATOR, VOLTAGE - 150CC	1
14	14428	SCREW, M6 X 1.00 X 20 PHMS ZN	2
15	14236	NUT, M6 X 1.00 NYLOC FLANGE ZN	7

NOTE: parts denoted as left or right hand are from driver's point of view.



ORDERING PARTS

FAST & EASY!

- 1) Seek Part(s) from your models illustrated diagram, cross over REF# to PART#
- 2) Type PART# into sites [Search Box] at GoKartsRus.com TIP! - RIGHT CLICK LINK, SELECT OPEN IN NEW TAB 
- 3) Add all needed parts to Shopping Cart | Complete "Checkout" | ✓ Done!

LOWEST PRICES!

If a part does not come up in a Site Search, please [Contact Us](#) (include part# in email)