

7150 Illustrated Parts Manual

14568R6

ORDERING PARTS

- 1) Seek Part(s) from your models illustrated diagram, cross over REF# to PART#
- 2) Type PART# into sites [Search Box] at GoKartsRus.com TIP! - RIGHT CLICK LINK, SELECT OPEN IN NEW TAB 
- 3) Add all needed parts to Shopping Cart | Complete "Checkout" | ✓ Done!

If a part does not come up in a Site Search, please [Contact Us](#) (include part# in email)

FAST & EASY!

LOWEST PRICES!

Section 1 - Cylinder Head Asm

Ref No	Part No	Description	QTY
1	14254	Head, Cylinder - 150cc	1
2	50304	Plug, Spark - NGK C7HSA	1
3	14255	Gasket, Cylinder Head - 150cc	1
4	14256	Gasket, Carb Insulator - 150cc	1
5	14257	Insulator, Carb - 150cc	1
6	14258	Manifold, Intake - 150cc	1
7	14259	Clamp, Carb Hose - 150cc	1
8	14260	Gasket, Valve Cover - 150cc	1
9	14261	O-Ring, M27x2 Rubber	1
10	14262	Tube, Breather - 150cc	1
11	14263	Stud, M6 x 1.00 x 18	2
12	14264	Stud, M6 x 1.00 x 50	2
13	50003	Bolt, M6 x 1.00 x 25 FHCS	4
14	50024	Nut, M6 x 1.00 Hex Flange	2
15	14265	Cover, Valve - 150cc	1
16	14266	Pin, M10 x 16 Dowel	2
17	50087	Bolt, M6 x 1.00 x 100 FHCS	2
18	14267	Valve, Intake - 150cc	1
19	14268	Seal, Valve Stem - 150cc	2
20	14269	Seat, Valve Spring Outer - 150cc	2
21	14270	Spring, Outer and Inner Valve - 150cc	2
22	14271	Retainer, Valve Spring - 150cc	2
23	14272	Keeper, Valve Spring - 150cc	4
24	14273	Valve, Exhaust - 150cc	1

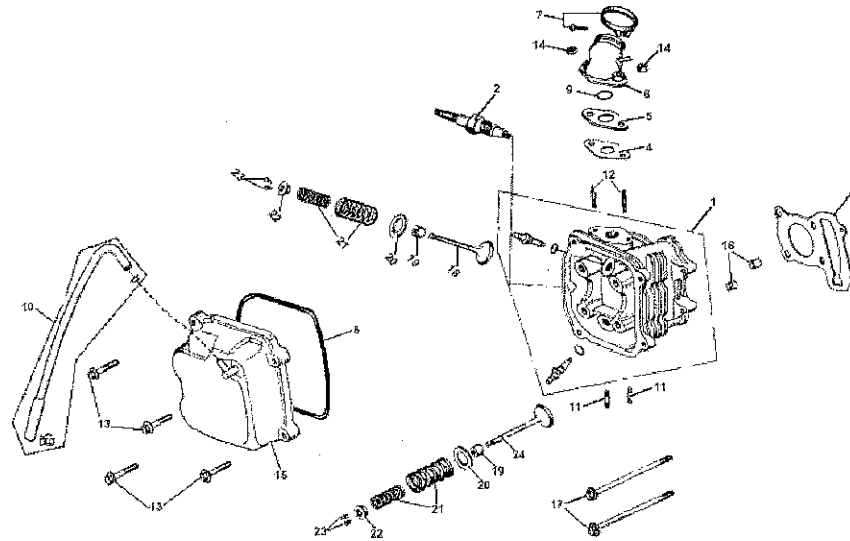

Section 2 - Cylinder

Ref No	Part No	Description	QTY
1	14317	Head, Cylinder - 150cc	1
2	14582	Gasket, Cyl Head Lower - 150cc	1
3	50032	Bolt, M6 x 1.00 x 22 FHCS	2
4	14266	Pin, M10 x 16 Dowel	2
5	14276	Tensioner, Cam Chain - 150cc	1
6	14275	Gasket, Cam Chain Tensioner - 150cc	1
7	14274	Asm, Cam Chain Tensioner - 150cc	1

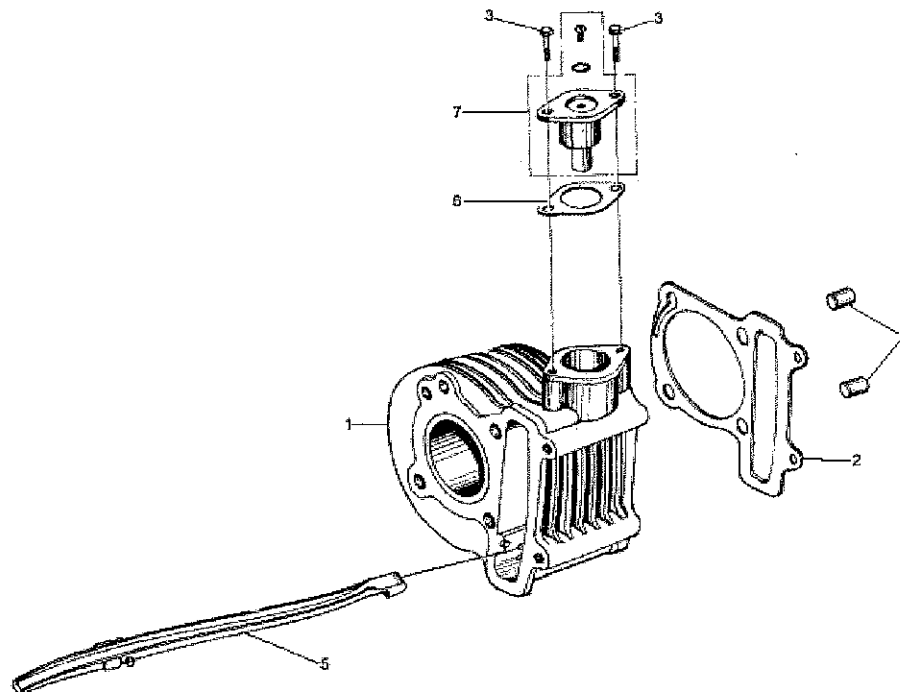

Section 3 - Engine Crankcase

Ref No	Part No	Description	QTY
1	14277	Housing, Crankcase RH - 150cc	1
2	14278	Bushing, Engine Hanger - 150cc	2
3	14279	Gasket, Crankcase - 150cc	1
4	14280	Housing, Crankcase LH - 150cc	1
5	14558	Grommet	1
6	14281	Bolt, M10 x 1.25 x 15 FHCS	1
7	14282	Washer, M10.2 x 18 x 1.3 Flat	1
8	14283	Cover, Small Left	1
9	14284	O-Ring, M108 x 2	1
10	14559	Pin	1
11	14285	O-Ring, M6 x 1.8	2
12	50104	Seal, M19.8 x 30 x 5	1
13	14286	Bolt, M6 x 1.00 x 18 FHCS	4
14	14287	Pin, M10 x 14 Dowel	2
15	14288	Bolt, M12 x 1.5 Special	1
16	14289	Washer, M12 Flat	2
17	14290	Seal, M20 x 32 x 6	2
18	14883	Tensioner, Cam Chain - 150cc	1
19	50016	Pin, M8 x 14 Dowel	2
20	14291	Stud, M8 x 1.25 x 195.5	2
21	14292	Stud, M8 x 1.25 x 187.5	2
22	14293	Washer, M8 Flat	4
23	14294	Nut, M8 x 1.25 Flange Head	4
24	14295	Bolt, M6 x 1.00 x 50 FHCS	2
25	14501	Spacer, Oil - 150cc	1
26	14296	Bolt, M6 x 1.00 x 12 FHCS	2

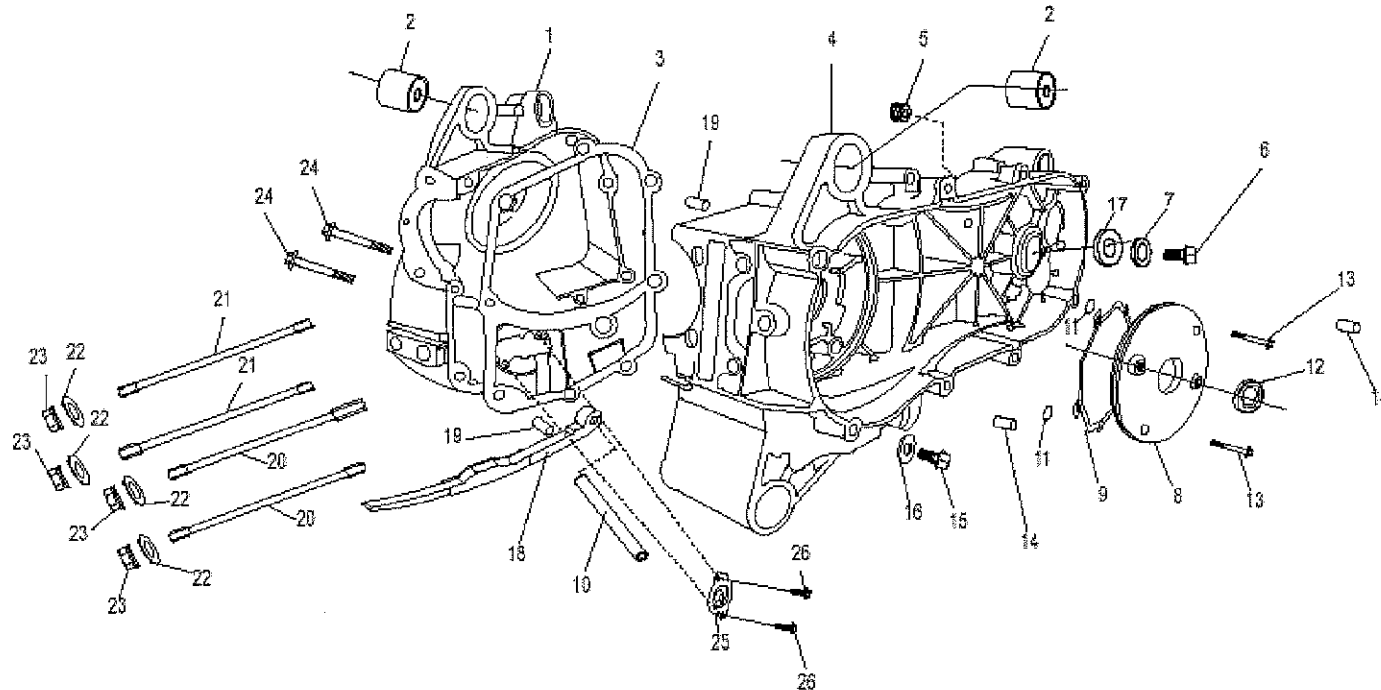

Section 4 - Transmission

Ref No	Part No	Description	QTY	Ref No	Part No	Description	QTY
1	14297	Housing, Outer Transmission - 150cc	1	20	14296	Bolt, M6 x 1.00 x 12 FHCS	2
2	14298	Gear, Pri Drive - 150cc	1	21	14315	Washer, M6 Flat	2
3	14299	Gear, Sec Drive - 150cc	1	22	14287	Pin, M10 x 14 Dowel	2
4	14300	Asm, Shift Gear Cluster F/N/R - 150cc	1	23	14316	Spacer, M15 Inner Gear	1
5	14301	Gear, Final Drive Shaft	1	24	Y00055	Bearing, 6202 15 x 35 x 11	1
6	14302	Asm, Shift Selector - 150cc	1	25	50102	Bearing, 6203 17 x 40 x 12	1
7	14303	Pawl, Shift Selector - 150cc	1	26	82407	Bearing, 6204 20 x 47 x 14	1
8	14304	Rod, Shift Pawl - 150cc	1	27	14106	Circlip, M20	1
9	14305	Shaft, Shifter Cam - 150cc	1	28	14503	Bearing, 6302 15 x 42 x 13	1
10	14306	Gasket, Transmission Case - 150cc	1	29	14504	Bearing, RNA4905 30 x 42 x 17	1
11	14307	Tube, Transmission Vent	1	30	14505	Bushing, Shock Absorbing - 150CC	2
12	14308	Nipple, Vent Tube - 150cc Large	1	31	14318	Seal, M30 x 40 x 6	1
13	14309	Ball, Shift Indent - 150cc	1	32	14598	Bearing, Sealed 6205 - 150CC	1
14	14310	Spring, Shift Indent - 150cc	1	33	14511	Washer, M22 X 31 X 2.5 Flat	1
15	14311	Gasket, Shift Indent - 150cc	1	34	14319	Circlip, M25	1
16	14312	Bolt, Shift Indent - 150cc	1	35	14320	Circlip, M52	1
17	14502	Nipple, Vent Tube - 150cc Small	1	36	14321	Clamp, Wire	1
18	14313	Bolt, Drain/Fill Plug - 150cc	2	37	14235	Bolt, M6 x 1.00 x 40 FHCS	10
19	14314	Gasket, Trans Drain Plug - 150cc	2	38	14597	Oil Seal, Shifter Cam - 150CC	1

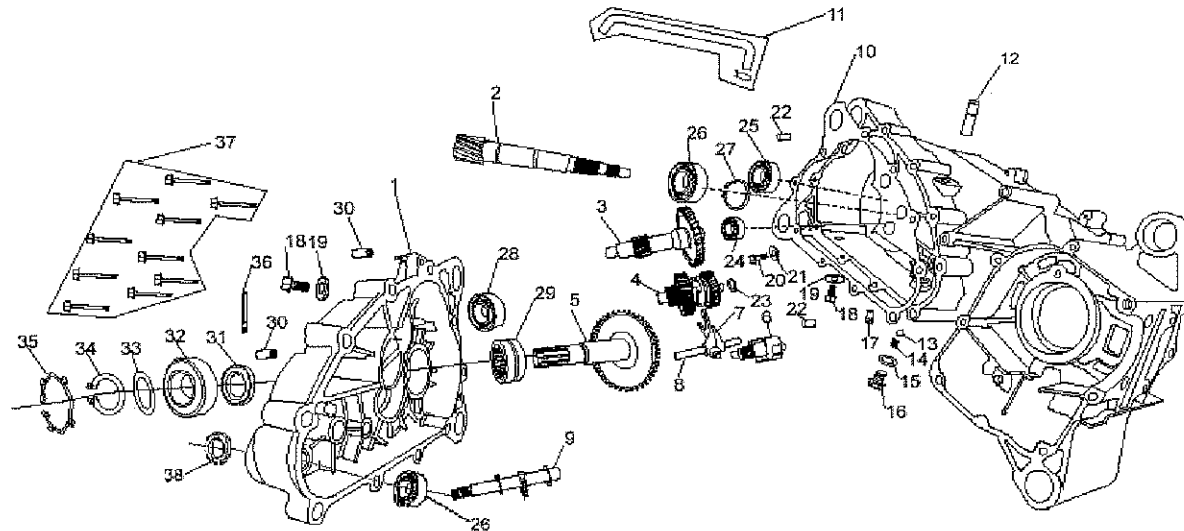

Section 5 - CVT Cover

Ref No	Part No	Description	QTY
1	14323	Cover, CVT - 150cc	1
2	14507	Bracket, Exhaust - 150cc	1
3	14324	Nut, M12 x 1.25 Locking Flange	1
4	14508	Bearing, 6200 10 x 30 x 9	2
5	14325	Gasket, CVT Cover - 150cc	1
6	14235	Bolt, M6 x 1.00 x 40 FHCS	8
7	14322	Snorkel, CVT - 150cc	1
8	14322	Snorkel, CVT - 150cc	1
9	14509	Clamp, Snorkel - 150cc	2

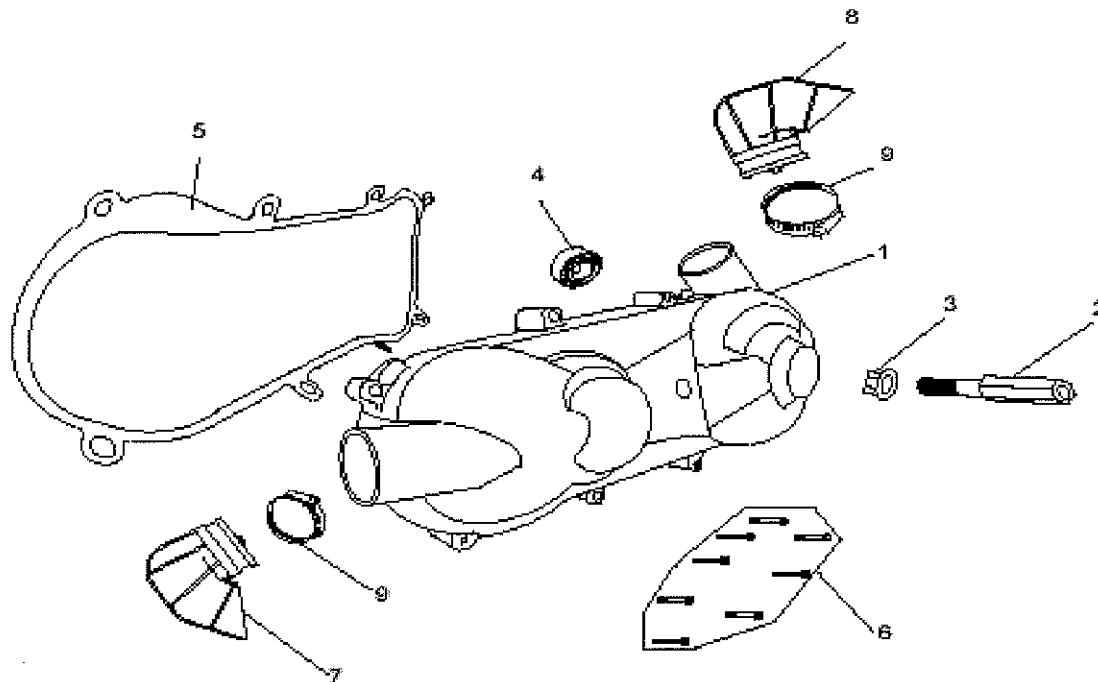

Section 6 - Outer Crankcase Asm

Ref No	Part No	Description	QTY
1	14326	Cover, Outer Crankcase RH - 150cc	1
2	14327	Gasket, Outer Crankcase - 150cc	1
3	14328	Cap, Oil Drain - 150cc	1
4	14329	Screen, Oil Filter - 150cc	1
5	14330	Spring, Oil Filter Screen - 150cc	1
6	14331	Dipstick, Oil Fill - 150cc	1
7	14332	Clamp, AC Generator - 150cc	1
8	14333	Seal, M19.8 x 30 x 5 Oil	1
9	14334	O-Ring, M30.8 x 3	1
10	14335	O-Ring, M18 x 3	1
11	50016	Pin, M8 x 14 Dowel	2
12	14336	Bolt, M6 x 1.00 x 28 FHCS	1
13	14337	Bolt, M6 x 1.00 x 95 FHCS	4
14	14338	Bolt, M6 x 1.00 x 100 FHCS	1
15	14339	Bolt, M6 x 1.00 x 110 FHCS	2
16	14340	Bolt, M6 x 1.00 x 35 FHCS	1
17	14341	Bolt, M6 x 1.00 x 20 FHCS	2
18	14296	Bolt, M6 x 1.00 x 12 FHCS ZN	2

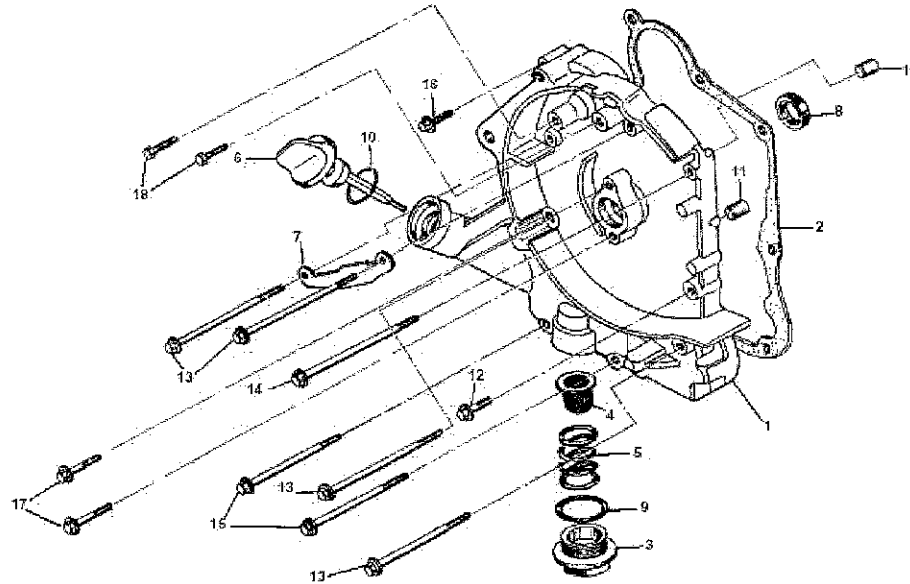

Section 7 - Piston, Crank and Connecting Rod

Ref No	Part No	Description	QTY
1	14342	Asm, Crank - Con Rod - 150cc	1
2	14324	Nut, M12 x 1.25 Hex Flange	1
3	14510	Nut, M22 x 1.00 Spanning - 150CC	1
4	14511	Washer, M22 x 31 x 2.5 Flat	1
5	14344	Gear, Kick Drive	1
6	14289	Washer, M12 Flat	1
7	14324	Nut, M12 x 1.25 Hex Flange	1
8	14512	Key, Woodruff M4 x 14	1
9	14345	Clip, Piston Retaining - 150cc	2
10	14346	Pin, Piston Wrist - 150cc	1
11	14347	Piston - 150cc	1
12	14348	Kit, Piston Ring - 150cc	1

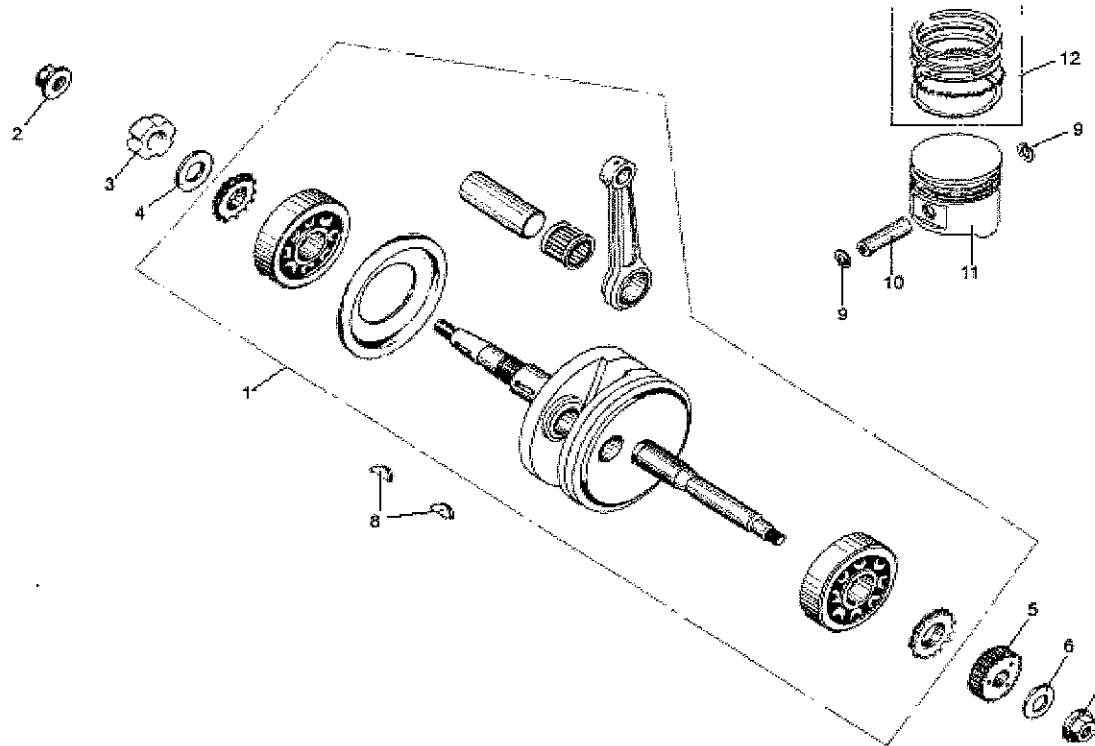

Section 8 - Camshaft Asm

Ref No	Part No	Description	QTY
1	14513	Nut, M5 x 0.5 Hex	2
2	14349	Screw, Tappet Adjustment - 150cc	2
3	14350	Arm, Valve Rocker - 150cc	2
4	14351	Shaft, Exhaust Rocker Arm - 150cc	1
5	14352	Chain, Camshaft - 150cc	1
6	14353	Camshaft - 150cc	1
7	14354	Shaft, Intake Rocker Arm - 150cc	1
8	14355	Plate, Stop - 150cc	1
9	14266	Pin, M10 x 16 Dowel	2
10	14356	Cap, Camshaft Brg - 150cc	1

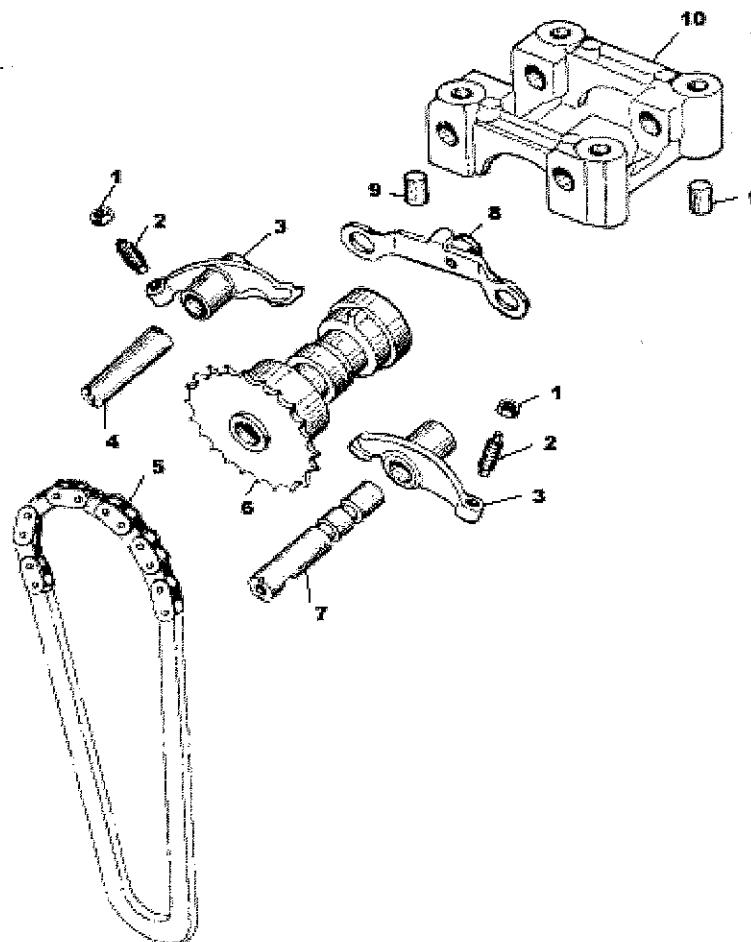

Section 9 - Oil Pump Asm

Ref No	Part No	Description	QTY
1	14357	Chain, Oil Pump - 150cc	1
2	14358	Nut, M6 x 1.00 Hex Flange	1
3	14359	Sprocket, Oil Pump - 150cc	1
4	14360	Bolt, M6 x 1.00 x 30 FHCS	2
5	14361	Asm, Oil Pump - 150cc	1

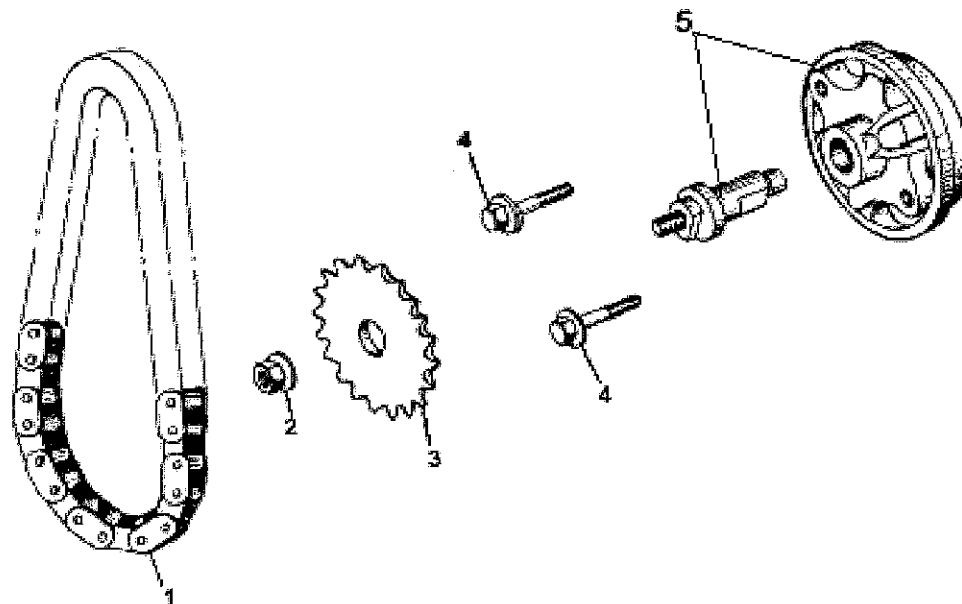

Section 10 - Driven Pulley and Clutch

Ref No	Part No	Description	QTY
1	14362	Asm, Outer Clutch - 150cc	1
2	14363	Belt, CVT - 150cc	1
3	14364	Asm, Driven Pulley - 150cc	1

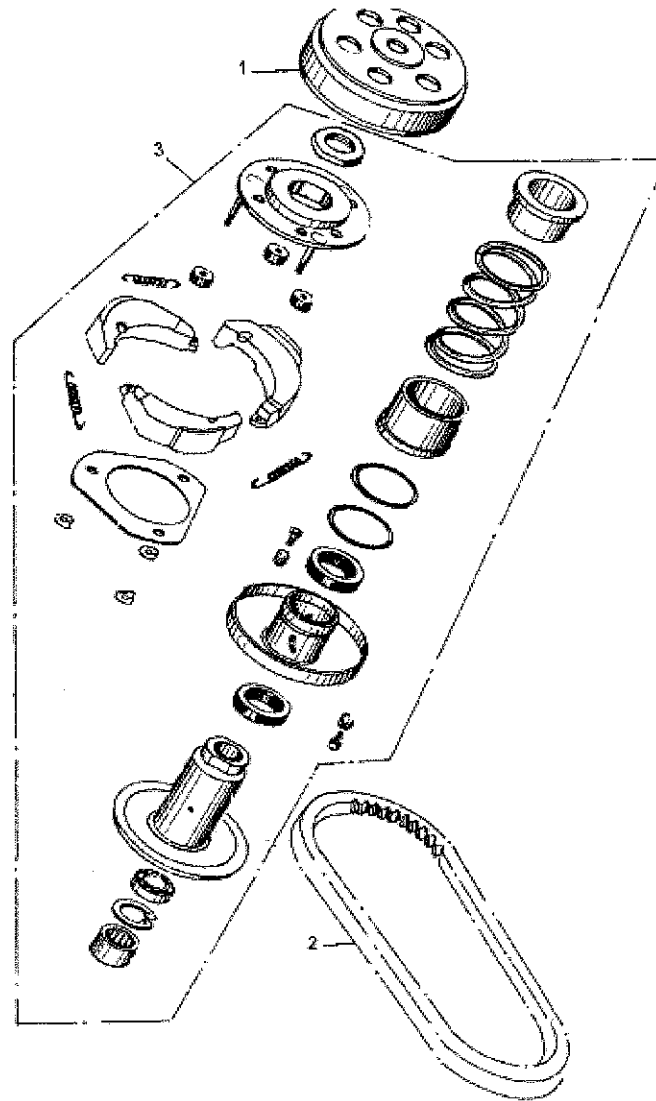

Section 11 - Engine Electrical

Ref No	Part No	Description	QTY
1	14365	Magneto - 150cc	1
2	14366	Flywheel - 150cc	1
3	14367	Fan, Cooling - 150cc	1
4	14368	Bolt, M6 x 1.00 x 15 FHCS	4

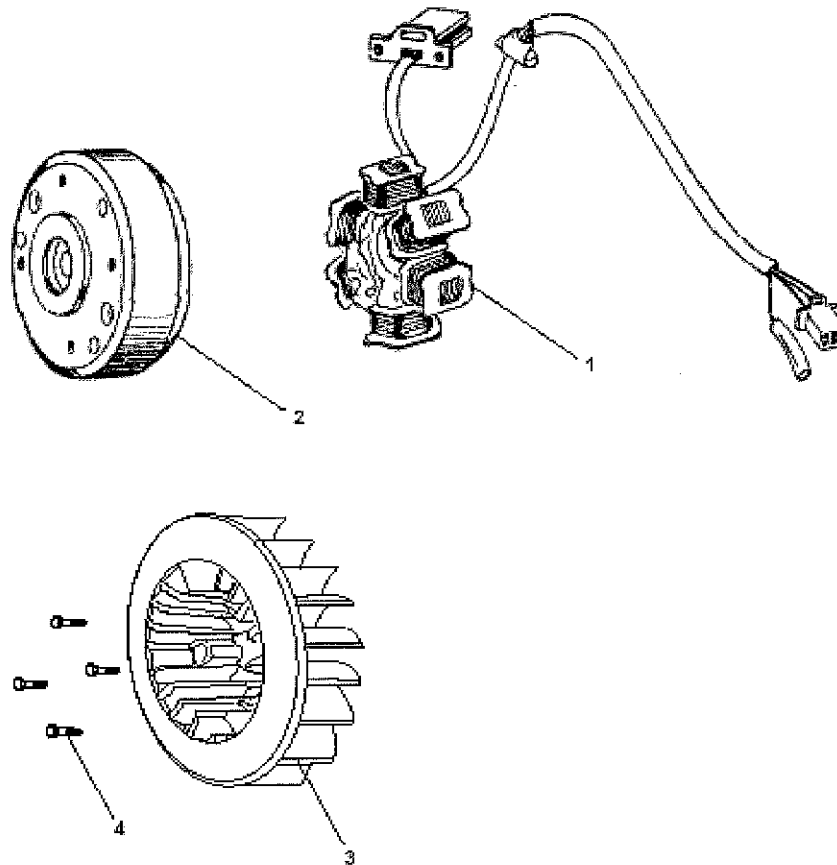

Section 12 - Electric Start

Ref No	Part No	Description	QTY
1	14369	Asm, Starter Clutch - 150cc	1
2	14370	Shaft, Starter Red - 150cc	1
3	14371	Gear, Starter Red - 150cc	1
4	14372	Bolt, M6 x 1.00 x 16 FHCS	2
5	14373	Asm, Starter Motor - 150cc	1

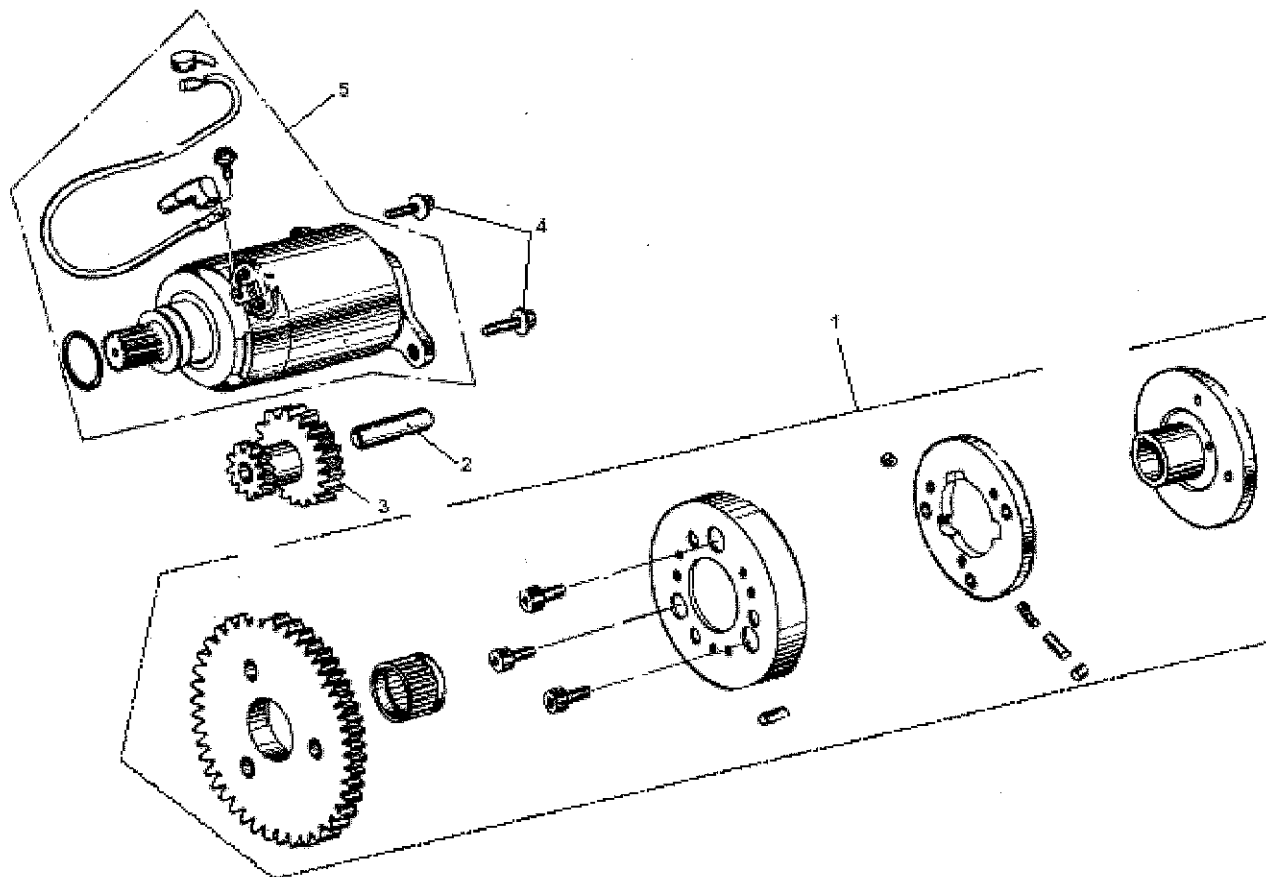

Section 13 - Driver Pulley

Ref No	Part No	Description	QTY
1	14374	Asm, Driver Pulley - 150cc	1
2	14375	Weights, Driver Pulley - 150cc	6

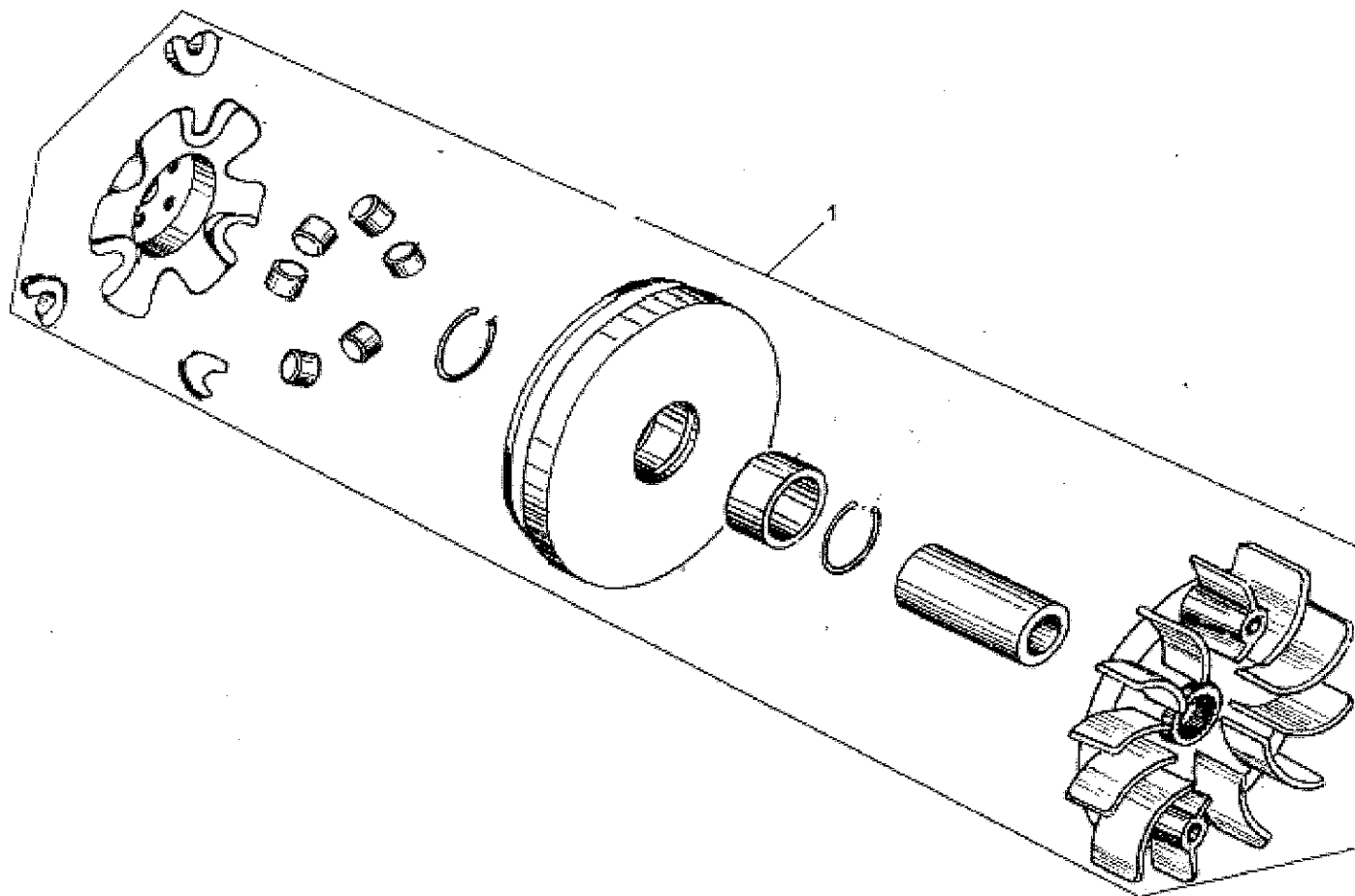

Section 14 - Oil Cooler (7150 Model Only)

Ref No	Part No	Description	QTY
1	14376	Manifold, Oil Cooler-150cc, W/ Filter (For units with placement just behind seat)	1
1a	14376A	Manifold, Oil Cooler-150cc, W/out Filter (For units with placement down near axle)	1
2	14514	Filter, Oil - 150cc (Seal included)	1
3	14537	Bolt, M12 X 28 Brake Banjo	4
4	14538	Washer, Oil Line	8
5	14515	Hose, Oil Cooling - 150cc (Shorter - 400MM) (#1 / #1a)	1 / 2
7	14599	Hose, Oil Cooling - 150cc (Longer - 540MM, for units with placement just behind seat)	1
8	14747	Bolt, M8 X 1.25 X 75 (For mounting behind seat)	2
8a	14086	Bolt, M8 X 1.25 X 55 FHCS ZN (For mounting near axle)	2
9	14088	Nut, M8 X 1.25 Locking Flange ZN	2
10	14748	Washer, M8 Split Lock (Only needed for mounting behind seat)	2
11	14293	Washer, M8 Flat ZN (Only needed for mounting behind seat)	2

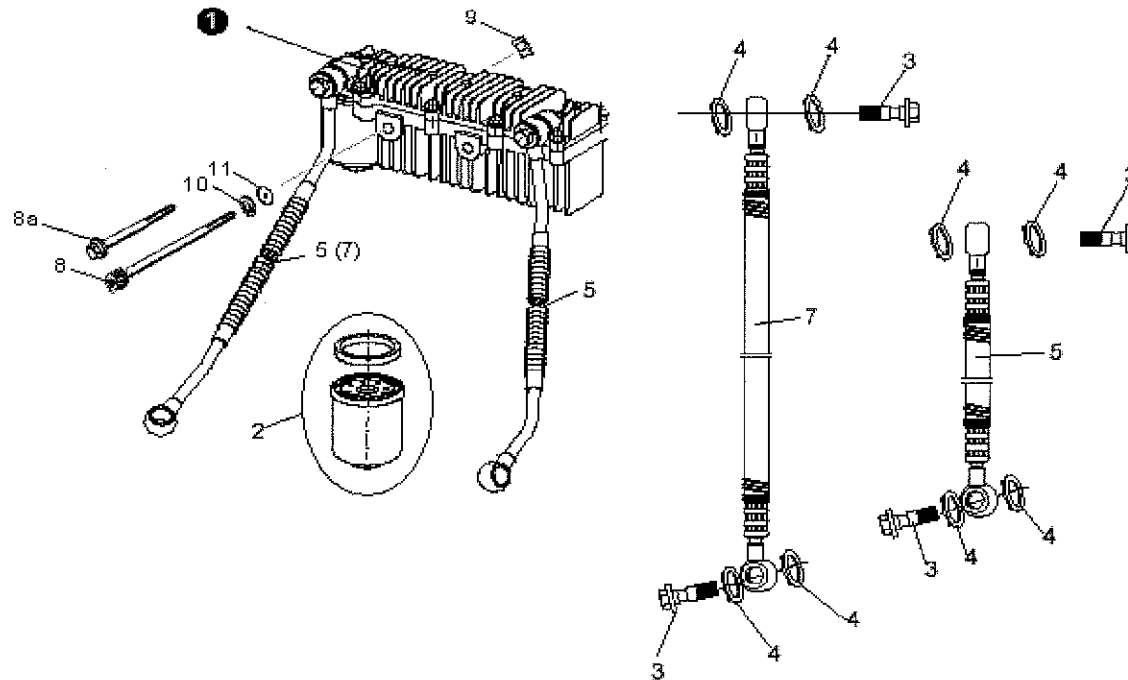

Section 15 - Fan Cover and Shroud Asm

Ref No	Part No	Description	QTY
1	14540	Cover, Fan Comp - 150cc	1
2	14541	Cover, Dust - 150cc	1
3	14542	Duct, Carburetor Cooling - 150cc	1
4	14543	Shroud, Lower - 150cc	1
5	14544	Seal, Lower Shroud - 150cc	1
6	14545	Shroud, Upper - 150cc	1
7	14546	Clip, Cord - 150cc	1
8	14547	Seal, Upper Shroud - 150cc	1
9	50065	Screw,	6
10	50069	Bolt, M6 x 25 FHCS	3
11	14539	Screw, 3.5 x 13 STFH	3

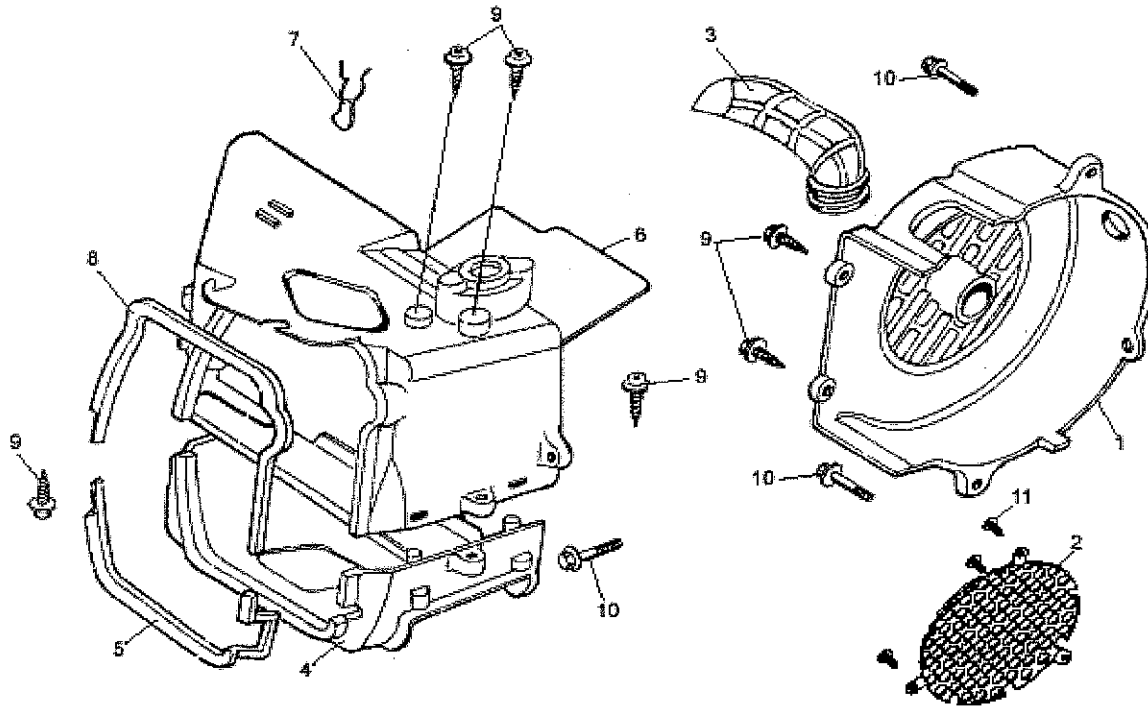

Section 16 - Carburetor

Ref No	Part No	Description	QTY
1	14561	KIT, CARB GASKET - 150CC	1
2	14562	KIT, CARB VACUUM - 150CC	1
3	14563	KIT, CARB CHOKE - 150CC	1
4	14564	KIT, CARB REBUILD - 150CC	1
5	14764	SCREW, M5 X 0.80 X 10 PH W/ SPLIT LOCK	3
6	14566	SCREW, M4 X 14 PH	2
7	14567	SCREW, M4 X 10 PH	2

Ref No	Part No	Description	QTY
1	14910	KIT, GASKET 150CC KEIHIN	1
2	14911	KIT, JET 150CC KEIHIN	1
3	14913	KIT, DIAPHRAM	1
4	14924	ASM, AUTOCHOKE	1
5	14925	ASM, CARBURETOR 150CC KEIHIN	1

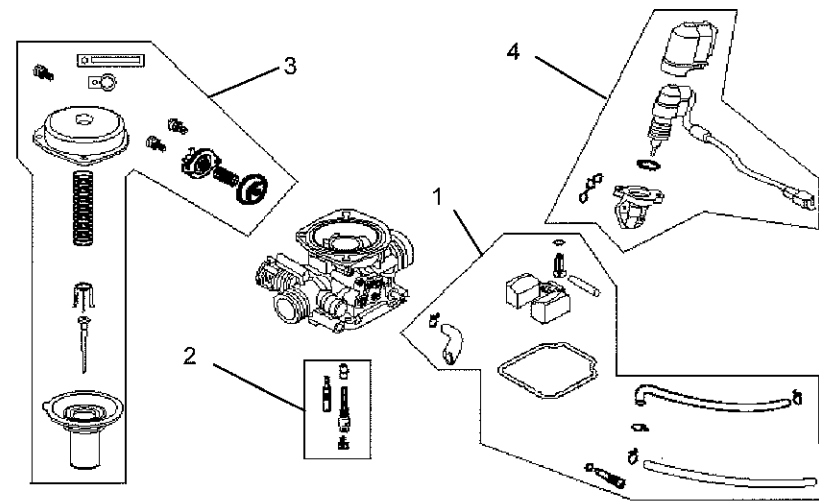
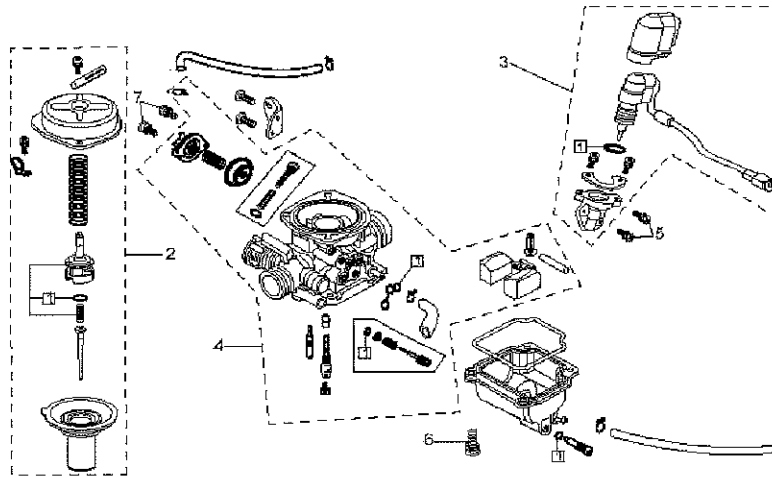

Keihin Carburetor

Section 17 - Frame Group

Ref No	Part No	Description	QTY
1	14080	BAR, REAR C PILLAR - 7150 - CHARCOAL	1
2	14081	WDMT, OH CROSS - 7150 - CHARCOAL	1
3	14082	BAR, OH FRONT - 7150 - CHARCOAL	2
4	14083	ENDCAP, BAR - 1.25 BLACK PLASTIC	4
5	14089	BAR, LH B PILLAR - 7150 - CHARCOAL	1
6	14085	BAR, RH B PILLAR - 7150 - CHARCOAL	1
7	14086	BOLT, M8 X 1.25 X 55 FHCS ZN	14
8	14087	WASHER, 8M CONCAVE CLAMP ZN	20
9	14491	NUT, M5 X .75 NYLOC ZN	4
10	14088	NUT, M8 X 1.25 LOCKING FLANGE ZN	6
11	13096	35WATT REPLACEMENT BULB	2
12	14090	ASM, REAR VIEW MIRROR - 7150	1
13	14494	WASHER, M5 SPLIT LOCK ZN	3
14	14098	WASHER, MIRROR MOUNT - 7150	1
15	14425	BOLT, M5 X .75 X 25 PHMS ZN	1
16	14093	ASM, FRONT BUMPER - 7150 - RED	1
17	14247	BOLT, M8 X 1.25 X 45 FHCS ZN	4
18	13831	ASM, LIGHT W/FLAT MOUNT TAB	2
19	14820	BOLT, M6 X 1.00 X 14 FHSS	4
20	14236	NUT, M6 X 1.00 NYLOC FLANGE ZN	6
21	13827	FENDER - FRONT 6150/7150	2
22	14235	BOLT, M6 X 1.00 X 40 FHCS ZN	2
23	14096	BRACKET, RH FRONT FENDER - BLK - 7150	1
24	14094	CABLE, THROTTLE - 6150/7150	1
25	14456	CABLE, D/N/R SHIFT - 150CC	2
26	14095	CABLE, PARK BRAKE - 7150	1
27	14097	BRACKET, LH FRONT FENDER - BLK - 7150	1
28	14092	PAD, RUBER FOOT - 7150	4
29	14084	ENDCAP, BAR - 1.00 BLACK PLASTIC	4
30	14091	PAD, FOAM B PILLAR W/WRAP - 7150	2
31	14099	HOOD, STEEL 7150 - RED	1
32	14820	BOLT, M6 X 1.00 X 14 FHSS	4
33	14235	BOLT, M6 X 1.00 X 40 FHCS ZN	2
34	14236	NUT, M6 X 1.00 NYLOC FLANGE ZN	2
35	14457	SCOOP, AIR INTAKE - 7150	1
36	14424	BOLT, M5 X .75 X 20 FHCS ZN	2
37	14591-48	FRAME - 7150L-0, CHARCOAL	1
38	14453	BOLT, M5 X .75 X 15 PHMS ZN	2
39	14401	BRACKET, HEADLIGHT MOUNTING - 6150/7150	2

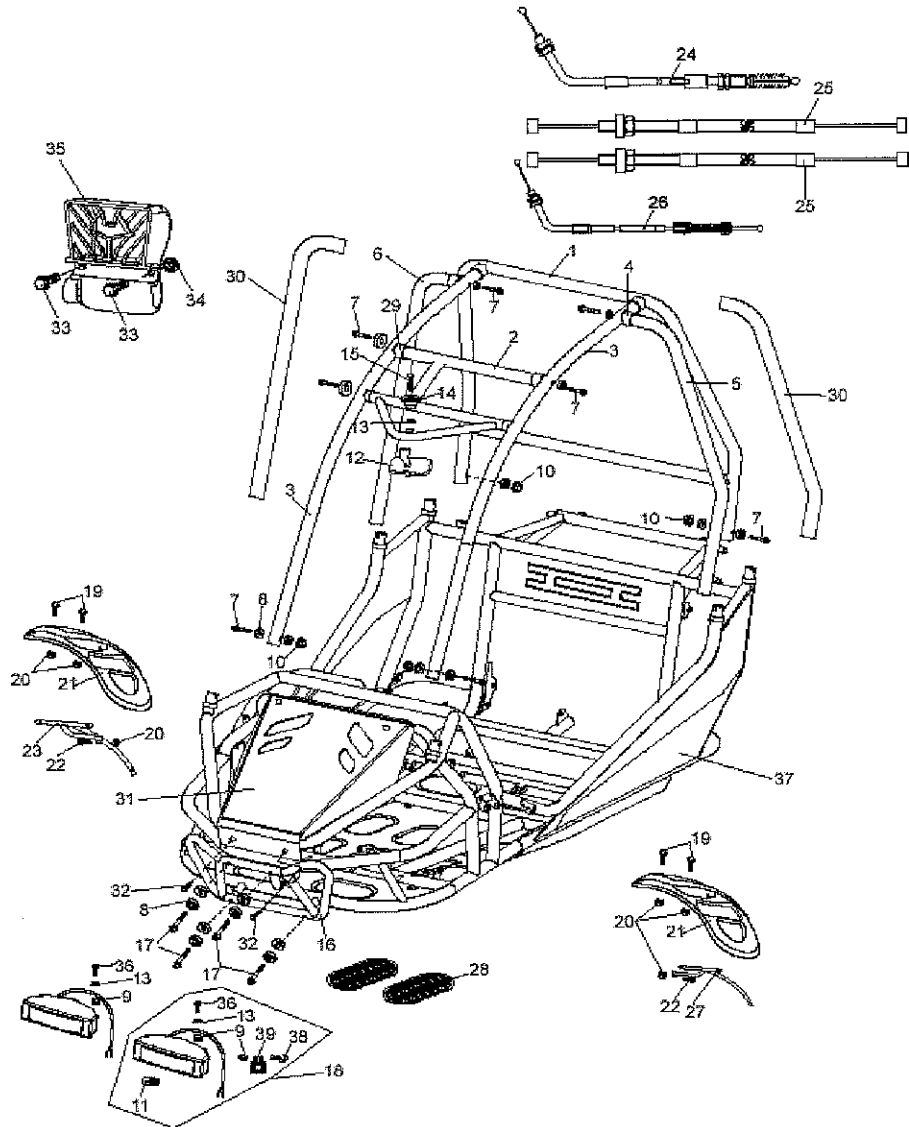

Section 18 - Steering and Brakes

Ref No	Part No	Description	QTY
1	14100	COVER, STEERING WHEEL - 6150/7150	1
2	14237	BOLT, M6 X 1.00 X 12 HHCS ZN	3
3	14238	WASHER, M6 SPLIT LOCK ZN	3
4	14102	STEERING WHEEL - 6150/7150	1
5	14103	SHAFT, STEERING - 7150	1
6	14104	BUSHING, FLANGED SLEEVE 20 X 28 X 24.1	2
9	14437	BOLT, M8 X 1.25 X 25 HHCS ZN	2
10	14495	WASHER, M8 SPLIT LOCK ZN	2
11	14107	SHAFT, STEERING U-JOINT - 7150	1
12	14108	ASM, RACK AND PINION - 7150	1
13	14436	BOLT, M8 X 1.25 X 25 FHCS ZN	4
14	14459	ASM, TIE ROD END - 7150	2
15	14123	PAD, BRAKE PEDAL - BLK - 7150	2
16	14131	CAP, BRAKE MASTER CYL - 7150	1
17	14125	KNOB, STEERING TILT - 7150	1
18	14126	BUSHING, FLANGED SLEEVE 12 X 16 X 12	2
19	14444	BOLT, M8 X 1.25 X 240 HHCS ZN	1
20	14240	WASHER, M10 FLAT ZN	2
21	14241	WASHER, M10 SPLIT LOCK ZN	2
22	14242	NUT, M10 X 1.25 CASTLE	2
23	14110	PIN, M2 X 15 COTTER	2
24	14111	BRACKET, TILT STEERING - CHARCOAL - 7150	1
25	14112	BRACKET, RACK AND PINION MNT	2
26	14088	NUT, M8 X 1.25 LOCKING FLANGE ZN	8
27	14442	BOLT, M8 X 1.25 X 145 HHCS ZN	1
28	14113	SPRING, THROTTLE PEDAL - 7150	1
29	14439	BOLT, M8 X 1.25 X 40 FHCS ZN	2
30	14610	NUT, M8 X 1.25 DAC	2
31	14114	PEDAL, THROTTLE - BLACK - 7150	1
32	14453	SCREW, M5 X .75 X 15 PHMS ZN	2
33	14494	WASHER, M5 SPLIT LOCK ZN	2
34	14491	NUT, M5 X .75 NYLOC ZN	2
35	14115	PEDAL, BRAKE - BLACK - 7150	1
36	14116	PIN, M6 X 24 BRAKE BLOCK - 6150/7150	1
37	14117	PUSHROD, BRAKE ADJUST - 7150	2
38	14489	PIN, M2 X 12 COTTER	1

Ref No	Part No	Description	QTY
39	14118	SWITCH, BRAKE LIGHT - 7150	1
40	14454	SCREW, M3 X .5 X 6 PHMS ZN	2
41	14119	BUSHING, SLEEVE 12 X 21 X 12	4
42	14120	SPRING, BRAKE PEDAL - 7150	1
43	14443	BOLT, M8 X 1.25 X 222 HHCS ZN	1
44	14121	ASM, MASTER CYLINDER - 7150	1
45	14438	BOLT, M8 X 1.25 X 35 HHCS ZN	2
46	14122	PAD, THROTTLE PEDAL - BLK - 7150	1
47	14460	BOLT, M10 X 24 BRAKE BANJO	3
48	14128	HOSE, HYD BRAKE - 34"	1
49	14129	HOSE, HYD BRAKE - 43"	1
50	14130	HOSE, HYD BRAKE - 75"	1
51	14101	T BLOCK, BRAKE - 7150	1
52	14109	BOOT, R&P BLACK RUBBER - 7150	2
53	14127	WASHER, BRASS BRAKE LINE	6
54	14412	BOOT, STEERING SHAFT BLACK RUBBER - 7150	2
55	14738	DUST SHEILD, R & P BLACK RUBBER - 7150	1

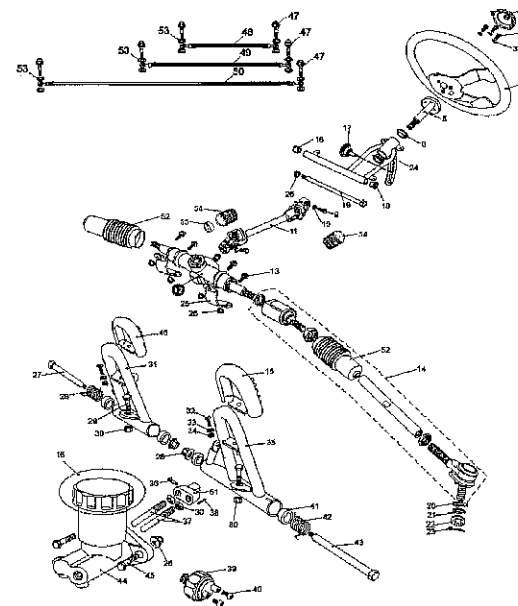

Section 19 - Front Suspension

Ref No	Part No	Description	QTY
1	14132	ASM, STRUT/SPINDLE RH-CHAR-7150	1
2	14133	BOLT, M8 X 1.25 X 105 FHCS ZN	2
3	14134	SPANNER, A ARM UPPER - 7150	2
4	14126	BUSHING, FLANGED SLEEVE 12 X 16 X 12	4
5	14136	A ARM, UPPER - RED W/ ZERK - 7150	2
6	14088	NUT, M8 X 1.25 LOCKING FLANGE ZN	2
7	14244	NUT, M12 X 1.25 CASTLE ZN	2
8	14137	SEAL, BALL JOINT - 6150/7150	4
9	14138	SPACER, BALL JOINT HEAD - 6150/7150	4
10	14139	ASM, STRUT/SPINDLE LH - CHAR - 7150	1
11	14455	BOLT, M8 X 1.25 X 14 SHCS PL	4
12	14140	SPANNER, A ARM LOWER - 7150	4
13	14237	BOLT, M6 X 1.00 X 12 HHCS ZN	12
14	14141	ASM, TIRE/WHL RF FAR EAST-7150	1
14a	14141A	ASM, TIRE/WHL RF SUN F-7150	1
15	14142	KIT, BRAKE PAD FRONT - 7150	2
16	14143	ASM, BRAKE CALIPER - LF - 7150	1
17	14144	DISC, FRONT BRAKE - 7150	2
18	14145	SEAL, M47 X 25 X 7 DUST	2
19	14146	BEARING, INNER - 6204-Z	2
20	14147	STUD, M10 X 1.25 X 31 WHEEL	8
21	14148	HUB, FRONT WHEEL - 6150/7150	2
22	14149	BEARING, OUTER - 6202-Z	2
23	14243	NUT, M10 X 1.25 LOCKING FLANGE ZN	8
24	14158	ASM, TIRE/WHL LF FAR EAST-7150	1
24a	14158A	ASM, TIRE/WHL LF SUN F-7150	1
25	14245	WASHER, M12 SPLIT LOCK ZN	2
26	14748	WASHER, M8 SPLIT LOCK	4
27	14490	PIN, M1.8 X 20 COTTER	4
28	14150	PIN, M2 X 20 COTTER	2
29	14151	CAP, HUB NOSE - BLACK RUBBER	2
30	14246	BOLT, M10 X 1.25 X 40 FHCS ZN	4
31	14152	ASM, BRAKE CALIPER - RF - 7150	1
32	14153	SHOCK, 325MM FRONT - CHR/M/YEL - 7150	2
33	14447	BOLT, M10 X 1.25 X 80 FHCS ZN	4
34	14154	CAP, DUST - LWR SUSP ARM - 7150	8
35	14155	BUSHING, FLANGED SLEEVE 15 X 21 X 18	8
36	14156	O-RING, M21.2 X 2.65	8
37	14157	A ARM, LOWER - RED W/ ZERK - 7150	2
38	14594	GREASE ZERK - 7150	6
39	14242	NUT, M10 X 1.25 CASTLE	2
40	14727	NUT, M14 X 1.25 CASTLE	2
41	14241	WASHER, M10 SPLIT LOCK ZN	2
42	14753	TIRE, 19 X 7-8 FAR EAST	2
43	14755	WHEEL, 8 X 5 4-110MM, SILVER	2

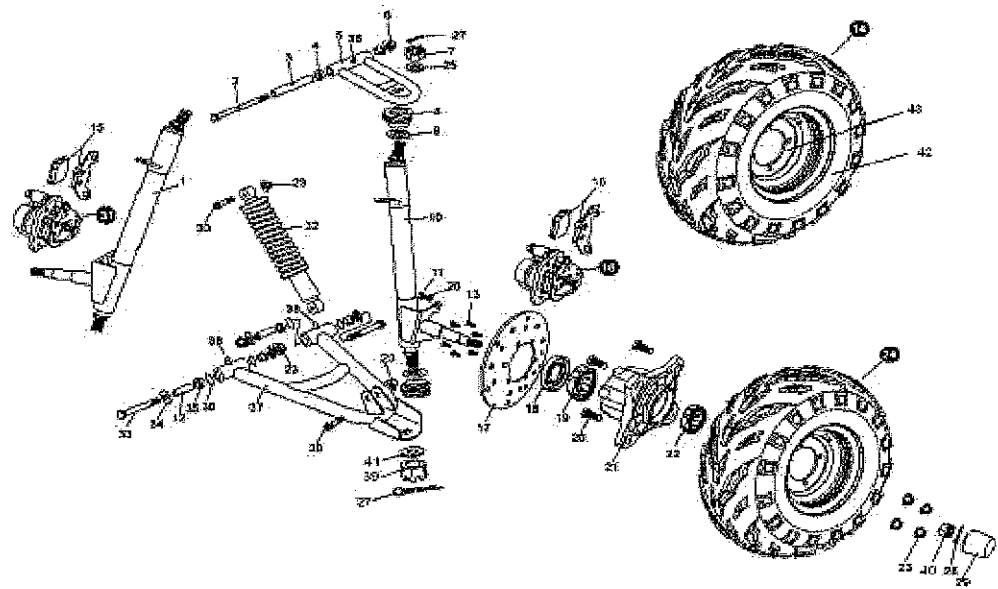

Section 20 - Rear Rack / Seat Details

Ref No	Part No	Description	QTY
1	14159	RACK, REAR CARGO - CHARCOAL - 7150	1
2	14083	ENDCAP, BAR - 1.25 BLACK PLASTIC	2
3	14160	ARM, RACK SPPT - CHARCOAL - 7150	2
4	14239	BOLT, M8 X 1.25 X 20 FHCS ZN	4
5	14088	NUT, M8 X 1.25 LOCKING FLANGE ZN	12
6	13871	CAP, FUEL - 6150/7150	1
7	14161	FUEL TANK - CHARCOAL - 6150/7150	1
8	14086	BOLT, M8 X 1.25 X 55 FHCS ZN	4
9	14162	SPACER, FUEL TANK - 150CC	4
10	14163	BUSHING, FUEL TANK MOUNT - 150CC	4
11	14293	WASHER, M8 FLAT ZN	4
12	14451	BOLT, M12 X 1.25 X 25 FHCS ZN	2
13	50210	AUTO COCK ASSEMBLY	1
14	14164	LINE, FUEL #1 - 6150/7150	1
15	14165	LINE, VACUUM #1 - 6150/7150	1
16	14166	LINE, FUEL #2 - 6150/7150	1
17	14167	FILTER, FUEL - 6150/7150	1
18	8778	HARNES LAP SHOULDER REST	2
19	14168	ASM, HEAD REST - BLK/RED - 7150	2
20	14169	SEAT, BUCKET - RH - BLK/RED - 7150	1
21	14170	SEAT, BUCKET - LH - BLK/RED - 7150	1
22	14324	NUT, M12 X 1.25 LOCKING FLANGE ZN	4
23	14289	WASHER, M12 FLAT ZN	4
24	14451	BOLT, M12 X 1.25 X 25 FHCS ZN	4
25	14171	SLIDE, SEAT (PR) - 6150/7150	1
26	14324	NUT, M12 X 1.25 LOCKING FLANGE ZN	2
27	14461	BULB, TAIL LIGHT - 12V 10/5W - 7150	1
28	14462	ASM, TAIL LIGHT W/BULB - 7150	1
29	14440	BOLT, M8 X 1.25 X 40 HHCS ZN	4
30	14463	CAP, M22 INTERNAL TUBE - BLK	2
31	14464	FLAG, SAFETY - SLI	1
32	14465	BOLT, M12 X 1.75 X 30 FLAG MOUNT	1
33	14466	NUT, 1.75 THREAD DECORATIVE PLSTC FLAG MNT	1
34	14595	NUT, M12 X 1.75 HEX ZN	1
35	80050	CLIP - 8 X 0.8	9
36	15256	CAP, SEAT BELT SHOULDER	2
37	14994	COVER, SEAT SLIDE HANDLE (BLK)	2

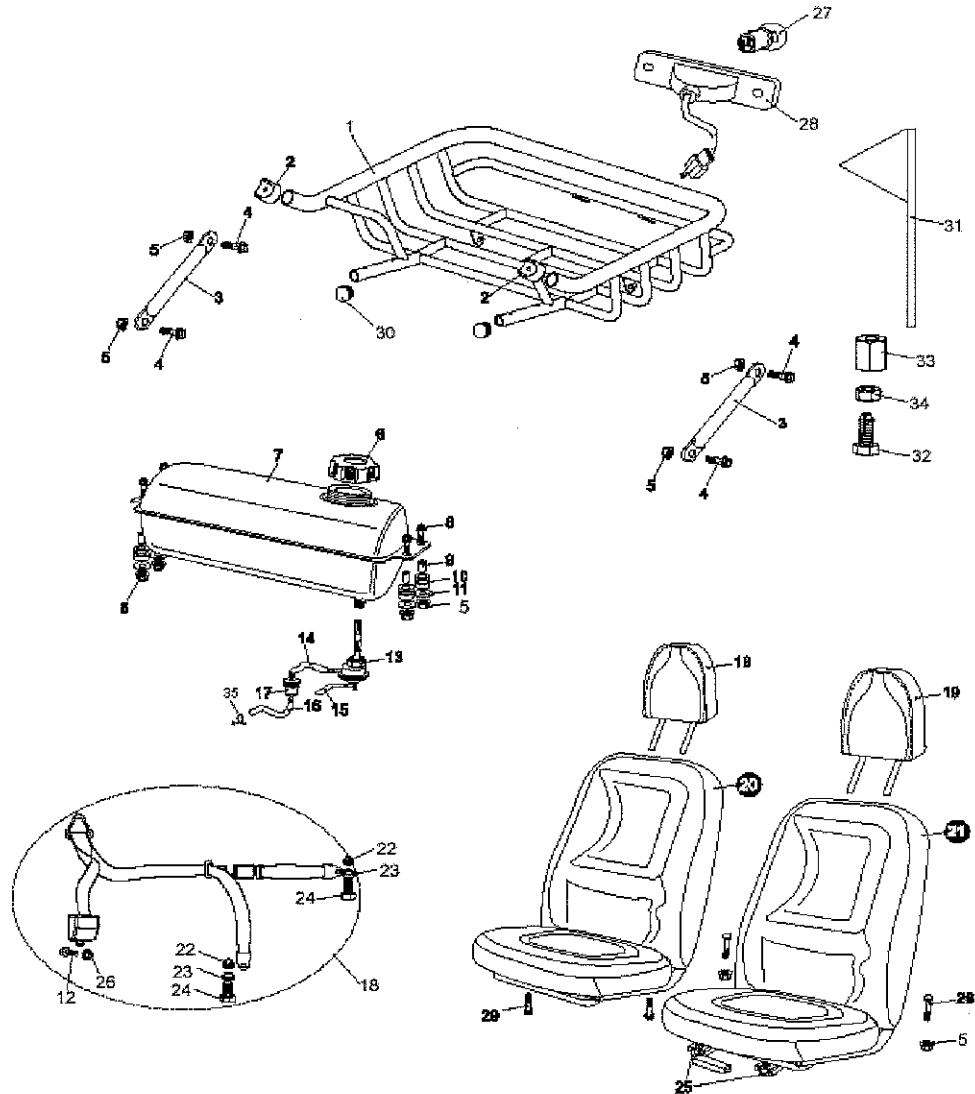

Section 21 - Rear Swingarm Asm (Upper)

Ref No	Part No	Description	QTY
1	14324	NUT, M12 X 1.25 LOCKING FLANGE ZN	3
2	14289	WASHER, M12 FLAT ZN	2
3	14467	BUSHING, ENGINE ADJ ISOLATOR - 150CC	1
4	14468	SPACER, ENGINE ADJ CUP - 150CC	1
5	14469	SPACER, ENGINE ADJ ALIGNMENT - 150CC	1
6	14479	DISC, SHIFT CONTROL - 150CC	1
7	14492	NUT, M12 X 1.25 HEX ZN	1
8	14470	LINK, CHAIN TENSIONING - 150CC	1
9	14243	NUT, M10 X 1.25 LOCKING FLANGE ZN	1
10	14446	BOLT, M10 X 1.25 X 45 FHCS ZN	1
11	14471	SPACER, ENGINE MOUNTING LINK - 150CC	1
12	14472	KNOB, PARK BRAKE SHIFT - BLK - 7150	1
13	14473	BRACKET, SHIFT CABLE - 150CC	1
14	14431	BOLT, M6 X 1.00 X 60 FHCS ZN	2
15	14172	COVER, ELECTRICAL - 6150/7150	1
16	14173	ASM, UPPER SWINGARM - CHARCOAL - 7150	1
17	14452	BOLT, M12 X 1.25 X 60 FHCS ZN	2
18	14420	SCREW, M4 X .75 X 31 PHMS ZN	1
19	14174	LINK, REAR SWINGARM - CHARCOAL - 7150	2
20	14175	BUSHING, FLANGED SLEEVE 15 X 21 X 10	8
21	14176	SPACER, SWINGARM LINK - 7150	4
22	14785	BOLT, M8 X 1.25 X 16 SHCS PL	4
23	14449	BOLT, M10 X 1.25 X 195 HHCS ZN	1
24	14177	SPANNER, ENGINE MOUNT - 6150/7150	1
25	14474	COVER, PARK BRAKE SHIFTER - 7150	1
26	14475	ASM, PARK BRAKE SHIFTER - 7150	1
27	14476	ADJUSTER, PARK BRAKE CABLE - 7150	1
28	14477	SPRING, PARK BRAKE SHIFT - 7150	1
29	14478	ASM, TRANS SHIFT LEVER - 150CC	1
30	14493	NUT, M4 X .75 HEX ZN	1
31	14594	GREASE ZERK - 7150	4
32	14748	WASHER, M8 SPLIT LOCK	4
33	14426	BOLT, M6 X 1.00 X 14 FHCS ZN	2

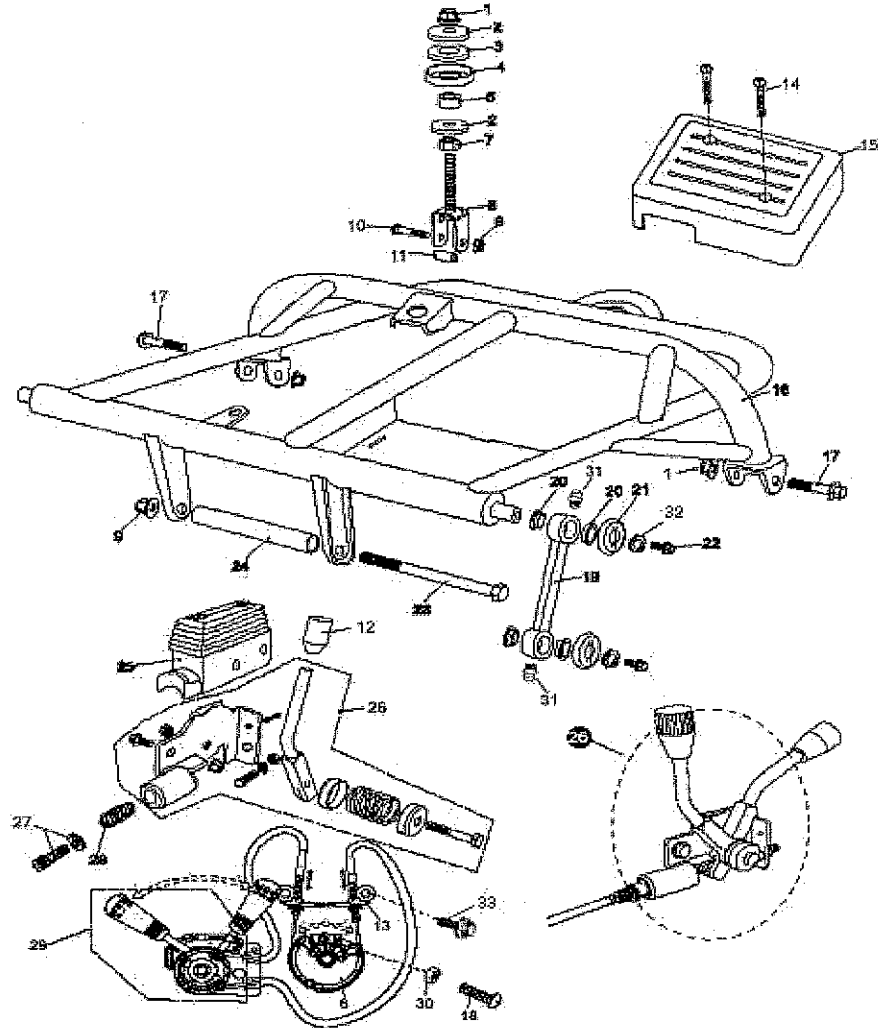

Section 22 - Engine/Muffler/Air Cleaner

Ref No	Part No	Description	QTY
1	14192	ASM, AIR CLEANER - 150CC	1
2	14423	SCREW, M5 X 16 PHSM ZN	9
3	14495	WASHER, M8 SPLIT LOCK ZN	1
4	14194	FILTER, AIR - 150CC	1
5	14201	BRACKET, #2 AIR CLEANER MNT - 6150/7150	1
6	14480	BRACKET, REAR ENG MOUNT - 150CC	1
7	14195	HOSE, AIR INTAKE - 150CC	1
8	14481	CLAMP, HOSE 45MM	3
9	14196	GASKET, EX PIPE - 150CC	1
10	14197	ASM, CARBURETOR - 6150/7150	1
11	15332	ASM, ENGINE - 150CC 615X/7150	1
12	14482	SPRING, EXHAUST PIPE - 150CC	2
13	50050	NUT (HEX) CAP M6	2
14	14236	NUT, M6 X 1.00 NYLOC FLANGE ZN	2
16	14199	ASM, MUFFLER W/SHIELD - 6150/7150	1
16a	14760	ASM, MUFFLER W/ AIR INJ MOUNT-6150/7150	1
17	14433	BOLT, M8 X 1.25 X 15 FHCS ZN	3
18	14439	BOLT, M8 X 1.25 X 40 FHCS ZN	1
19	14239	BOLT, M8 X 1.25 X 20 FHCS ZN	3
20	14200	BRACKET, #1 AIR CLEANER MNT - 6150/7150	1
21	14445	BOLT, M10 X 1.25 X 10 FHCS ZN	1
22	14484	GUARD, CHAIN - 150CC	1
23	14426	BOLT, M6 X 1.00 X 14 FHCS ZN	2
24	14434	BOLT, M8 X 1.25 X 16 FHCS ZN	1
25	14497	WASHER, M8 X 27 X 2 FLAT ZN	1
26	14762	AIR INJECTION ASM, MUFFLER - 6150/7150	1

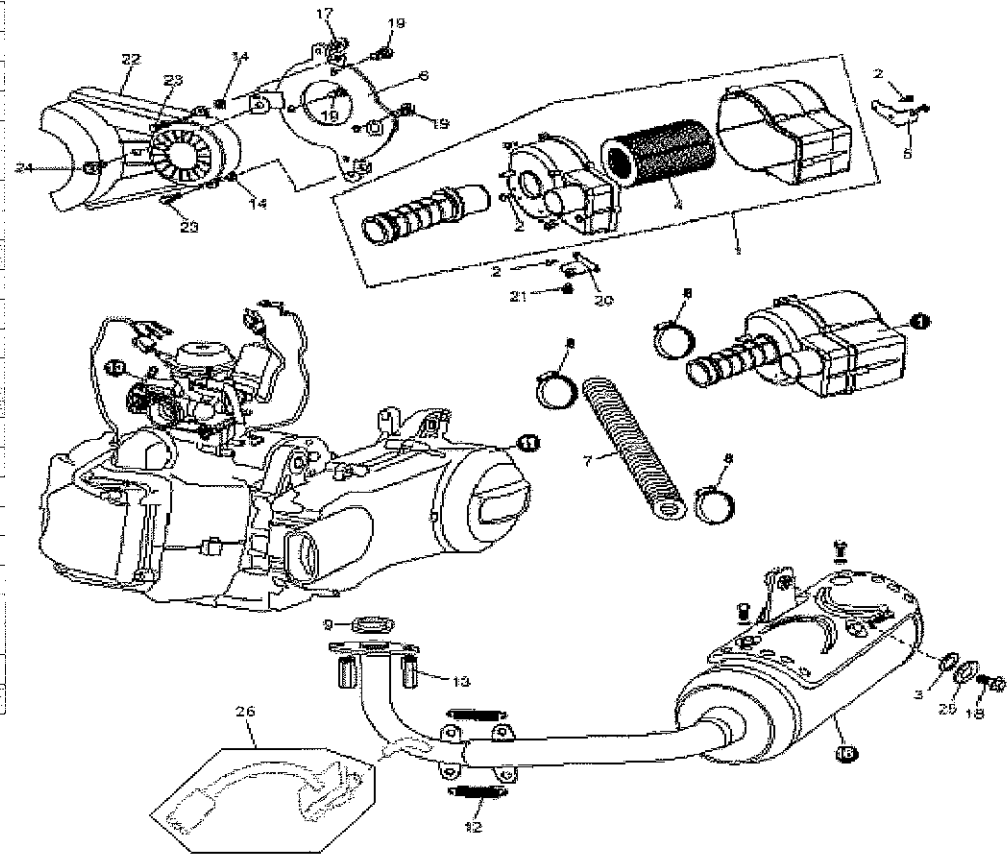

Section 23 - Rear Swingarm Asm (Lower)

Ref No	Part No	Description	QTY	Ref No	Part No	Description	QTY
1	14246	BOLT, M10 X 1.25 X 40 FHCS ZN	4	14	14183	KIT, REAR BRAKE PAD - 7150	1
2	14243	NUT, M10 X 1.25 LOCKING FLANGE ZN	4	15	14184	ASM, REAR CALIPER W/PARK - 7150	1
3	14535	SHOCK, REAR - CHR/YELLOW - 6150/7150	2	16	14185	GUARD, LOWER CHAIN - 6150/7150	1
4	14441	BOLT, M8 X 1.25 X 100 FHCS ZN	1	17	14186	COVER, BATTERY - 6150/7150	1
5	14179	BRACKET, LH REAR FENDER - BLK - 7150	1	18	14187	STRAP, BATTERY HOLD DOWN - 6150/7150	1
6	14236	NUT, M6 X 1.00 NYLOC FLANGE ZN	12	19	14188	GASKET, BATTERY CAP - 6150/7150	1
7	14247	BOLT, M8 X 1.25 X 45 FHCS ZN	2	20	14189	BATTERY - GTX9-BS	1
8	14372	BOLT, M6 X 1.00 X 16 FHCS ZN	6	21	14190	WDMT, LOWER SWINGARM - CHARCOAL - 7150	1
9	14180	FENDER, REAR - GBLACK - 6150/7150 9.5 IN	2	22	14324	NUT, M12 X 1.25 LOCKING FLANGE ZN	2
9a	14180A	FENDER, REAR-GBLACK - 6150/7150 10.5 IN	2	23	14191	BUSHING, SWINGARM ISOLATOR - 6150/7150	2
10	14432	BOLT, M8 X 1.25 X 12 HHCS ZN	1	24	14452	BOLT, M12 X 1.25 X 60 FHCS ZN	2
11	14181	BRACKET, RH REAR FENDER - BLACK - 7150	1	25	14500	WASHER, M8 STAR ZN	1
12	14182	BUSHING, REAR SWINGARM UPPER - 7150	4	26	14820	BOLT, M6 X 1.00 X 14 FHSS	6
13	14485	SPANNER, M18 X 37 - 150CC	2				

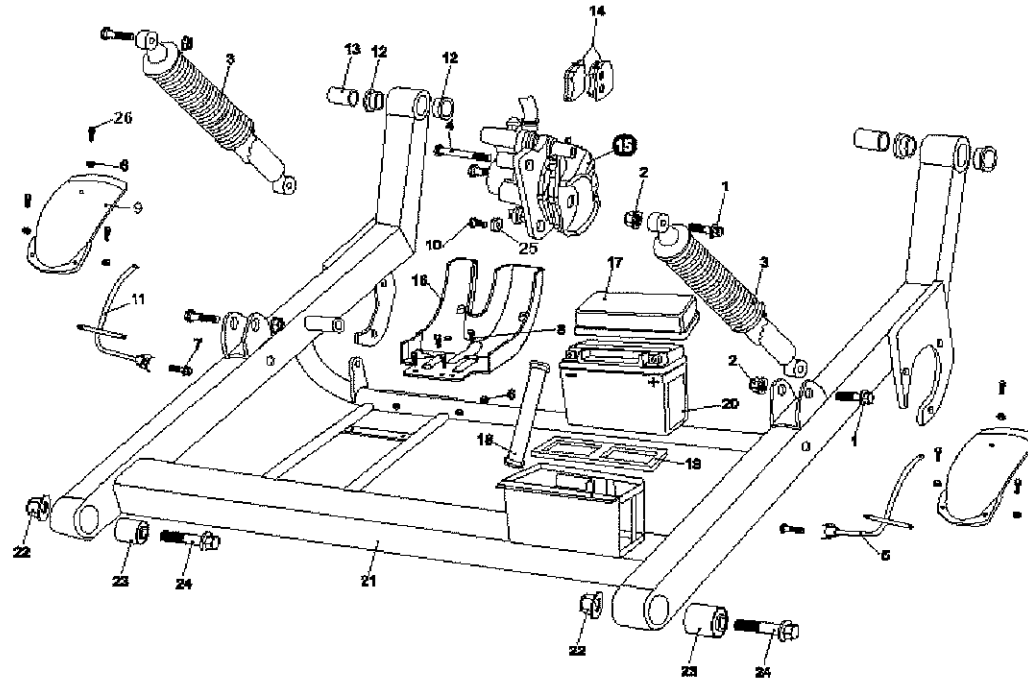

Section 24 - Rear Axle

Ref No	Part No	Description	QTY	Ref No	Part No	Description	QTY
1	14435	BOLT, M8 X 1.25 X 22 FHCS ZN	4	16	14212	ASM, TIRE/WHL RR FAR EAST-7150	1
2	14202	DISC, 8.75 REAR BRAKE - 6150/7150	1	16a	14212A	ASM, TIRE/WHL RR SUN F-7150	1
3	14088	NUT, M8 X 1.25 LOCKING FLANGE ZN	16	17	14215	MASTER LINK 50	1
4	14216	AXLE - 7150	1	18	14243	NUT, M10 X 1.25 LOCKING FLANGE ZN	8
5	14204	CHAIN:50 X 52P INC ML	1	19	14214	ASM, TIRE/WHL LR FAR EAST-7150	1
6	14205	SPROCKET, 50P 32T - 6150/7150	1	19a	14214A	ASM, TIRE/WHL LR SUN F-7150	1
7	14436	BOLT, M8 X 1.25 X 25 FHCS ZN	4	20	14248	SPACER, M16 X 16 X 4	2
8	14206	SEAL, M50 X 34 X 7 DUST	2	21	14249	NUT, M16 X 2.00 CASTLE	2
9	14207	HOUSING, AXLE BRG - 6150/7150	2	22	14213	PIN, M4 X 30 COTTER	2
10	14208	BEARING - 6206	2	23	14151	CAP, HUB NOSE - BLACK RUBBER	2
11	14209	FLANGE, BEARING - 6150/7150	2	24	14217	SPROCKET, 50P 16T - 6150/7150	1
12	14439	BOLT, M8 X 1.25 X 40 FHCS ZN	6	25	14218	KEEPER, SPROCKET - 6150/7150	1
13	14210	SEAL, M42 X 30 X 7 DUST	2	26	14296	BOLT, M6 X 1.00 X 12 FHCS ZN	2
14	14147	STUD, M10 X 1.25 X 31 WHEEL	8	27	14754	TIRE, 21 X 10-10 FAR EAST	2
15	14211	HUB, REAR WHEEL - 7150	2	28	14758	WHEEL, 10 X 4.75 4-165MM, SILVER	2

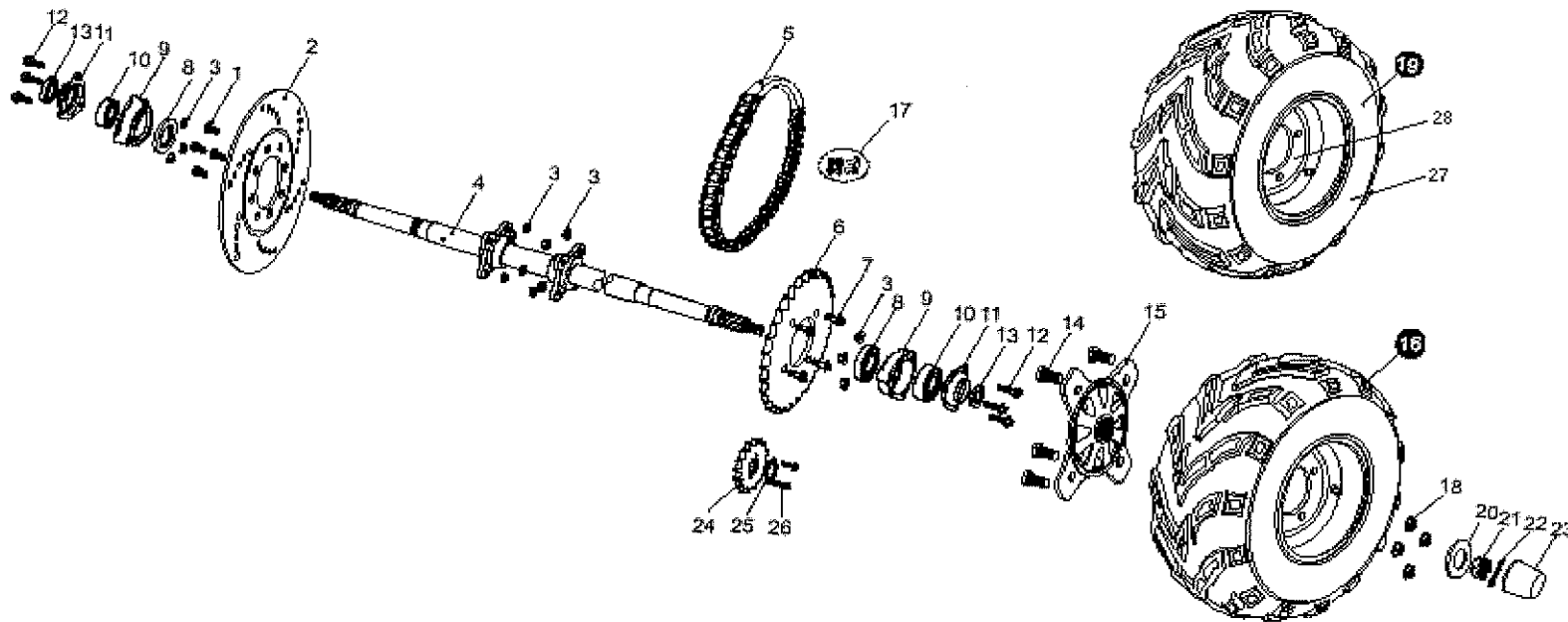

Section 25 - Electrical

Ref No	Part No	Description	QTY
1	14219	PANEL, DASH - 7150	1
2	14220	SWITCH, HEADLIGHT - 7150	1
3	14221	SWITCH, ENGINE STOP - 6150/7150	2
4	14222	SWITCH, KEYED IGNITION W/KEY - 6150/7150	1
5	14739	HARNES, MAIN WIRING - 7150	1
6	14486	HARNES, BATTERY - 150CC	1
7	14428	SCREW, M6 X 1.00 X 20 PHMS ZN	2
8	14236	NUT, M6 X 1.00 NYLOC FLANGE ZN	7
9	14224	REGULATOR, VOLTAGE - 6150/7150	1
10	14225	RELAY, STARTER - 6150/7150	1
11	14226	CDI - 6150/7150	1
11A	14572	CDI - 20MPH REV LIMITED - 150CC	1
12	14491	NUT, M5 X .75 NYLOC ZN	1
13	14425	BOLT, M5 X .75 X 25 PHMS ZN	1
14	14227	COIL, IGNITION W/CAP - 6150/7150	1
15	14487	COVER, DECORATIVE DASH BOLT - 7150	4
16	14418	SCREW, M4 X .75 X 10 PHMS ZN	4
17	14238	WASHER, M6 SPLIT LOCK ZN	4
18	14488	MAGNET, SPEED SENSOR - 7150	1
19	14228	SPEEDOMETER - 7150	1
20	14426	BOLT, M6 X 1.00 X 14 FHCS ZN	1
21	14229	BRACKET, SPEEDO SENSOR - 7150	1
22	14231	FUSE, 15AMP - WAYTEK 46115	2
23	14230	SENSOR, SPEEDO - 7150	1
24	14557	SCREW, M3 X 8 PAN HEAD	1
25	14419	SCREW, M4 X .75 X 20 PHMS ZN	1
26	14588	KEY SET - 6150/7150	1
27	14740	HARNES, SWINGARM WIRING - 7150	1
28	14821	NUT, M4 X 0.75 NYLOC ZN	4

