

# OPERATOR'S MANUAL

## SUPPLEMENT

Model No. 720L

### ⚠ WARNING:

Read Engine Owner's Manual, Vehicle Operator's Manual, and Supplement Carefully Before Operating Vehicle.

Parts List



### ORDERING PARTS

FAST & EASY!

- 1) Seek Part(s) from your models illustrated diagram, cross over REF# to PART#
- 2) Type PART# into sites [Search Box] at [GoKartsRus.com](http://GoKartsRus.com) TIP! - RIGHT CLICK LINK, SELECT OPEN IN NEW TAB
- 3) Add all needed parts to Shopping Cart | Complete "Checkout" | ✓ Done!

If a part does not come up in a Site Search, please [Contact Us](#) (include part# in email)

LOWEST PRICE!

## THIS VEHICLE IS FOR OFF-ROAD USE ONLY

BEFORE OPERATING THIS VEHICLE, THE OWNER AND/OR OPERATOR MUST UNDERSTAND THE VEHICLE WAS NOT DESIGNED OR MANUFACTURED TO MEET SPECIFICATIONS FOR USE ON STREETS, HIGHWAYS, OR THOROUGHFARES AND HAVE READ AND HAVE AN UNDERSTANDING OF ALL THE INSTRUCTIONS FOR SAFE ASSEMBLY AND OPERATION AS WELL AS THE INSTRUCTIONS GOVERNING THE ENGINE AND OTHER PORTIONS OF THE VEHICLE.

# PARTS LIST MODEL 720L

REF	PART#	DESCRIPTION
1	13535-29	FRAME - ULTRAMARINE BLUE
	13535-37	FRAME - RED WAGON
	13535-44	FRAME - MINERAL BRONZE
2	13537	REAR SWINGARM ASSY (INCL #15)
3	11954-2Z	RIGHT FRONT SWINGARM W/ZERK
<b>NI</b>	11955-2Z	LEFT FRONT SWINGARM W/ZERK
	11923-37	REAR BAR - RED WAGON
4	11923-40	REAR BAR - SPARKLE SILVER
	11923-44	REAR BAR - MINERAL BRONZE
	11925-37	OVERHEAD BAR - RED WAGON
5	11925-40	OVERHEAD BAR - SPARKLE SILVER
	11925-44	OVERHEAD BAR - MINERAL BRONZE
6	13603-2	SEAT FRAME - BLACK
7	9022	WASHER 1/2 STD FLAT ZINC
8	9188	BOLT 1/2-13 X 1.50 HHCS G5 ZINC
9	13503	NUT 1/2-13 CENTERLOCK HEX ZINC
10	1264	BOLT 1/2-13 X 3.75 HHCS G2 ZINC
11	10834	BOLT 1/2-13 X 7.00 HHCS G5 ZINC
12	1104	SPACER SPLIT .8120D .625ID 1.00L
14	13354	NUT 5/8-11 CL HEX ZINC
15	12140	BRONZE BUSHING .625 X 1.25
16	12141	SHOULDER BOLT 1/2 X 1.875
17	13191	FRONT WHEEL ASSEMBLY (INCLUDES 20)
18	5090	BEARING 5/8 ID 1-3/8 OD SNAP RING
19	13504	BOLT 1/2-13 X 1.00 HHCS G5 ZINC
20	13486	TIRE - 16 X 6.50-8 BADLAND
21	9674-16	SPACER 3/8 X 3/8 ZINC
22	11950-2Z	RIGHT SPINDLE W/ZERK - BLACK
<b>NI</b>	11951-2Z	LEFT SPINDLE W/ZERK - BLACK
23	12467	TIE ROD ASSEMBLY LONG (INCL. 25,26,28-30)
24	4355	TIE ROD ASSEMBLY SHORT (INCL. 25-27,29,30)
25	1414	RIGHT THREAD ROD END
26	9092	RIGHT JAM NUT 3/8-24
27	4352	TIE ROD 9.50 INCH
28	12466	TIE ROD 16.50 INCH
29	9024	LEFT JAM NUT 3/8-24
30	1415	LEFT THREAD ROD END
31	9158	BOLT 3/8-16 X 2.25 HHCS G5 ZINC

REF	PART#	DESCRIPTION
32	9146	BOLT 3/8-16 X 1.50 HHCS G5 ZINC
33	6293-16	BRAKE PEDAL
34	6309-16	THROTTLE PEDAL
35	1189	NUT 5/16-18 HEX TL ZINC
36	8655	SEAT SLIDE - PAIR
37	9176	BOLT 5/16-18 X 1.00 HHCS G5 ZINC
38	1447	SHOULDER BOLT 5/16-18 X 11/16THD
39	9091	WASHER FLAT 3/8 SAE N ZINC
41	1848	BOLT 1/4-20 X 1.25 HHCS G5 ZINC
42	1849	BOLT 1/4-20 X 1.50 HHCS G5 ZINC
43	1846	BOLT 1/4-20 X .750 HHCS G5 ZINC
44	1847	BOLT 1/4-20 X 1.00 HHCS G5 ZINC
45	1389	BUSHING .25ID X .031G X .313
46	9502	PEDAL SPRING - LEFT WOUND
47	9503	PEDAL SPRING - RIGHT WOUND
48	1854	WASHER NBR 14 FLAT MS ZINC
49	8251	THROTTLE CABLE (INCLUDES #50)
50	9058	NUT 5/16-24 HEX JAM
54	2388	NUT 3/8-24
55	C1001	HYDRAULIC BRAKE & MASTER CYLINDER ASSEMBLY
56	12496	STEERING WHEEL
<b>NI</b>	12481	STEERING WHEEL CAP
57	9103	BOLT 1/4-20 X 2.00 HHCS G2 ZINC
58	9057	NUT 1/4-20 TL ZINC
59	3818	CHAIN 420 X 80P (INCL #60)
60	2037	MASTER LINK 420
61	13190	REAR WHEEL ASSEMBLY (INCLUDES 62 & 65)
62	13488	TIRE - 22 X 11-8 BADLAND
64	G0725	LOOM 7.25L X 1.625OD
65	13302	WHEEL FLANGE ASSY - HEX
66	1428	NUT 1/2-20 CONE WHEEL
67	8227	NUT 1/2-20 CLIP
68	11387	LOOP CLIP 1.25ID
69	1876	BOLT 1/4-20 X .625 HH WF ZINC
71	2449	TINNERMAN NUT
72	13588	TOP COVER

REF	PART#	DESCRIPTION
73	13601	BOTTOM COVER
74	13336	TAV COVER ASSEMBLY
75	9929	BLACK VINYL CAP
76	8778	LAP/SHOULDER SEAT BELT
77	12015	SHOCK ABSORBER
78	9190	BOLT 3/8-16 X 3.25 HHCS G5 ZINC
79	9085	NUT 3/8-16 TL HEX ZINC
80	9192	NUT 3/8-16 HEX WF
81	8118	CHOKE CABLE
82	1263	NUT 5/16-18 HEX WF ZINC
83	11330	WARNING DECAL SHEET
84	12008	WARNING DECAL SHEET
86	11836	FLOOR PAN SCUFF DECAL
87	11636	BACK/BOTTOM SINGLE SEAT
88	8484	CLEVIS PIN 1/4 X 1.50
89	4372	HANDHOLD
90	9116	COTTER PIN 3/32 X .750 ZINC
91	9006	BOLT 1/4-20 X .50 HH WF
<b>WD</b>	13590	WIRING HARNESS
<b>WD</b>	13589	LIGHT & STOP SWITCH W/WIRING
<b>WD</b>	13097	REPLACEMENT - LIGHTS ONLY (PAIR)
<b>WD</b>	13096	REPLACEMENT - 35WATT BULB
<b>NI</b>	11081	10 AMP FUSE (USED IN RUN LIGHTS)
<b>WD</b>	12761	VOLTAGE REGULATOR
94	13303	BRAKE HUB
95	9099	BOLT 3/8-16 X 1
96	13331	M8 BOLT
97	13309-2	BRAKE LINK - BLACK
98	6442	BRAKE HANDLE COVER
99	9869	SPACER .25ID .3120D .625 BR
100	12018	RIGHT SIDE PANEL
<b>NI</b>	12019	LEFT SIDE PANEL
101	9145	BOLT 3/8-16 X 1.75 HHCS G5 ZINC
102	9125	WASHER FLAT 3/8 USS W ZINC
103	12039	FOAM 4.50 INCH BLACK
104	1019	CABLE TIE
105	12252	ENGINE - 10HP

# PARTS LIST MODEL 720L

REF	PART#	DESCRIPTION
<b>ASM</b>	2594	DRIVER PULLEY (INCLUDES 106 - 114)
106	**	COVER AND DRIVE PLATE
107	2472	EXTENSION SPRING
108	2470	CAM ROLLER
109	2471	SPRING CLIP
110	**	MOVEABLE FACE AND HUB
111	2474	GUIDE BUSHING
112	2475	COMPRESSION SPRING
113	**	RETAINING RING
114	**	FIXED FACE AND POST
<b>ASM</b>	8664	DRIVEN PULLY (INCLUDES 115, 117-123)
115	**	FIXED FACE AND POST
117	2483	SPACER
118	**	MOVEABLE FACE AND CAM
119	2516	BUTTON INSERT
120	2480	TORSION SPRING
121	**	FIXED CAM
122	2478	THRUST WASHER
123	2477	RETAINING RING
124	1466	NUT 5/8-11 FLEXLOCK JAM
125	9101	BOLT 5/16-24 X .50 HHCS G5 NL ZINC
126	12350	BOLT STUD 7/16-20 X 4.25 G5 ZINC
127	2467	WASHER 7/16 SL
128	2468	PILOT WASHER
129	8720	SPROCKET 420P 9T INTEGRAL KEY
130	3403	KEY 3/16 SQ X 2.000
131	1119	SPACER .625ID 1.062OD .125 THK
132	1082	SPACER 1.00ID 14G .438L ZINC SPLIT
133	11808	BLACK VINYL CAP
134	13079-2	COVER PLATE - BLACK
136	3887	SPACER - 1.0 ID X 1/16
137	12346	DRIVE BELT
138	13078-2	TAV CHASSIS WDMT - BLACK
139	2430	SPANNER 5/8 ID X 7-1/8 - 14 GA
140	8854	JACKSHAFT - 13.688
141	12349	ENGINE SUPPORT SPACER ASSEMBLY

REF	PART#	DESCRIPTION
142	13298	AXLE
143	C1010	BRAKE ROTOR - 8.63 X .156
145	9060	WASHER 5/16 TYPE A PLAIN SAE N ZINC
146	2265-16	SPACER 1.00ID 12G .750L ZINC
147	13299	BEARING PRECISION - HEX
148	13300	BEARING FLANGE HEAVY
149	1194	WASHER 3/4 SAE FLAT ZINC
150	13355	NUT 3/4-10 HEX CENTERLOCK ZINC
151	9338	SPROCKET 420P 60T
152	13301	HEX SPROCKET HUB
153	6701	BOLT 5/16-18 X 1.25 SHCS PLAIN
154	11928-37 11928-40 11928-44	CENTER BAR - RED WAGON CENTER BAR - SPARKLE SILVER CENTER BAR - MINERAL BRONZE
155	6320	HEADREST - SINGLE
156	5447	SAFETY FLAG - 6 FT
157	12016-2	HEADREST FRAME - BLACK
169	11361	FLAG MOUNTING BOLT
170	6452	BOLT 3/8-16 X 5.00 HHCS G5 ZINC
171	2386	BOLT 3/8-16 X 3.50 HHCS G5 ZINC
172	13617-2	STEERING PIVOT LEVER -BLACK
173	13522	IMPELLER
174	8604	NUT 7/16-20 HEX
175	8402	NUT 7/16-20 TL HEX
176	9430	BATTERY HOLD DOWN ROD
177	9468	NUT NBR 10-32 NL WING
178	9642-2	BATTERY CLAMP BAR - BLACK
179	13324	BATTERY
<b>NI</b>	12149	BATTERY BOOT - RED
<b>NI</b>	12150	BATTERY BOOT - BLACK
<b>WD</b>	3610	BATTERY CABLE BLACK 9IN
<b>WD</b>	12351	WIRING DIAGRAM
180	6803-2	CONTROL PANEL COVER - BLACK
181	5135	TINNERMAN NUT
182	6046	BOLT NBR 10-24 X .500 HHMS ZINC
183	6039	WASHER NBR 10 IL ZINC
184	13456	BOLT 3/8-24 X 1.00 HHCS GR5 NL
186	12348	RETURN SPRING

REF	PART#	DESCRIPTION
187	12347	SWIVEL SCREW
188	9030	LOCKWASHER 5/16
189	13619-2	BRAKE ROD LONG - BLACK
190	C1000	RACK AND PINION
191	1130	WASHER 3/8 SL
192	13454-2	STEERING LINK BRACKET - BLACK
193	200841	FENDER WASHER
194	13344-16	SPACER - 1.25ID X 12G X 5.00 - ZINC
195	13604	BRAKE CABLE
<b>WD</b>	13631	20 AMP FUSE (USED ON VOLTAGE REG)

**ASM** = ASSEMBLY

**NI** = NOT ILLUSTRATED

**WD** = WIRING DIAGRAM

\*\* = NOT SOLD SEPERATELY



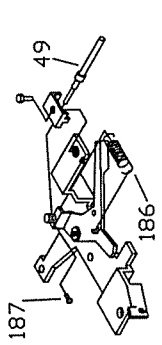

THROTTLE LINKAGE DETAIL

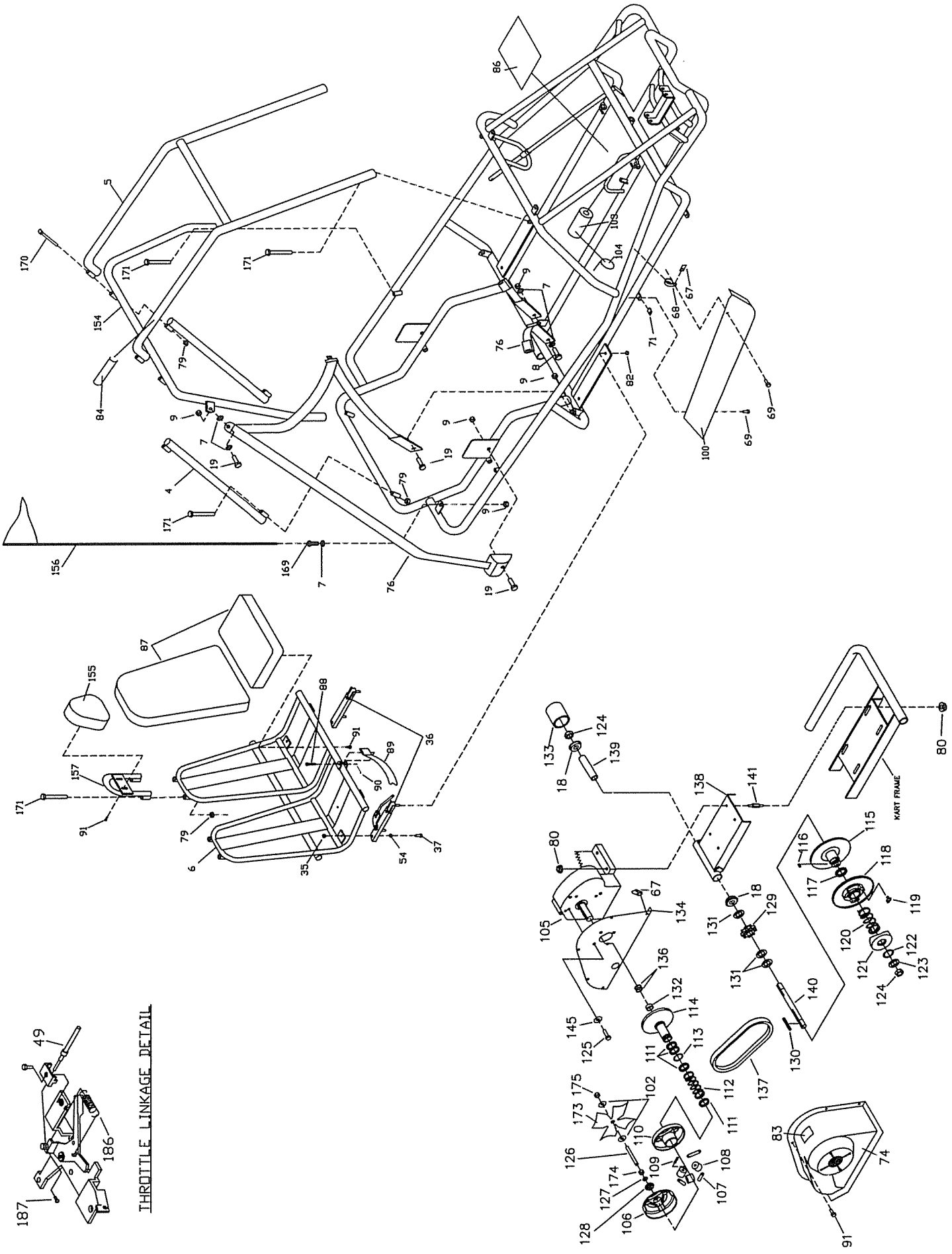

Torque Converter Drive Breakdown

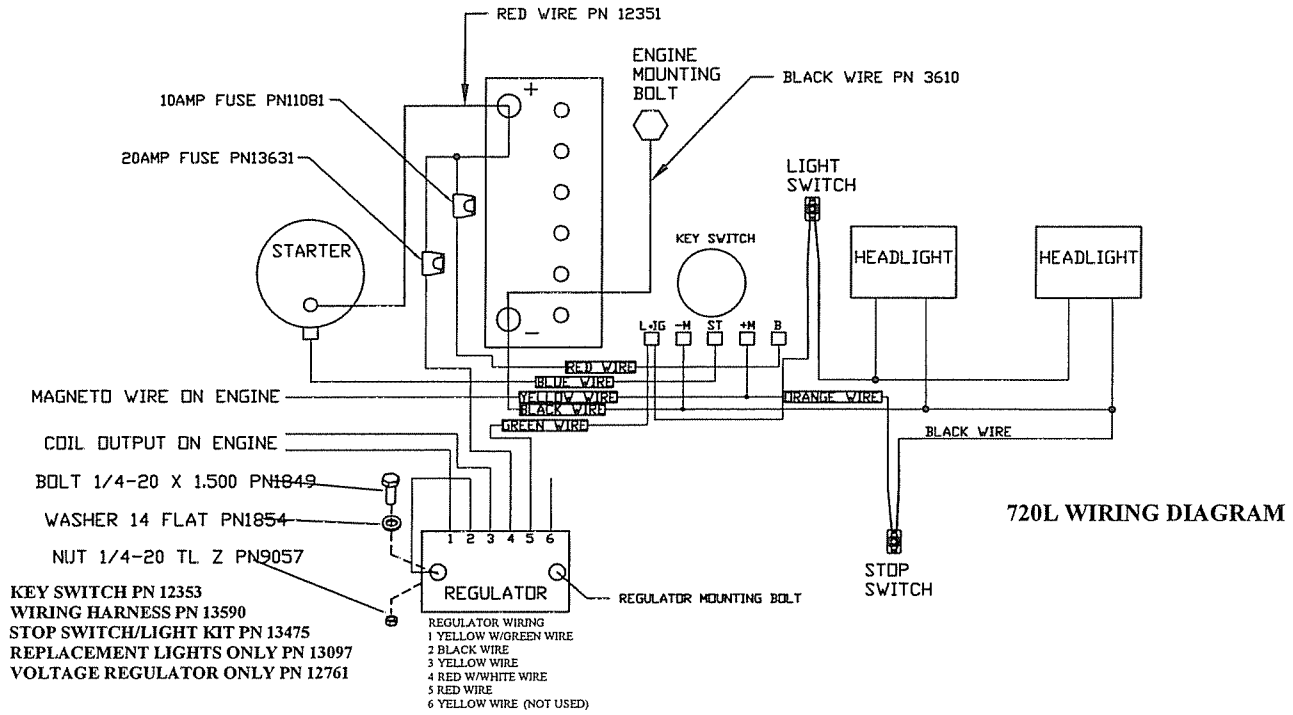

## 720 MAINTENANCE INSTRUCTIONS

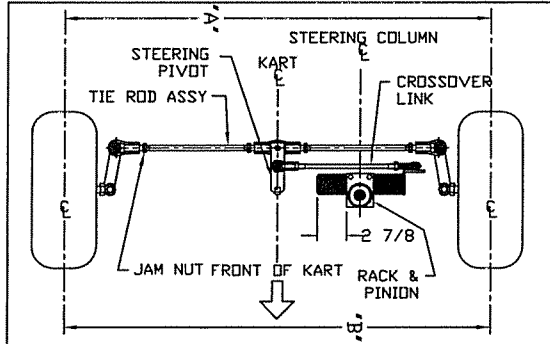

**STEERING ALIGNMENT INSTRUCTIONS**

- 1) LOOSEN ALL TIE ROD NUTS
- 2) ROTATE STEERING WHEEL SUCH THAT DIMENSION FROM THE END OF THE RACK AND PINION TO THE RACK AND PINION BODY IS 2 7/8". REF ABOVE DIAGRAM
- 3) ADJUST THE CROSSOVER LINK SUCH THAT THE STEERING PIVOT RUNS PARALLEL TO THE CENTERLINE OF THE KART AS SHOWN
- 4) TIGHTEN CROSS OVER LINK JAM NUTS
- 5) ADJUST RH AND LH TIE ROD ASSEMBLIES SUCH THAT DIMENSION "A" IS 3/8"-1/2" LONGER THAN DIMENSION "B"
- 6) RETIGHTEN RH AND LH TIE ROD JAM NUTS

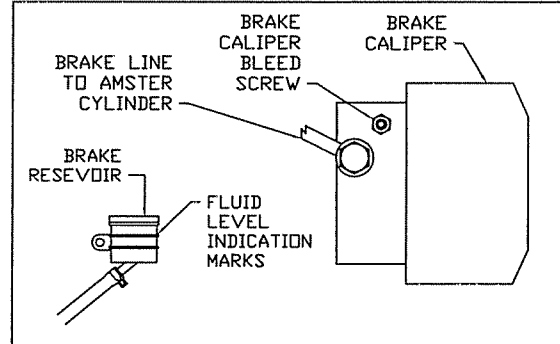

**BRAKE BLEED/ADJUSTMENT INSTRUCTIONS**

- 1) INSPECT FLUID RESEVOIR BEHIND SEAT ENSURE THAT THE FLUID LEVEL IS BETWEEN THE INDICATION MARKS
- 2) ADD DOT 3 BRAKE FLUID IF REQUIRED
- 3) UNCAP AND LOOSEN BRAKE CALIPER BLEED SCREW
- 4) HAVE A SECOND PERSON DEPRESS THE BRAKE PEDAL SLOWLY UNTIL THE PEDAL BOTTOMS OUT
- 5) HOLD THE PEDAL IN THE DEPRESSED POSITION UNTIL THE BLEED SCREW IS RETIGHTENED
- 6) PUMP THE BRAKE PEDAL TWO TO THREE TIMES AND REPEAT PROCEDURE UNTIL THE PEDAL FEELS FIRM DURING THE PEDAL STROKE
- 7) AIR BUBBLES SHOULD BE SEEN AT THE BLEED SCREW DURING THE BLEED PROCEDURE UNTIL PEDAL BECOMES FIRM
- 8) TIGHTEN AND RECAP THE BLEED SCREW