

# OPERATOR'S MANUAL SUPPLEMENT

Model No. 724 – 4.0HP Stock Kar  
725 – 5.0HP Stock Kar

## ⚠ WARNING:

Read Engine Owner's Manual, Vehicle Operator's Manual, and Supplement Carefully Before Operating Vehicle.

Parts List



## ORDERING PARTS

FAST & EASY!

- 1) Seek Part(s) from your models illustrated diagram, cross over REF# to PART#
- 2) Type PART# into sites [Search Box] at [GoKartsRus.com](http://GoKartsRus.com) TIP! - RIGHT CLICK LINK, SELECT OPEN IN NEW TAB
- 3) Add all needed parts to Shopping Cart | Complete "Checkout" | ✓ Done!

If a part does not come up in a Site Search, please [Contact Us](#) (include part# in email)

LOWEST PRICES!

# THIS VEHICLE IS FOR OFF-ROAD USE ONLY

BEFORE OPERATING THIS VEHICLE, THE OWNER AND/OR OPERATOR MUST UNDERSTAND THE VEHICLE WAS NOT DESIGNED OR MANUFACTURED TO MEET SPECIFICATIONS FOR USE ON STREETS, HIGHWAYS, OR THOROUGHFARES AND HAVE READ AND HAVE AN UNDERSTANDING OF ALL THE INSTRUCTIONS FOR SAFE ASSEMBLY AND OPERATION AS WELL AS THE INSTRUCTIONS GOVERNING THE ENGINE AND OTHER PORTIONS OF THE VEHICLE.

## PARTS LIST FOR 4HP & 5HP STOCK KARS

REF	PART #	DESCRIPTION
1	5280-2	FRAME - BLACK
<b>ASM</b>	4355	TIE ROD ASSEMBLY (INCLUDES 2 - 6)
2	4352	TIE ROD 9.50 INCH
3	1415	TIE ROD END - LEFT THREAD
4	9024	NUT 3/8-24 LEFT THREAD JAM
5	1414	TIE ROD END - RIGHT THREAD
6	9092	NUT 3/8-24 HEX JAM ZINC
7	10374	WH ASM 5IN STL WH 4.10 X 3.50 SLK (INCLUDES 9 & 10)
8	5090	BEARING 5/8ID X 1-3/8OD SNAP RING
9	1753	TUBE 4.10/3.50 X 5
10	6035	TIRE 4.10/3.50 X 5 SLICK
11	12347	ENGINE SWIVEL SCREW
12	12348	ENGINE RETURN SPRING
13	9085	NUT 3/8-16 TOPLOCK HEX ZINC
<b>ASM</b>	10991	DRIVE WHEEL ASSY - 5IN STEEL (INCLUDES 8, 13, 14, 16 - 21)
14	10375	WH ASM 5IN STL DR WH 4.10 X 3.50 SLK
16	8007	SPROCKET SA 35P 60T
17	8409	NUT 1/2-20 HEX ZINC
18	1246-16	BRAKE DRUM 4IN - ZINC
19	9158	BOLT 3/8-16 X 2.25 HHCS G5 ZINC
20	9169	NUT 1/2-20 HEX JAM ZINC
21	9091	WASHER 3/8 FLAT SAE N ZINC
22	8021-2Z	RIGHT SPINDLE WITH GREASE ZERK
<b>NI</b>	8020-2Z	LEFT SPINDLE WITH GREASE ZERK
23	8252	THROTTLE CABLE 61INCH (INCLUDES 95)
24	6293-16	BRAKE PEDAL - ZINC
25	6309-16	THROTTLE PEDAL - ZINC
<b>NI</b>	9929	VINYL CAP .25 X .25 (PEDAL STOPS)
26	9945-2	FRONT BRAKE ROD - BLACK
27	9946-2	REAR BRAKE ROD - BLACK
28	1036	BRAKE BAND - 4INCH
<b>ASM</b>	9799	STOP SWITCH ASSEMBY (INCLUDES 29)
29	1392	TOGGLE SWITCH
32	12273	WIRE HARNESS
33	1976	SEAT
34	4399-2	SEAT FRAME - BLACK
35	12246	ENGINE - 4HP ROBIN
	12247	ENGINE - 5HP ROBIN
<b>ASM</b>	4335	CLUTCH ASSY (INCLUDES 36 -40)
36	4496	CLUTCH CENTER - SGL SPROCKET
37	3146	FIBER WASHER
38	4491	DRUM W/SPROCKET (INCLUDES 39)
39	3143	BEARING
40	3141	SNAP RING
41	1124	WASHER 5/16 SL ZINC
42	1491	BOLT 5/16-24 X .750 HHCS G5 ZINC
43	6573	BOLT 5/16-18 X 1.75 HHCS G5 ZINC (4HP MDL)
	9186	BOLT 5/16-18 X 1.50 HHCS G5 ZINC (5HP MDL)
44	9101	BOLT 5/16-24 X .50 HHCS G5 NYLOCK Z
45	1398	BUSHING .25ID X .031G X .313
46	9030	WASHER 5/16 IL ZINC
46A	9030	WASHER 5/16 IL ZINC (4 per 4HP ONLY)
47	3363-2	CHAIN GUARD MTG. BRACKET
48	5135	TINNERMAN NUT

REF	PART #	DESCRIPTION
49	PX2340 1194	BUSHING MACH .75ID X.125 (1 per 4HP) WASHER 3/4 SAE FLAT ZINC (2 per 5HP)
50	9788 6073	CHAIN 35 X 58P W/MSTRLINK (4HP ONLY) CHAIN 35 X 72P W/MSTRLINK (4HP & 5HP)
51	1269	MASTER LINK 35
52	9734 3362	CHAINGUARD COVER - 4HP CHAINGUARD COVER - 5HP
53	6038	STEERING WHEEL
54	9709	COMPRESSION SPRING
55	1019	CABLE TIE - 7INCH
56	1046	NUT 5/8-11 TOPLOCK HEX ZINC
57	1264	BOLT 1/2-13 X 3.75 HHCS G2 ZINC
58	1012	NUT 1/2-13 TOPLOCK HEX ZINC
59	9110	SHOULDER BOLT 5/16-18 X 5/8 THRD
60	9091	WASHER FLAT 3/8 SAE N ZINC
61	1189	NUT 5/16-18 TOPLOCK HEX ZINC
62	1263	NUT 5/16-18 HEX WHIZ FLANGE ZINC
63	1846	BOLT 1/4-20 X .750 HHCS G5 ZINC
65	1847	BOLT 1/4-20 X 1.00 HHCS G5 ZINC
66	1849	BOLT 1/4-20 X 1.50 HHCS G5 ZINC
67	9502	PEDAL SPRING - LEFT WOUND
68	9503	PEDAL SPRING - RIGHT WOUND
69	9057	NUT 1/4-20 TOPLOCK ZINC
70	1854	WASHER NBR 14 FLAT ZINC
71	9118	CLEVIS PIN 1/4 X 1.250 ZINC
72	1389	BUSHING .25ID X .031G X .313
73	9116	COTTER PIN 3/32 X .750 Z
74	6046	BOLT NBR 10-24 X .50 HHMS ZINC
75	6039	WASHER NBR 10 IL ZINC
76	9145	BOLT 3/8-16 X 1.75 HHCS G5 ZINC
77	9146	BOLT 3/8-16 X 1.50 HHCS G5 ZINC
78	9085	NUT 3/8-16 TOPLOCK HEX ZINC
80	11330	DECAL SHEET - WARNINGS
82	10465	SIDE PANEL
85	1119	SPACER .625ID 1.062OD
86	1119	SPACER .625ID 1.062OD (4 per 5HP)
88	1982-2	PEDAL LATCH - BLACK
91	9103	BOLT 1/4-20 X 2.00 HHCS G2 ZINC
92	9080	BOLT 1/4-20 X 2.75 HHCS G2 ZINC
93	9160	BOLT 1/4-20 X .875 HHCS NYLOCK G5 ZINC
94	5839	BOLT 1/4-20 X .750 HHCS WHIZ FLANGE Z
95	9058	NUT 5/16-24 HEX JAM ZINC
97	4943-2	BODY SUPPORT TUBE - BLACK
98	BODY	SPECIFY COLOR
99	3463	RUBBER WASHER 1/4
102	9796	BOLT NBR 12-24 X .500 SELF TAPPING Z
103	1463	BLACK INSULATING BUSHING
104	9104	WASHER NBR 10 FLAT ZINC
<b>NI</b>	6985	SEAT SLIDE KIT (5HP MODEL ONLY)
<b>NI</b>	8778	SEAT BELT (5HP MODEL ONLY)

**NI** = NOT ILLUSTRATED  
**ASM** = ASSEMBLY

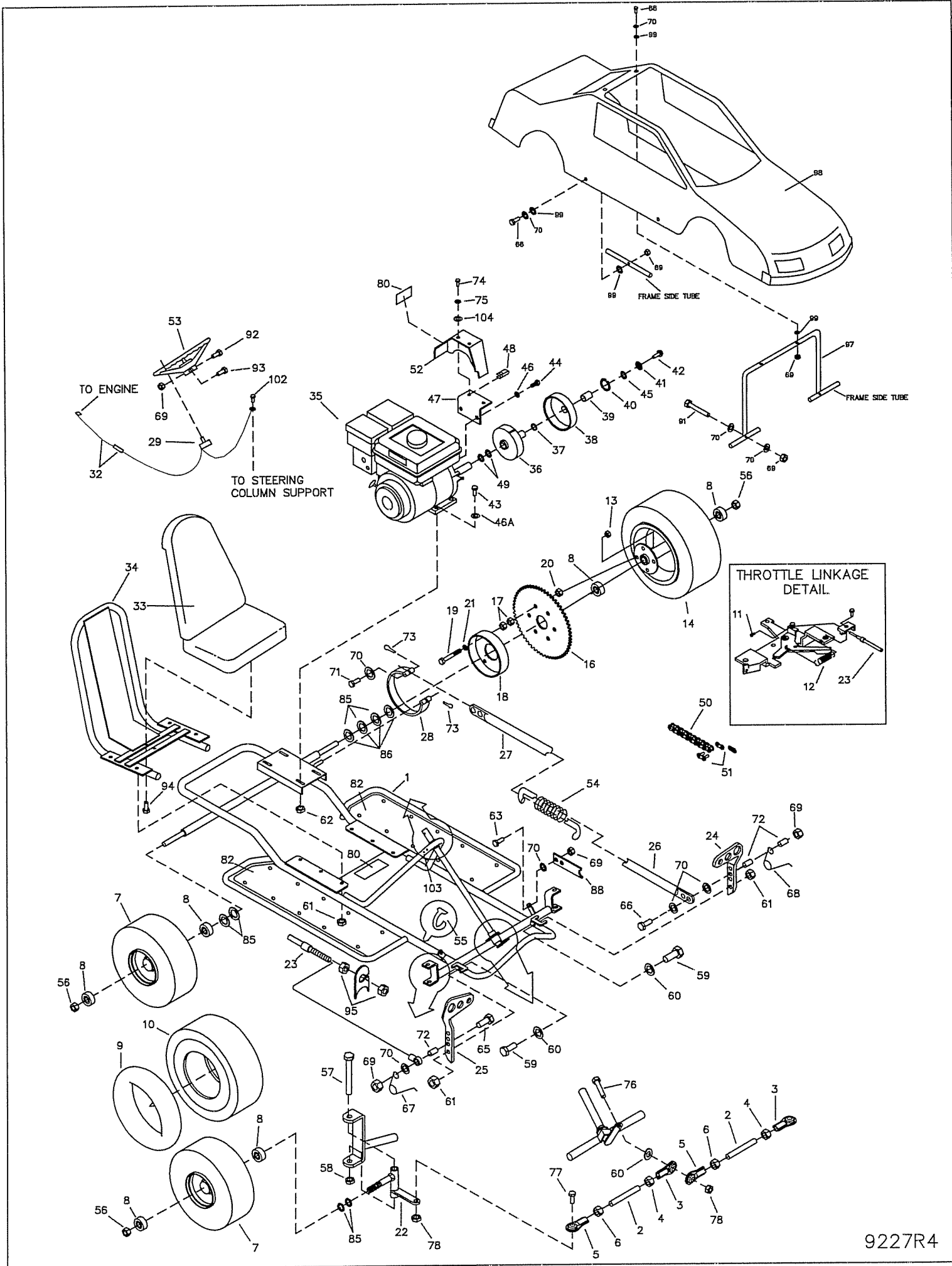

# 4HP MODEL ONLY

SPEED REDUCER		
REF NO	PART NO	DESCRIPTION
1	1136	NUT 5/8-18 CL HEX JAM Z
2	5090	BEARING 5/8 ID 1-3/8 OD SNAP RING
3	6568	SPANNER 5/8 ID X 3-7/8 LG 11GA
4	2385	BOLT 3/8-16 X 4.000 FULL THRD HHCS G2 Z
5	1128	NUT 3/8-16 HEX Z
6	6563	JACKSHAFT 5/8 X 8.500
7	1119	SPACER .625ID 1.062OD .125THK Z
8	6570	SPROCKET 35P 26T .625IN ID
9	1031	KEY 3/16SQ X .500L
10	3504	SPROCKET DR 35P 12T .625IN ID
11	6558-2	SPEED REDUCER CHASSIS GLBLK

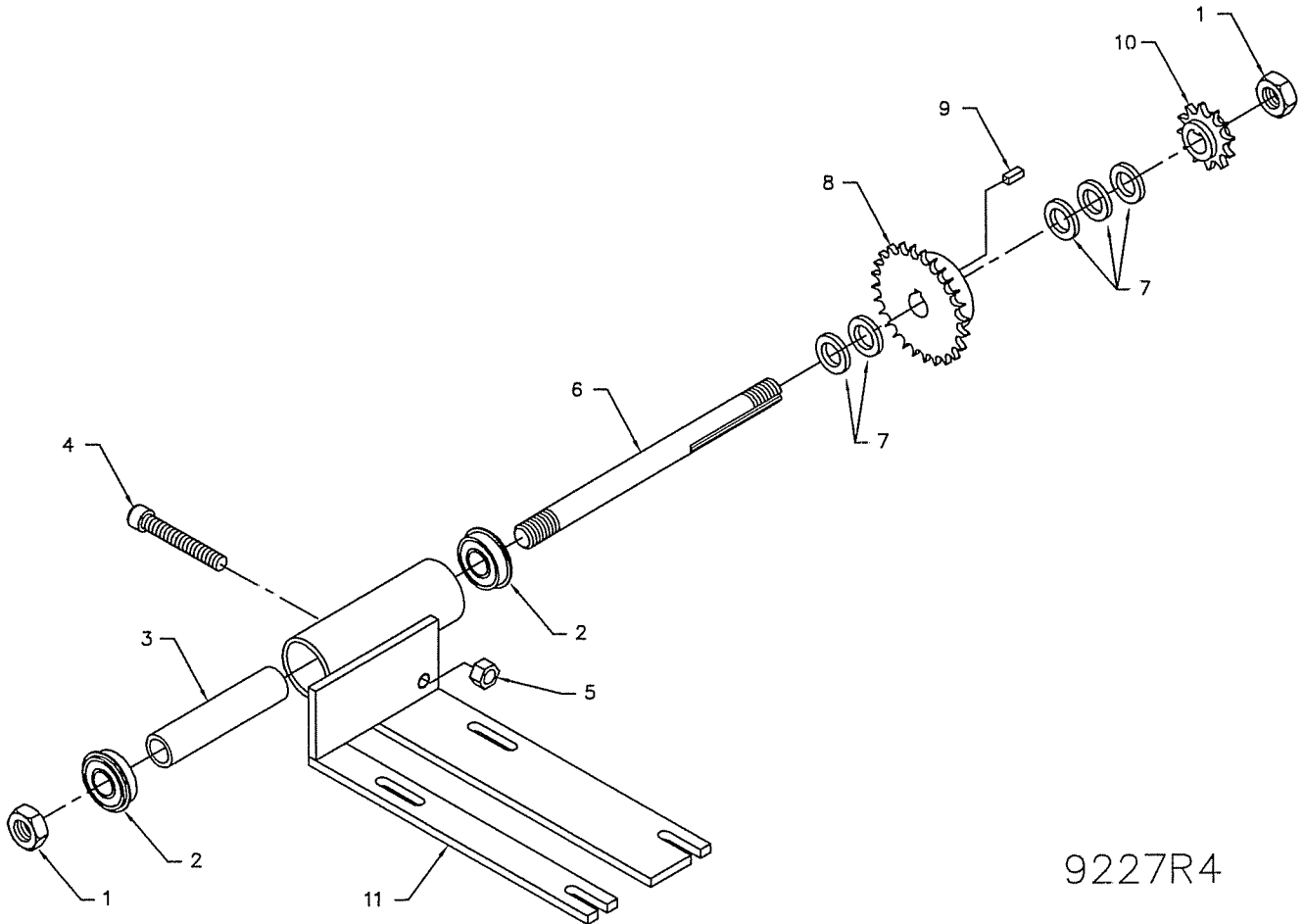

9227R4

# 5HP MODEL ONLY

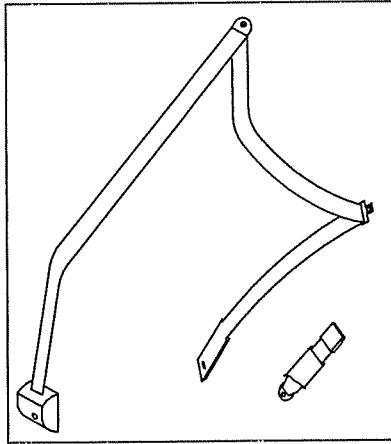

**MARCO**  
PowerSports

4404 Engle Ridge Drive, Fort Wayne, IN 46804  
Tele: (260)432-1596 Fax: (260)432-7870

