

# Operator's Manual SUPPLEMENT

MANCO MODEL NO.  
808-00

**WARNING:**  
Read Engine  
Owner's Manual,  
Vehicle Operator's  
Manual, and  
Supplement  
Carefully Before  
Operating  
Vehicle.

Parts List



## ORDERING PARTS

FAST & EASY!

- 1) Seek Part(s) from your models illustrated diagram, cross over REF# to PART#
- 2) Type PART# into sites [Search Box] at [GoKartsRus.com](http://GoKartsRus.com) TIP! - RIGHT CLICK LINK, SELECT OPEN IN NEW TAB
- 3) Add all needed parts to Shopping Cart | Complete "Checkout" | ✓ Done!

If a part does not come up in a Site Search, please [Contact Us](#) (include part# in email)

LOWEST PRICES!

BEFORE OPERATING THIS VEHICLE, THE OWNER AND/OR OPERATOR MUST UNDERSTAND THE VEHICLE WAS NOT DESIGNED OR MANUFACTURED TO MEET SPECIFICATIONS FOR USE ON PUBLIC ROADS, STREETS, HIGHWAYS, OR THOROUGHFARES AND HAVE READ AND HAVE AN UNDERSTANDING OF ALL THE INSTRUCTIONS FOR SAFE ASSEMBLY AND OPERATION AS WELL AS THE INSTRUCTIONS GOVERNING THE ENGINE AND OTHER PORTIONS OF THE VEHICLE.

## REPAIR PARTS - 808-00

REF. NO.	PART NO.	DESCRIPTION	REF. NO.	PART NO.	DESCRIPTION
1	<del>8325-2</del>	Frame	69	—	
2	8341	Tie Rod, 23 inch	70	—	
3	3224	Tie Rod, 8-3/4 inch	71	—	
4	1414	Rod End - RH	72	—	
5	1415	Rod End - LH	73	—	
6	9092	Nut, 3/8-24 RH Jam	74	—	
7	9094	Nut, 3/8-24 LH Jam	75	9503	Spring, Right Wound
8	9145	Bolt, 3/8-16 x 1-3/4"	76	9502	Spring, Left Wound
9	9085	Nut, 3/8-16 Toplock	77	1436	Brake Pedal
10	8448	Compression Spring	78	6309	Throttle Pedal, Trimmed
11	2457	Spindle, Right	79	9345	Throttle Cable
NI	2458	Spindle, Left	80	8326-2	Seat Frame Weldment
12	8453	Bolt, 1/2-13 x 6-1/2"	81	6722	Seat Slide Pair
13	1012	Nut, 1/2-13 Toplock	82	2264	Bolt, 5/16-18 x 3/4"
14	4915	Tire, 145/70 x 6 Knobby	83	8437	Seat Back/Bottom
15	3802	Inner Tube, 6"	84	6038	Steering Wheel
16	1046	Nut, 5/8-11 Toplock	85	9080	Bolt, 1/4-20 x 2-3/4"
17	5090	Bearing, 5/8 ID	86	1689	Decal, Steering Wheel
18	9309FP	Wheel Assembly, Front (incl. 14-19)	87	6394	Stop Switch Assembly
19	5950	Spanner, 5/8 ID x 2-1/8"	88	4504	Decal, Yellow Warning
20	5157	Spacer, 5/8 ID x 3/4"	89	8153	Decal, Age Restriction
21	8327	Axle Weldment - Short	90	8399	Decal, Seat Belt Warning
22	8328	Axle Weldment - Long	91	1848	Bolt, 1/4-20 x 1-1/4"
23	6314	Brake Rotor	92	9869	Spacer, 1/4 ID x 5/16 OD x 5/8"
24	4914	Spacer, 1" ID x 9/16"	93	8416	Decal, Floor Pan
25	8462	Spacer, 1" ID x 2-3/4"	94	1441	Decal, Front Floor Pan
26	4662	Spacer, 1" ID x 4-1/4"	95	—	
27	4659	Spacer, 1" ID x 3-3/4"	96	—	
28	6617	Bearing Flange	97	—	
29	3941	Bearing, 1" ID	98	—	
30	PX2970	#9 Machinery Bushing	99	—	
ASM	8344	Differential/Sprocket Asm. (incl. 31-38)	100	—	
31	6819	Sprocket - 54 Tooth	101	5839	Bolt, 1/4-20 x 3/4" Flanged Whiz
32	1189	Nut, 5/16-18 Toplock	102	1447	Pedal Bolt
33	9186	Bolt, 5/16-18 x 1-1/2 GR5	103	9091	Washer, 3/8 Flat
34	—	Housing w/ Bearing	104	8138	Decal, Warning: Long Hair
35	—	Pinion Shaft	105	6540	Decal, Warning: Wear Helmet
36	—	Pinion Shaft Plug	106	9343	Chain, 420 x 71 Links plus Master Link
37	—	Pinion Gear	107	2037	Master Link, 420 Chain
38	—	Bevel Gear	108	9527-2	Rear Bar
39	—	—	109	8321-2	Center Bar
40	1775	Key, 1/4 sq. x 1-1/4"	110	8322-2	Front Bar
41	K810-00	Axle Guard Kit	111	8320-2	Overhead Bar
42	1557	Wheel Hub w/Studs	112	<del>8428</del>	Arm Pad Cover 8599
43	6123	Key, 1/4 sq. x 1-3/4"	113	9759B	Foam, 30" Black
44	1428	Nut, 1/2-13 Cone Wheel	114	9762B	Foam, 20" Black
ASM	1412	Wheel Asm, Rear (incl. 45-47)	115	9758B	Foam, 43" Black
45	1451	Wheel Rim, 8"	116	8463	Spacer, 1" ID x 2.625"
46	1430	Inner Tube, 8" (Repair Part Only)	117	6320	Headrest
47	1452	Tire, 22 x 11 - 8 Tubeless	118	9777	Plastic Hose Clamp, 7/8" ID
48	9162	Nut, 3/4-10 Toplock	119	1876	Bolt, 1/4-20 x 5/8" Flanged Whiz
49	9176	Bolt, 5/16-18 x 1"	120	2386	Bolt, 3/8-16 x 3-1/2"
50	6573	Bolt, 5/16-18 x 1-3/4"	121	6452	Bolt, 3/8-16 x 5"
51	9674	Spacer, 3/8 ID x 3/8"	122	6395-2	Front Plate
52	8331-2	Brake Link Weldment	123	6193	Nut, #10-32 Acorn
53	9455	Spring Pin	124	8419	Decal, Front Plate
54	9780	Extension Spring	125	—	
55	8197	Brake Calliper, Left	126	—	
NI	8444	Brake Calliper, Right	127	—	
56	6747	Brake Cable	128	—	
57	8343-2	Cable Extension	129	6773-2	Parking Brake Handle
58	9174	E-Ring	130	6442	Brake Handle Cover
59	1847	Bolt, 1/4-20 x 1"	131	1849	Bolt, 1/4-20 x 1-1/2"
60	9057	Nut, 1/4-20 Toplock	132	9172	Bolt, 3/8 x 1/4 Shoulder
61	1854	Washer, No. 14 Flat	133	6441	Washer, 3/8 ID Spring
62	1389	Bushing, 1/4" ID x 5/16	134	8330-2	Brake Rod
63	9160	Bolt, 1/4-20 x 7/8"	135	6440	Nut, 5/16-18 Jam
64	9146	Bolt, 3/8-16 x 1-1/2"	NI	9247R4	Assembly Instructions
65	—	—	NI	6477	Dingo Operator's Manual
66	—	—	NI	8220	Tecumseh Engine Manual
67	—	—			
68	—	—			

ASM = Assembly

NI = Not Illustrated

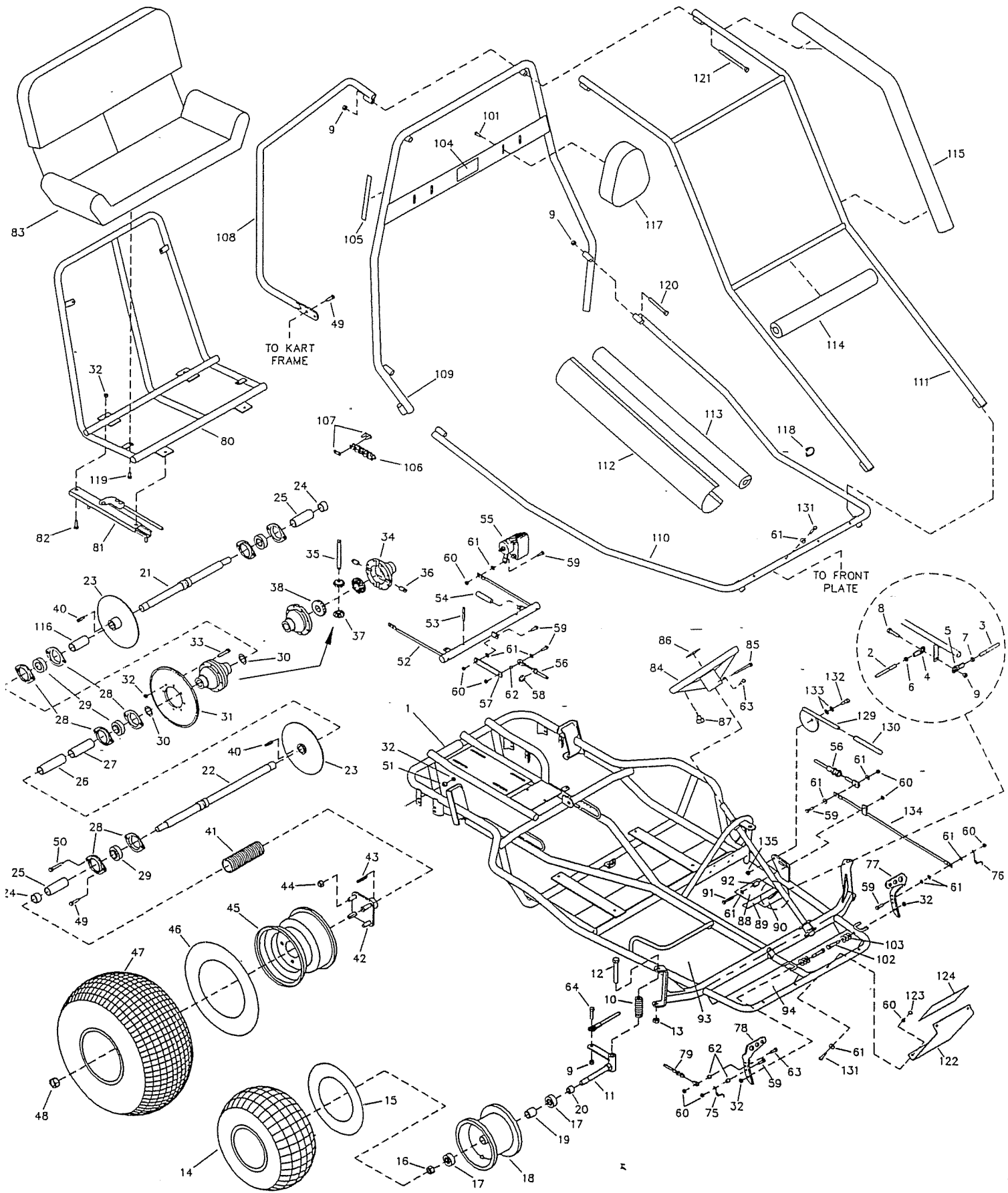

### CALIPER BREAKDOWN

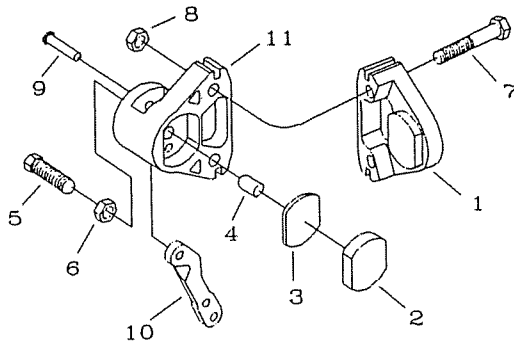

NO	NO	DESCRIPTION
ASM	8197	Brake Caliper (incl. 1-11) <i>includes pads</i>
ASM	9810	Brake Pad Svc Kit (incl. 1-3)
1	*	Anvil w/Lining
2	*	Brake Lining
3	3928	Backing Plate
4	3930	Actuator Pin
5	3931	Adjuster Pin
6	3932	Nut, Jam
7	9158	Bolt, 3/8-16 x 2-1/4"
8	9085	Nut, 3/8-16 Toplock
ASM	6534	MB-1 Service Kit (incl. 9-11)
9	*	Groove Pin
10	*	Lever
11	*	Brake Housing

8444 → Right Brake Caliper includes 1-11

### TORQUE CONVERTER BREAKDOWN

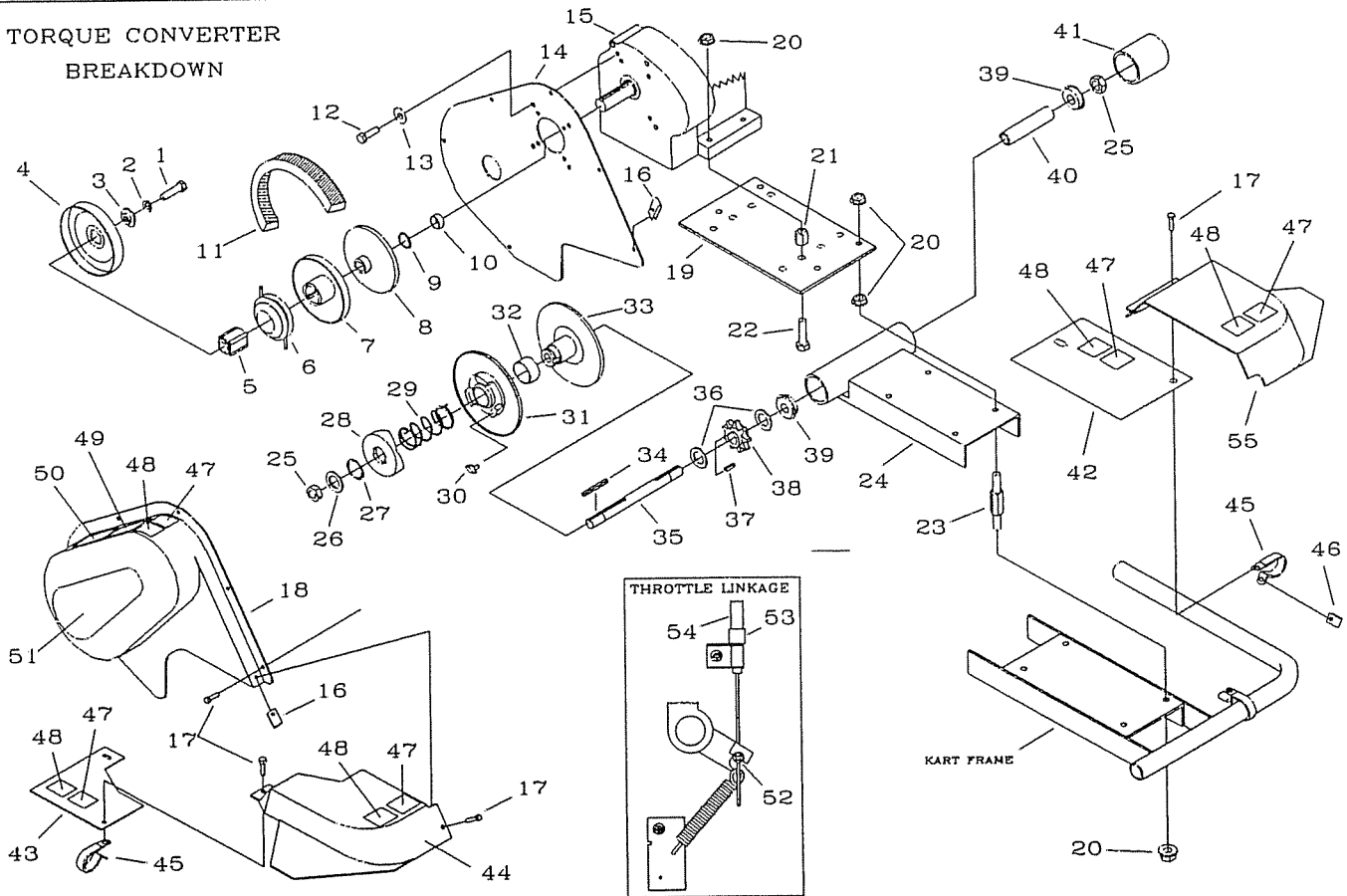

REF. NO	PART NO	DESCRIPTION	REF. NO	PART NO	DESCRIPTION	REF. NO	PART NO	DESCRIPTION
1	8203	Bolt, 3/8-24 x 1-3/4"	21	8206	Nut, 1/2-20 High	41	8194	Cap, Plastic
2	1130	Washer, 3/8 Split Lock	22	9127	Bolt, 5/16-18 X 2-1/4"	42	8443	Right Deck Cover
3	2468	Washer, Pilot	23	8205	Stud	43	8442	Left Deck Cover
ASM	8190	Driver Pulley Assembly (incl. REF. 4-8)	24	8209-2	Chassis	44	8440	Caliper Cover - Left
4	*	Drum	25	9155	Nut, 5/8-11 Jam	45	8266	Loop Clip
5	*	Hub	26	8193	Washer, Cup	46	8227	Clip Nut
6	*	Shoe Assembly	ASM	8191	Driven Pulley Assembly (incl. REF. 27-33)	47	1049	Decal, Caution
7	*	Moveable Sheave	27	2477	Retaining Ring	48	4912	Decal, Warning: Guard
8	*	Stationary Sheave	28	*	Cam	49	8138	Decal, Warning: Entanglement
9	3887	Spacer, 1" ID x 1/16	29	6805	Spring	50	6958	Decal, Tire Pressure
10	4914	Spacer, 1" ID x 9/16	30	6804	Button, Nylon	51	8225	Decal, TAV Cover
11	8192	Belt, Asymmetrical	31	*	Moveable Sheave	NI	9677	Decal, Warning: Hot Surfaces
12	9101	Bolt, 5/16-24 x 1/2"	32	*	Bushing	NI	9678	Decal, Warning: Eng. Exhaust
13	9060	Washer, 5/16 Plain	33	*	Stationary Sheave	NI	5964	Decal, Oil Warning
14	8200	Cover Panel	34	3403	Key, 3/16sq x 2"	<b>Throttle Linkage Illustration</b>		
15	8196	Engine, 8hp Tecumseh	35	8219	Jackshaft	52	1018	Cable Stop and Swivel Screw
16	2449	Nut, Tinnerman	36	1119	Spacer, 5/8ID x 1/8"	53	1628	Cable Retainer
17	9006	Bolt, 1/4-20 x 1/2" Whiz Flange	37	1031	Key, 3/16sq x 1/2"	54	9345	Throttle Cable
18	8199	Cover	38	1125S	Sprocket, 9T #420	55	8441	Caliper Cover - Right
19	8214-2	Adapter Plate	39	5090	Bearing	* = Not Available Separately		
20	1263	Nut, 5/16-18 Flange	40	2430	Spanner	ASM = Assembly NI = Not Illustrated		