

Operator's Manual SUPPLEMENT

40 Series pulley

MANCO MODEL NO.
808-01

WARNING:
Read Engine
Owner's Manual,
Vehicle Operator's
Manual, and
Supplement
Carefully Before
Operating
Vehicle.

Parts List

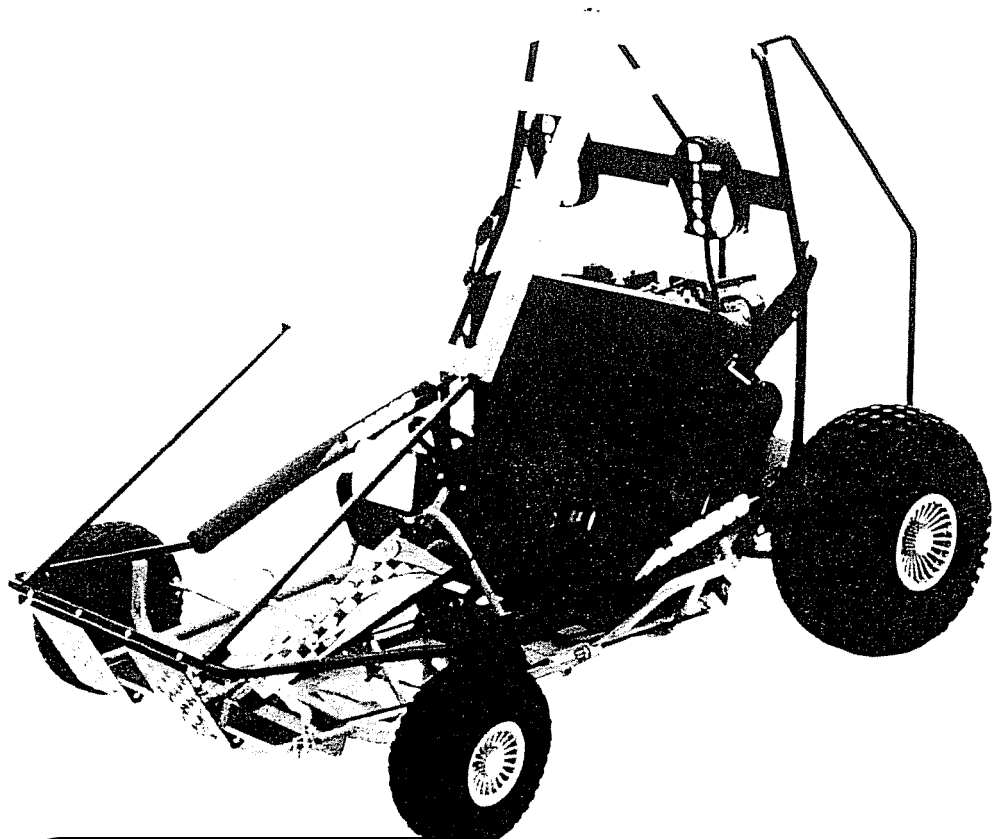

ORDERING PARTS

FAST & EASY!

- 1) Seek Part(s) from your models illustrated diagram, cross over REF# to PART#
- 2) Type PART# into sites [Search Box] at GoKartsRus.com TIP! - RIGHT CLICK LINK, SELECT OPEN IN NEW TAB
- 3) Add all needed parts to Shopping Cart | Complete "Checkout" | ✓ Done!

If a part does not come up in a Site Search, please [Contact Us](#) (include part# in email)

LOWEST PRICES!

BEFORE OPERATING THIS VEHICLE, THE OWNER AND/OR OPERATOR MUST UNDERSTAND THE VEHICLE WAS NOT DESIGNED OR MANUFACTURED TO MEET SPECIFICATIONS FOR USE ON PUBLIC ROADS, STREETS, HIGHWAYS, OR THOROUGHFARES AND HAVE READ AND HAVE AN UNDERSTANDING OF ALL THE INSTRUCTIONS FOR SAFE ASSEMBLY AND OPERATION AS WELL AS THE INSTRUCTIONS GOVERNING THE ENGINE AND OTHER PORTIONS OF THE VEHICLE.

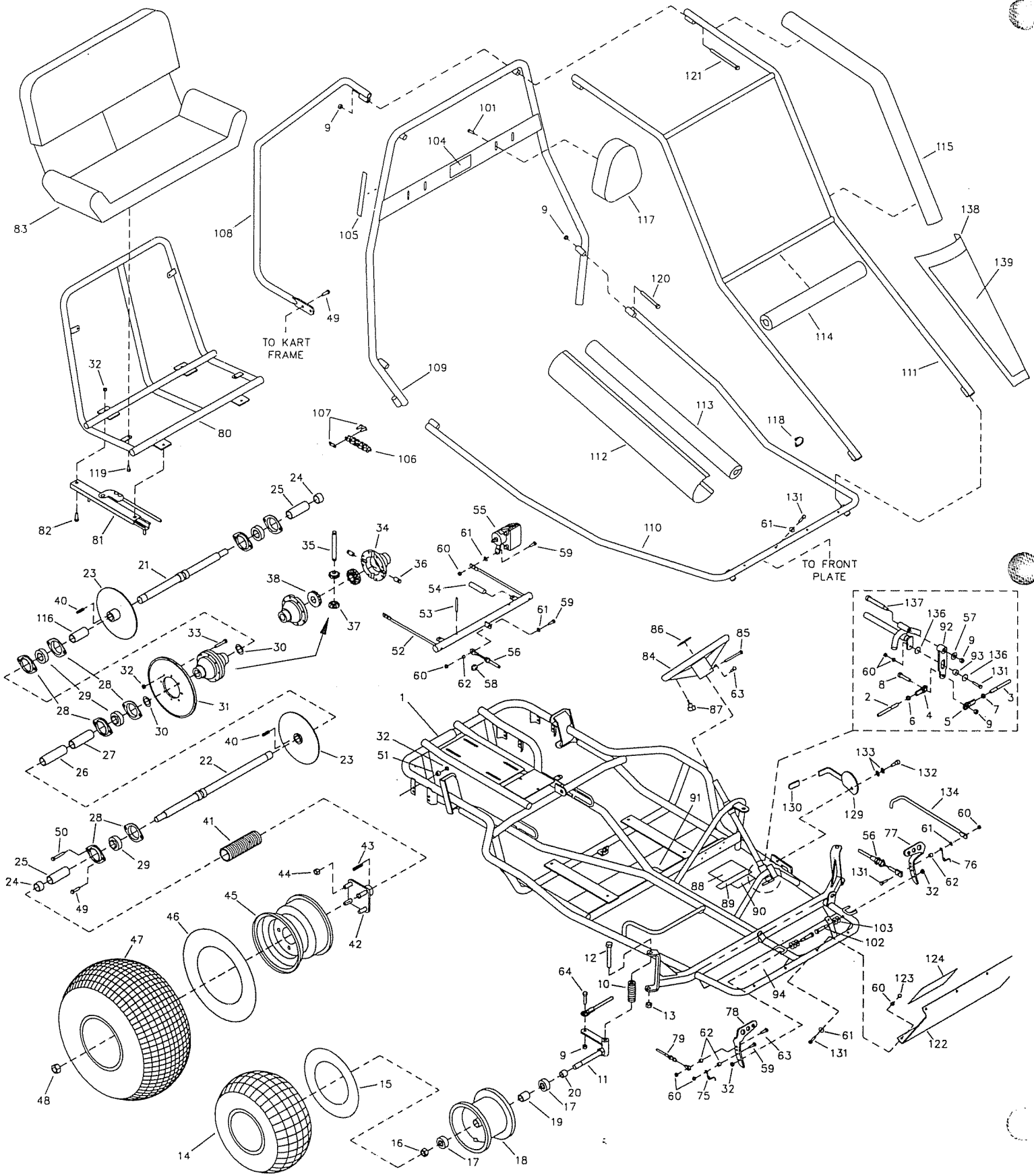

REPAIR PARTS - 808-01

REF.	PART	DESCRIPTION	REF.	PART	DESCRIPTION
NO.	NO.		NO.	NO.	
1	8675-7	Frame - Green	71	---	
2	8341	Tie Rod, 23 inch	72	---	
3	3224	Tie Rod, 8-3/4 inch	73	---	
4	1414	Rod End - RH	74	---	
5	1415	Rod End - LH	75	9503	Spring, Right Wound
6	9092	Nut, 3/8-24 RH Jam	76	9502	Spring, Left Wound
7	9094	Nut, 3/8-24 LH Jam	77	1436	Brake Pedal
8	9145	Bolt, 3/8-16 x 1-3/4"	78	6309	Throttle Pedal, Trimmed
9	9085	Nut, 3/8-16 Toplock	79	8173	Throttle Cable
10	8448	Compression Spring	80	8688-2	Seat Frame Weldment
11	2457	Spindle, Right	81	8655	Seat Slide Pair
NI	2458	Spindle, Left	82	2264	Bolt, 5/16-18 x 3/4"
12	8453	Bolt, 1/2-13 x 6-1/2"	83	8692	Seat Back/Bottom
13	1012	Nut, 1/2-13 Toplock	84	6038	Steering Wheel
14	4915	Tire, 145/70 x 6 Knobby	85	9080	Bolt, 1/4-20 x 2-3/4"
15	3802	Inner Tube, 6"	86	1689	Decal, Steering Wheel
16	1046	Nut, 5/8-11 Toplock	87	6394	Stop Switch Assembly
17	5090	Bearing, 5/8 ID	88	4504	Decal, Yellow Warning
18	9309FP	Wheel Assembly, Front (incl. 14-19)	89	8153	Decal, Age Restriction
19	5950	Spanner, 5/8 ID x 2-1/8"	90	8399	Decal, Seat Belt Warning
20	5157	Spacer, 5/8 ID x 3/4"	91	8676	Grommet
21	8327	Axle Weldment - Short	92	9834-2	Steering Crank Weldment
22	8328	Axle Weldment - Long	93	9873	Cam Follower Bearing
23	6314	Brake Rotor	94	1441	Decal, Front Floor Pan
24	4914	Spacer, 1" ID x 9/16"	95	---	
25	8462	Spacer, 1" ID x 2-3/4"	96	---	
26	4662	Spacer, 1" ID x 4-1/4"	97	---	
27	4659	Spacer, 1" ID x 3-3/4"	98	---	
28	6617	Bearing Flange	99	---	
29	3941	Bearing, 1" ID	100	---	
30	PX2970	#9 Machinery Bushing	101	5839	Bolt, 1/4-20 x 3/4" Flanged Whiz
ASM	8344	Differential/Sprocket Asm. (incl. 31-38)	102	1447	Pedal Bolt
31	6819	Sprocket - 54 Tooth	103	9091	Washer, 3/8 Flat
32	1189	Nut, 5/16-18 Toplock	104	8138	Decal, Warning: Long Hair
33	9186	Bolt, 5/16-18 x 1-1/2 GR5	105	6540	Decal, Warning: Wear Helmet
34		Housing w/ Bearing	106	9343	Chain, 420 x 71 Links plus Master Link
35		Pinion Shaft	107	2037	Master Link, 420 Chain
36		Pinion Shaft Plug	108	9527-2	Rear Bar
37		Pinion Gear	109	8321-2	Center Bar
38		Bevel Gear	110	8322-2	Front Bar
39	---		111	8320-2	Overhead Bar
40	1775	Key, 1/4 sq. x 1-1/4"	112	8599	Arm Pad Cover
41	K810-01	Axle Guard Kit	113	9759B	Foam, 30" Black
42	1557	Wheel Hub w/Studs	114	9762B	Foam, 20" Black
43	6123	Key, 1/4 sq. x 1-3/4"	115	9758B	Foam, 43" Black
44	1428	Nut, 1/2-13 Cone Wheel	116	8463	Spacer, 1" ID x 2.625"
ASM	1412	Wheel Asm, Rear (incl. 45-47)	117	8615	Headrest
45	1451	Wheel Rim, 8"	118	9777	Plastic Hose Clamp, 7/8" ID
46	1430	Inner Tube, 8" (Repair Part Only)	119	1876	Bolt, 1/4-20 x 5/8" Flanged Whiz
47	1452	Tire, 22 x 11 - 8 Tubeless	120	2386	Bolt, 3/8-16 x 3-1/2"
48	9162	Nut, 3/4-10 Toplock	121	6452	Bolt, 3/8-16 x 5"
49	9176	Bolt, 5/16-18 x 1"	122	8704-2	Front Plate
50	6573	Bolt, 5/16-18 x 1-3/4"	123	1443	Nut, 1/4-20 Acorn
51	9674	Spacer, 3/8 ID x 3/8"	124	8419	Decal, Front Plate
52	8331-2	Brake Link Weldment	125	---	
53	9455	Spring Pin	126	---	
54	9780	Extension Spring	127	---	
55	8197	Brake Calliper, Left	128	---	
NI	8444	Brake Calliper, Right	129	8673-2	Parking Brake Handle
56	8640	Brake Cable	130	4900	Brake Handle Cover
57	9022	Washer, 1/2 Flat	131	1849	Bolt, 1/4-20 x 1-1/2"
58	9174	E-Ring	132	9172	Bolt, 3/8 x 1/4 Shoulder
59	1847	Bolt, 1/4-20 x 1"	133	6441	Washer, 3/8 ID Spring
60	9057	Nut, 1/4-20 Toplock	134	8672	Parking Brake Rod
61	1854	Washer, No. 14 Flat	135	6440	Nut, 5/16-18 Jam
62	1389	Bushing, 1/4" ID x 5/16"	136	9872	Washer, 1/4 Flat
63	9160	Bolt, 1/4-20 x 7/8"	137	9871	Shoulder Bolt, 1/2 x 3
64	9146	Bolt, 3/8-16 x 1-1/2"	138	2257	Fairing
65	---		139	8418	Decal, Fairing
66	---		NI	9247R4	Assembly Instructions
67	---		NI	6477	Dingo Operator's Manual
68	---		NI	8220	Tecumseh Engine Manual
69	---				
70	---				

ASM = Assembly

NI = Not Illustrated

CALIPER BREAKDOWN

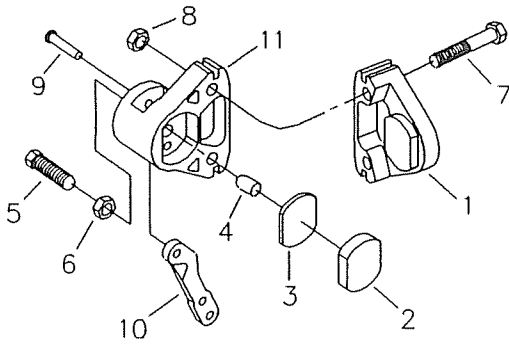

REF. NO	PART NO	DESCRIPTION
ASM	8197	Brake Callper (Incl. 1-11)
ASM	9810	Brake Pad Svc Kit (Incl. 1-3)
1	*	Anvil w/Lining
2	*	Brake Lining
3	3928	Backing Plate
4	3930	Actuator Pin
5	3931	Adjuster Pin
6	3932	Nut, Jam
7	9158	Bolt, 3/8-16 x 2-1/4"
8	9085	Nut, 3/8-16 Toplock
ASM	6534	MB-1 Service Kit (Incl. 9-11)
9	*	Groove Pin
10	*	Lever
11	*	Brake Housing

TORQUE CONVERTER BREAKDOWN

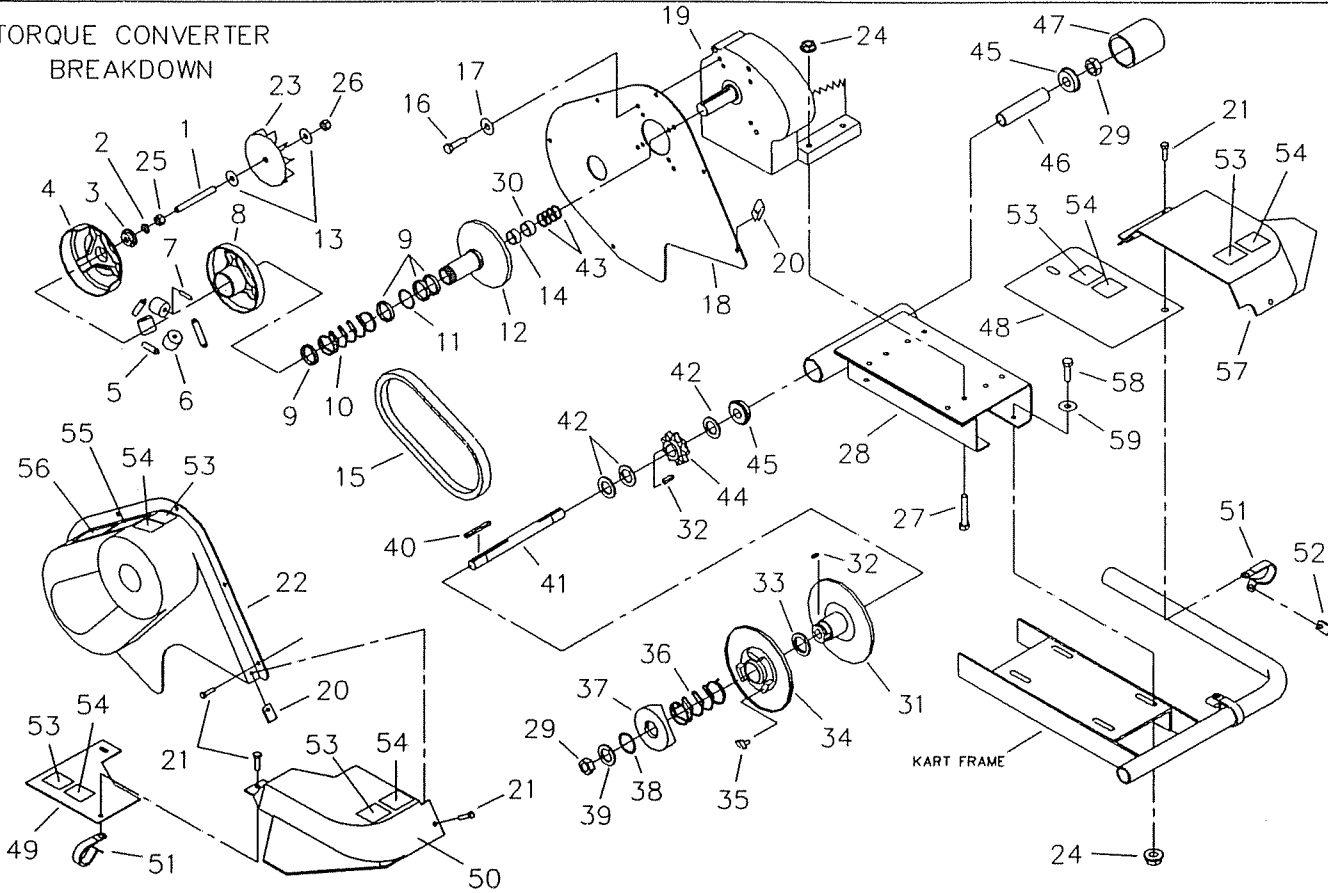

REF. NO	PART NO	DESCRIPTION
1	8689	Stud, 3/8-24 x 4-1/4"
2	1130	Washer, 3/8 Split Lock
3	2468	Washer, Pilot
ASM	2594	Driver Pulley Assembly (Incl. REF. 4-12)
4	*	Cover and Drive Plate
5	2472	Extension Spring
6	2470	Cam Roller
7	2471	Spring Clip
8	*	Moveable Face and Hub
9	2474	Guide Bushing
10	2475	Compression Spring
11	*	Retaining Ring
12	*	Fixed Face and Post
13	9125	Washer, 3/8 Flat
14	1082	Spacer, 1" ID x 7/16
15	6814	Belt, Symmetrical
16	9101	Bolt, 5/16-24 x 3/4"
17	9060	Washer, 5/16 Plain
18	8745	Cover Panel
19	8196	Engine, 8HP Tecumseh
20	2449	Nut, Tinnerman
21	9006	Bolt, 1/4-20 x 1/2" Whiz Flange
22	8739	Cover Assembly

REF. NO	PART NO	DESCRIPTION
23	8600	Impeller
24	1263	Nut, 5/16-18 Flange
25	2388	Nut, 3/8-24 Hex
26	9123	Nut, 3/8-24 Toplock Hex
27	9186	Bolt, 5/16-18 x 1-1/2"
28	8908	Chassis
29	9155	Nut, 5/8-11 Jam
30	4914	Spacer, 1" ID x 9/16
ASM	8664	Driven Pulley Assembly (Incl. REF. 31-39)
31	*	Fixed Face and Post
32	1031	Key, 3/16sq x 1/2"
33	2483	Spacer
34	*	Moveable Face and Cam
35	2516	Button Insert
36	2480	Torsion Spring
37	*	Fixed Cam
38	2478	Thrust Washer
39	2477	Retaining Ring
40	3403	Key, 3/16sq x 2"
41	8854	Jackshaft, 13.69"
42	1119	Spacer, 5/8ID x 1/8"
43	3887	Spacer, 1" ID x 1/16
44	1125S	Sprocket, 9T #420

REF. NO	PART NO	DESCRIPTION
45	5090	Bearing
46	2430	Spanner
47	8194	Cap, Plastic
48	8443	Right Deck Cover
49	8924	Left Deck Cover
50	8923	Caliper Cover - Left
51	8266	Loop Clip
52	8227	Clip Nut
53	1049	Decal, Caution
54	4912	Decal, Warning: Guard
55	8138	Decal, Warning: Entanglement
56	6958	Decal, Tire Pressure
57	8441	Callper Cover - Right
58	9176	Bolt, 5/16-18 x 1"
59	9030	Washer, 5/16 Int. Lock
NI	9677	Decal, Warning: Hot Surfaces
NI	9678	Decal, Warning: Eng. Exhaust
NI	5964	Decal, Oil Warning

* = Not Available Separately
 ASM = Assembly NI = Not Illustrated