

# Operator's Manual SUPPLEMENT

Model No.  
810U-0

## ⚠ WARNING:

Read Engine  
Owner's Manual,  
Vehicle Operator's  
Manual, and  
Supplement  
Carefully Before  
Operating Vehicle.

Parts List



## ORDERING PARTS

FAST & EASY!

- 1) Seek Part(s) from your models illustrated diagram, cross over REF# to PART#
- 2) Type PART# into sites [Search Box] at [GoKartsRus.com](http://GoKartsRus.com) TIP! - RIGHT CLICK LINK, SELECT OPEN IN NEW TAB
- 3) Add all needed parts to Shopping Cart | Complete "Checkout" | ✓ Done!

If a part does not come up in a Site Search, please [Contact Us](#) (include part# in email)

LOWEST PRICES!

# THIS VEHICLE IS FOR OFF-ROAD USE ONLY

BEFORE OPERATING THIS VEHICLE, THE OWNER AND/OR OPERATOR MUST UNDERSTAND THE VEHICLE WAS NOT DESIGNED OR MANUFACTURED TO MEET SPECIFICATIONS FOR USE ON STREETS, HIGHWAYS, OR THOROUGHFARES AND HAVE READ AND HAVE AN UNDERSTANDING OF ALL THE INSTRUCTIONS FOR SAFE ASSEMBLY AND OPERATION AS WELL AS THE INSTRUCTIONS GOVERNING THE ENGINE AND OTHER PORTIONS OF THE VEHICLE.

## REPAIR PARTS - 810U-0

REF. NO.	PART NO.	DESCRIPTION	REF. NO.	PART NO.	DESCRIPTION
1	8675-7	Frame - Green	71	---	
2	8341	Tie Rod, 23 inch	72	---	
3	3224	Tie Rod, 8-3/4 inch	73	---	
4	1414	Rod End - RH	74	---	
5	1415	Rod End - LH	75	9503	Spring, Right Wound
6	9092	Nut, 3/8-24 RH Jam	76	9502	Spring, Left Wound
7	9024	Nut, 3/8-24 LH Jam	77	1436-16	Brake Pedal
8	9145	Bolt, 3/8-16 x 1-3/4"	78	6309-16	Throttle Pedal, Trimmed
9	9085	Nut, 3/8-16 Toplock	79	8173	Throttle Cable
10	8448	Compression Spring	80	8688-2	Seat Frame Weldment
11	2457-2Z	Spindle, Right	81	8655	Seat Slide Pair
NI	2458-2Z	Spindle, Left	82	2264	Bolt, 5/16-18 x 3/4"
12	8453	Bolt, 1/2-13 x 6-1/2"	83	8692	Seat Back/Bottom
13	1012	Nut, 1/2-13 Toplock	84	6038	Steering Wheel
14	9309FP	Wheel Assembly, Front (incl. 15-18)	85	9080	Bolt, 1/4-20 x 2-3/4"
15	4915	Tire, 145/70 x 6 Knobby	86	---	
16	3802	Inner Tube, 6" (Repair Part Only)	87	11072	Stop Switch /Headlight Harness Asm
17	5090	Bearing, 5/8 ID	88	11330	Decal Sheet, Frame & Engine Warnings
18	5950	Spanner, 5/8 ID x 2-1/8"	89	---	
19	1046	Nut, 5/8-11 Toplock	90	---	
20	5157-16	Spacer, 5/8 ID x 3/4"	91	8676	Grommet
21	10455	Axle Weldment	92	9834-2	Steering Crank Weldment
22	---		93	9873	Cam Follower Bearing
23	6314H	Brake Rotor	94	1441	Decal, Front Floor Pan Scuff
24	4914-16	Spacer, 1" ID x 9/16"	95	8373	Seat Belt Shoulder / Lap
25	8462-16	Spacer, 1" ID x 2-3/4"	96	9188	Bolt, 1/2-13 x 1-1/2"
26	6780-16	Spacer, 1" ID x 3-7/8"	97	---	
27	6783-16	Spacer, 1" ID x 4-1/8"	98	---	
28	4913-16	Spacer, 1" ID x 3"	99	---	
29	6617	Bearing Flange	100	---	
30	3941H	Bearing, 7/8" Hex	101	5839	Bolt, 1/4-20 x 3/4" Flanged Whiz
31	9060	Washer, 5/16 Flat	102	1447	Pedal Bolt
32	1189	Nut, 5/16-18 Toplock	103	9091	Washer, 3/8 Flat
33	9186	Bolt, 5/16-18 x 1-1/2 GR5	104	11329	Decal Sheet, Center Bar Warnings
ASM	6420H	Sprocket Asm (incl. 34-37)	105	---	
34	6282	Sprocket 420P 54T	106	9343	Chain, 420 x 71 Links plus Master Link
35	6280H	Sprocket Hub	107	2037	Master Link, 420 Chain
36	9006	Bolt, 1/4-20 x 1/2" Whiz Flange	108	8702-7	Rear Bar
37	6701	Bolt, 5/16-18 x 1-1/4" SHCS	109	8700-7	Center Bar
38	---		110	8699-7	Front Bar
39	11347	Headlight Asm	111	8701-7	Overhead Bar
40	---		112	11267	Arm Pad Cover
41	K808-02	Axle Guard Kit	113	---	
42	1557H	Wheel Hub w/Studs	114	---	
43	---		115	---	
44	1428	Nut, 1/2-13 Cone Wheel	116	---	
ASM	1412	Wheel Asm, Rear (incl. 45-47)	117	6320	Headrest
45	1451	Wheel Rim, 8"	118	8730	Plastic Hose Clamp, 1-1/4" ID
46	1430	Inner Tube, 8" (Repair Part Only)	119	1876	Bolt, 1/4-20 x 5/8" Flanged Whiz
47	1452	Tire, 22 x 11 - 8 Tubeless	120	2386	Bolt, 3/8-16 x 3-1/2"
48	9162	Nut, 3/4-10 Toplock	121	6452	Bolt, 3/8-16 x 5"
49	9176	Bolt, 5/16-18 x 1"	122	10490-7	Front Plate
50	6573	Bolt, 5/16-18 x 1-3/4"	123	---	
51	9674-16	Spacer, 3/8 ID x 3/8"	124	---	
52	8331-2	Brake Link Weldment	125	---	
53	9455	Spring Pin	126	---	
54	9780	Extension Spring	127	---	
55	8197	Brake Caliper, Left	128	---	
NI	8444	Brake Caliper, Right	129	8673-2	Parking Brake Handle
56	8640	Brake Cable	130	4900	Brake Handle Cover
57	9022	Washer, 1/2 Flat	131	1849	Bolt, 1/4-20 x 1-1/2"
58	9174	E-Ring	132	9172	Bolt, 3/8 x 1/4 Shoulder
59	1847	Bolt, 1/4-20 x 1"	133	6441	Washer, 3/8 ID Spring
60	9057	Nut, 1/4-20 Toplock	134	8672	Parking Brake Rod
61	1854	Washer, No. 14 Flat	135	6440	Nut, 5/16-18 Jam
62	1389	Bushing, 1/4" ID x 5/16	136	9872	Washer, 1/4 Flat
63	9160	Bolt, 1/4-20 x 7/8"	137	9871	Shoulder Bolt, 1/2 x 3
64	9146	Bolt, 3/8-16 x 1-1/2"	138	2257	Fairing
65	---		NI	6477	Dingo Operator's Manual
66	---		NI	8220	Tecumseh Engine Manual
67	---				
68	---				
69	---				
70	---				

ASM = Assembly

NI = Not Illustrated



### CALIPER BREAKDOWN

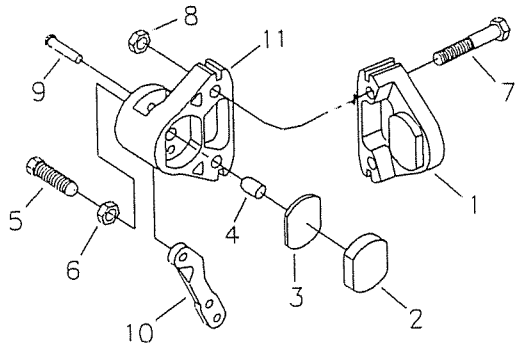

REF. NO	PART NO	DESCRIPTION
ASM	8197	Brake Caliper (incl. 1-11)
ASM	9810	Brake Pad Svc Kit (incl. 1-3)
1	*	Anvil w/Lining
2	*	Brake Lining
3	3928	Backing Plate
4	3930	Actuator Pin
5	3931	Adjuster Pin
6	3932	Nut, Jam
7	9158	Bolt, 3/8-16 x 2-1/4"
8	9085	Nut, 3/8-16 Toplock
ASM	6534	MB-1 Service Kit (incl. 9-11)
9	*	Groove Pin
10	*	Lever
11	*	Brake Housing

### TORQUE CONVERTER BREAKDOWN

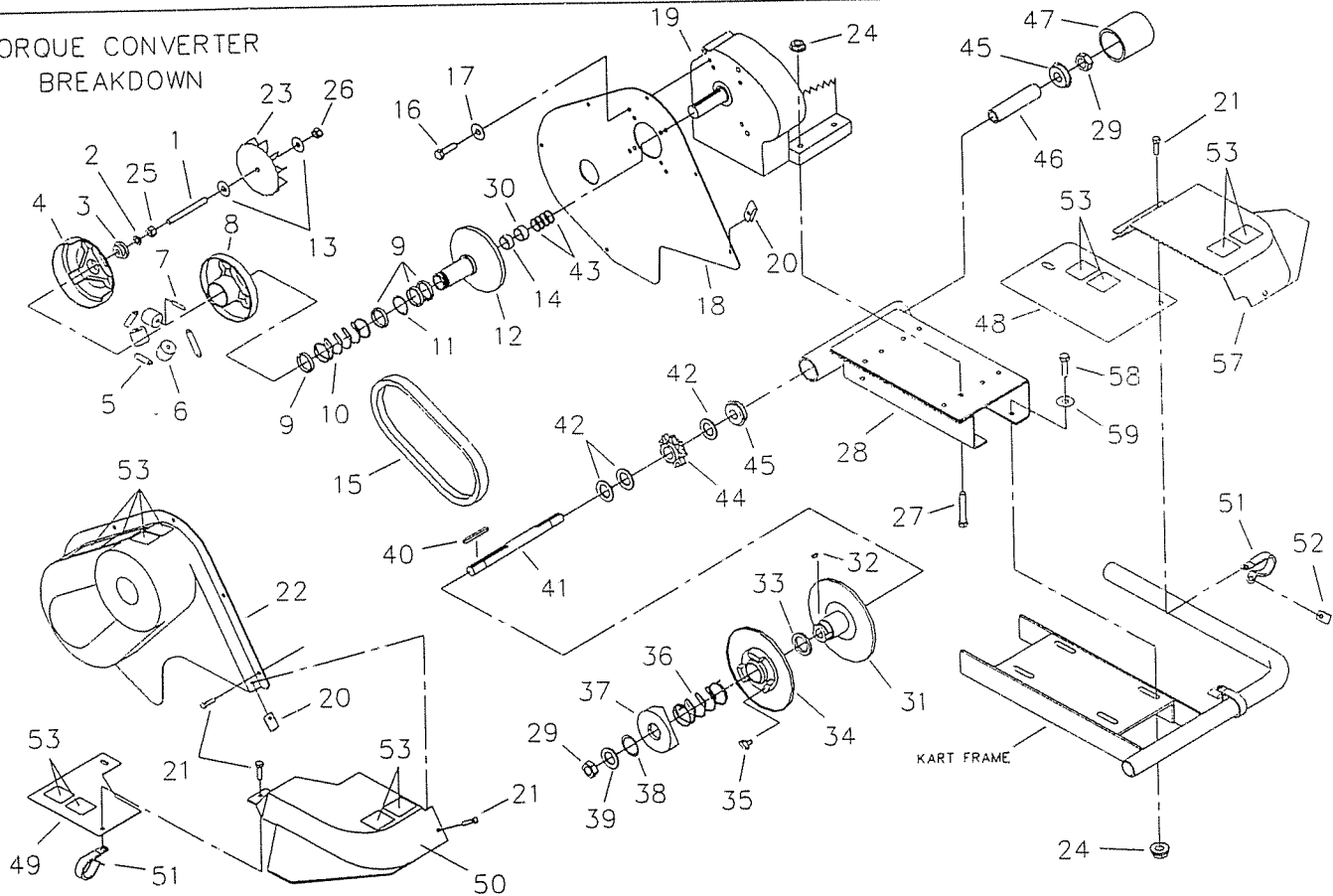

REF. NO	PART NO	DESCRIPTION	REF. NO	PART NO	DESCRIPTION	REF. NO	PART NO	DESCRIPTION
1	8689	Stud, 3/8-24 x 4-1/4"	23	8600	Impeller	45	5090	Bearing
2	1130	Washer, 3/8 Split Lock	24	1263	Nut, 5/16-18 Flange	46	2430	Spanner
3	2468	Washer, Pilot	25	2388	Nut, 3/8-24 Hex	47	8194	Cap, Plastic
ASM	2594	Driver Pulley Assembly (incl. REF. 4-12)	26	9123	Nut, 3/8-24 Toplock Hex	48	8443	Right Deck Cover
4	*	Cover and Drive Plate	27	9186	Bolt, 5/16-18 x 1-1/2"	49	8924	Left Deck Cover
5	2472	Extension Spring	28	8908-2	Chassis	50	8923	Caliper Cover - Left
6	2470	Cam Roller	29	1466	Nut, 5/8-11 Flexlok Jam	51	8266	Loop Clip
7	2471	Spring Clip	30	4914-16	Spacer, 1" ID x 9/16	52	8227	Clip Nut
8	*	Moveable Face and Hub	ASM	8664	Driven Pulley Assembly (incl. REF. 31-39)	53	11329	Decal Sheet, Frame & Engine Warnings
9	2474	Guide Bushing	31	*	Fixed Face and Post	54	---	
10	2475	Compression Spring	32	---		55	---	
11	*	Retaining Ring	33	2483	Spacer	56	---	
12	*	Fixed Face and Post	34	*	Moveable Face and Cam	57	8441	Caliper Cover - Right
13	9125	Washer, 3/8 Flat	35	2516	Button Insert	58	9176	Bolt, 5/16-18 x 1"
14	1082	Spacer, 1" ID x 7/16	36	2480	Torsion Spring	59	9030	Washer, 5/16 Int. Lock
15	6814	Belt, Symmetrical	37	*	Fixed Cam			
16	9101	Bolt, 5/16-24 x 3/4"	38	2478	Thrust Washer			
17	9060	Washer, 5/16 Plain	39	2477	Retaining Ring			
18	8745	Cover Panel	40	3403	Key, 3/16sq x 2"			
19	10410	Engine, 10HP Tecumseh	41	8854	Jackshaft, 13.69"			
20	2449	Nut, Tinnerman	42	1119	Spacer, 5/8ID x 1/8"			
21	9006	Bolt, 1/4-20 x 1/2" Whiz	43	3887	Spacer, 1" ID x 1/16			
22	8739	Cover Assembly	44	8720	Sprocket, 9T #420			

\* = Not Available Separately  
 ASM = Assembly    NI = Not Illustrated