

## ORDERING PARTS

**FAST & EASY!**

- 1) Seek Part(s) from your models illustrated diagram, cross over REF# to PART#
- 2) Type PART# into sites [Search Box] at [GoKartsRus.com](http://GoKartsRus.com) TIP! - RIGHT CLICK LINK, SELECT OPEN IN NEW TAB
- 3) Add all needed parts to Shopping Cart | Complete "Checkout" | ✓ Done!

*If a part does not come up in a Site Search, please [Contact Us](#) (include part# in email)*

**LOWEST PRICE!**



## 200 SERIES 150cc LUTV OWNER'S MANUAL

15731 Rev. A  
pub. 06/17/2015

**ILLUSTRATED PARTS LISTS ARE AVAILABLE ONLINE AT [AMSPORTWORKS.COM](http://AMSPORTWORKS.COM) OR BY CALLING 800-643-7332**

***THIS VEHICLE IS FOR OFF-ROAD USE ONLY. THIS VEHICLE IS NOT DESIGNED FOR USE ON RENTAL TRACKS OR RACING***

BEFORE OPERATING THIS VEHICLE, THE OWNER AND EACH OPERATOR MUST UNDERSTAND THIS VEHICLE WAS NOT DESIGNED OR MANUFACTURED TO MEET SPECIFICATIONS FOR USE ON PUBLIC ROADS, STREETS, HIGHWAYS AND THOROUGHFARES. THE OWNER AND EACH OPERATOR MUST READ AND UNDERSTAND ALL THE INSTRUCTIONS FOR PROPER ASSEMBLY AND SAFE OPERATION, AS WELL AS THE INSTRUCTIONS CONCERNING THE ENGINE AND ALL OTHER PORTIONS OF THE VEHICLE. CHILDREN MUST BE 16+ YEARS OF AGE FOR THIS VEHICLE AND SUPERVISED BY AN ADULT AT ALL TIMES WHEN USING THIS VEHICLE. SPEED REDUCTION KITS ARE AVAILABLE FOR ALL VEHICLES. THIS VEHICLE IS NOT A TOY.

# ASW, LLC /dba American Sportworks Limited Warranty on Emission Control System

## Your warranty rights and obligations

The U.S. Environmental Protection Agency and ASW, LLC /dba American Sportworks (hereinafter "AMERICAN SPORTWORKS") are pleased to explain the emission control system warranty on your Off-Road Vehicle. New off-road vehicles must be designed, built and equipped to meet U.S. EPA standards. AMERICAN SPORTWORKS must warrant the emission control system on your vehicle for 5,000 km, or at least 30 months, whichever comes first, provided that there has been no abuse, neglect or improper maintenance of your vehicle. This off-road vehicle was designed to meet the emission standards for 10,000 km, or five years, whichever comes first.

Your emission control system may include parts such as the carburetor or fuel injection system, the ignition system, catalytic converter and engine computer, if it is equipped. Also included may be hoses, belts, connectors and other emission-related assemblies.

Where a warrantable condition exists, AMERICAN SPORTWORKS will repair your vehicle at no cost to you, including diagnosis, parts and labor.

If an emission-related part on your vehicle is defective, the part will be repaired or replaced by AMERICAN SPORTWORKS. This is your emission control system DEFECTS WARRANTY.

**NOTICE!** Use of any AMERICAN SPORTWORKS vehicle in any type of competitive event completely and absolutely voids this and all other warranties offered by AMERICAN SPORTWORKS.

## Owner's warranty responsibilities

As the vehicle owner, you are responsible for the performance of the required maintenance listed in your owner's manual. AMERICAN SPORTWORKS recommend that you retain all receipts covering maintenance on your vehicle, but AMERICAN SPORTWORKS cannot deny warranty solely for the lack of receipts or for your failure to ensure the performance of all scheduled maintenance.

You are responsible for presenting your vehicle to the AMERICAN SPORTWORKS dealer as soon as a problem exists. The warranty repairs should be completed in a reasonable amount of time, not to exceed 30 days.

As the vehicle owner, you should be aware that AMERICAN SPORTWORKS may deny your warranty coverage if your vehicle or a part has failed due to abuse, neglect, improper maintenance or unapproved modifications.

If you use your vehicle in any type of competitive event, this warranty is immediately and completely void.

If you have any questions regarding your warranty rights and responsibilities, you should contact ASW, LLC /dba American Sportworks, 7625 Disalle Blvd, Fort Wayne, IN 46825 (800-643-7332) or the U.S. Environmental Protection Agency, 2000 Traverwood Drive, Ann Arbor, MI 48105.

## AMERICAN SPORTWORKS warrants that each new off-road vehicle:

**A.** is designed, built and equipped so as to conform at the time of initial retail purchase with all applicable regulations of the United States Environmental Protection Agency, and;

**B.** is free from defects in material and workmanship which cause such vehicle to fail to conform to applicable regulations of the United States Environmental Protection Agency for the periods specified above.

**I. COVERAGE.** Warranty defects shall be remedied during customary business hours at any authorized AMERICAN SPORTWORKS dealer located within the United States of America in compliance with the Clean Air Act and applicable regulations of the United States Environmental Protection Agency. Any part or parts replaced under this warranty shall become the property of AMERICAN SPORTWORKS.

**II. LIMITATIONS.** This Emission Control System Warranty shall not cover any of the following:

**A:** Repair or replacement as a result of

- (1) accident,
- (2) misuse,
- (3) repairs improperly performed or replacements improperly installed,
- (4) use of replacement parts or accessories not conforming to specifications set forth by AMERICAN SPORTWORKS, which adversely affect performance and/or
- (5) use in competitive racing or related events.

**B:** Inspections, replacement of parts and other services and adjustments required for required maintenance.

**C:** Any vehicle equipped with an odometer or hour meter on which the odometer mileage or hour meter reading has been changed so that actual mileage cannot be readily determined.

### III. LIMITED LIABILITY

**A.** The liability of AMERICAN SPORTWORKS under this Emission Control System Warranty is limited solely to the remedying of defects in material or workmanship by an authorized AMERICAN SPORTWORKS dealer at its place of business during customary business hours. This warranty does not cover inconvenience or loss of use of the vehicle or transportation of the vehicle to or from the AMERICAN SPORTWORKS dealer. AMERICAN SPORTWORKS shall not be liable for any other expenses, loss or damage, whether direct, incidental, consequential or exemplary arising in connection with the sale or use of or inability to use the AMERICAN SPORTWORKS vehicle for any purpose. Some states do not allow the exclusion or limitation of any incidental or consequential damages, so the above limitations may not apply to you.

**B.** No express emission control system warranty is given by AMERICAN SPORTWORKS, except as specifically set forth herein. Any emission control system warranty implied by law, including any warranty of merchantability or fitness for a particular purpose, is limited to the express emission control system warranty terms stated in this warranty. The foregoing statements of warranty are exclusive and in lieu of all other remedies. Some states do not allow limitations on how long an implied warranty lasts, so the above limitations may not apply to you.

**C.** No dealer is authorized to modify this Limited Emission Control System Warranty issued by AMERICAN SPORTWORKS.

**IV. LEGAL RIGHTS.** This warranty gives you specific legal rights, and you may also have other rights which vary from state to state.

**V.** This warranty is in addition to the AMERICAN SPORTWORKS limited vehicle warranty.

**VI. ADDITIONAL INFORMATION.** Any replacement part that is equivalent in performance and durability may be used in the performance of any maintenance or repairs. However, AMERICAN SPORTWORKS is not liable for these parts. The owner is responsible for the performance of all required maintenance. Such maintenance may be performed at a service establishment or by any individual. The warranty period begins on the date the off-road vehicle is delivered to an ultimate purchaser.



## limited warranty

### Utility Vehicle / Light Utility Vehicle

**Limited Warranty:** American SportWorks (hereinafter referred to as “ASW”), hereby warrants to the original purchaser, that your new ASW UTV/LUTV will be free from defects in material and workmanship for a period of one (1) year from date of purchase, except as provided below. Certain engines may carry an engine manufacturer’s warranty which is longer than one (1) year. These engines are not covered by this ASW warranty. Please refer to the engine manufacturer’s warranty policy included with your ASW product for its warranty repair requirements and procedures.

**ASW Warranty Responsibilities:** ASW, if notified of a defect in material or workmanship during the period of warranty, will repair or replace, at its option, defective parts covered by this warranty at no charge, other than the reasonable cost for the transportation of the component(s). ASW will also agree to pay reasonable charges for labor, if necessary, to perform a warranty repair.

**Warranty Claim Requirements and Procedures:** In order to be able to claim under this warranty the original purchaser must maintain and operate the vehicle in accordance with the instructions provided in the Operator’s Manual, engine manual, the supplements thereto, and labels affixed to the vehicle. Additionally, within (10) days of the discovery of an alleged defect, the original purchaser must contact ASW’s Customer Service Department at 1-800-643-7332, 7625 DiSalle Boulevard, Fort Wayne, IN 46825 or via the internet at [www.amsportworks.com](http://www.amsportworks.com). The repair or replacement of any part or parts under this Limited Warranty shall not extend the term of the warranty beyond the original term as set forth above.

**General Exclusions:** This limited warranty does not cover component failure or damage caused by any of the following: abnormal strain or stress, neglect; abuse; improper assembly of components which were supplied in the factory sealed carton after the vehicle left ASW; improper maintenance, modifications, damage caused by use of non ASW accessories, improper use of the vehicle, including, but not limited to racing, jumping, stunt driving, or any other uses prohibited by the Operator’s Manual. Additionally, this warranty does not cover vehicles which are leased, rented, or used at a concession track.

**Specific Exclusions:** This limited warranty does not apply to components which are subject to normal wear and tear. These items include, but are not limited to, the tires, battery, brakes, throttle, shift and brake cables, drive belt, the torque converter system, chain, seat, lights, fasteners, decals, or body panels and natural cosmetic discoloration of material due to ultraviolet light. Downtime, pick-up and delivery charges are not covered by this warranty. This warranty does not apply to select engines which are covered by a separate manufacturer’s warranty.

**NO IMPLIED WARRANTY OF FITNESS OR MERCHANTABILITY:** THERE ARE NO WARRANTIES WHICH EXTEND BEYOND THE DESCRIPTION ON THE FACE HEREOF. SPECIFICALLY, ASW MAKES NO OTHER WARRANTY OF ANY KIND, EXPRESSED OR IMPLIED. ALL WARRANTIES OF MERCHANTABILITY AND FITNESS FOR A PARTICULAR PURPOSE WHICH EXCEED THE OBLIGATIONS AND TIME LIMITATIONS SPECIFIED IN THE WARRANTY ABOVE ARE HEREBY DISCLAIMED BY ASW AND EXCLUDED FROM THIS WARRANTY. ADDITIONALLY, THIS WARRANTY EXCLUDES ANY INCIDENTAL OR CONSEQUENTIAL DAMAGES, INCLUDING BUT NOT LIMITED TO LOSS OF USE. SOME STATES DO NOT ALLOW A MANUFACTURER TO EXCLUDE OR LIMIT INCIDENTAL OR CONSEQUENTIAL DAMAGES AND, THEREFORE, THE ABOVE EXCLUSION MAY NOT APPLY TO YOU.

SOME STATES DO NOT ALLOW LIMITATIONS ON HOW LONG AN IMPLIED WARRANTY WILL LAST. IT IS POSSIBLE THAT THE ABOVE LIMITATION MAY NOT APPLY TO YOU. THIS WARRANTY GIVES YOU SPECIFIC LEGAL RIGHTS, AND YOU MAY ALSO HAVE OTHER LEGAL RIGHTS, WHICH VARY, FROM STATE TO STATE.

**Warranty Service:** To obtain warranty service you must return your ASW product to the local authorized dealer or service center, inform them of your warranty problem and provide proof of purchase before any warranty service can be provided. The authorized dealer or service center will inspect the product to determine what repairs or parts are needed and whether they are covered under this warranty. To locate the authorized dealer or service center nearest you please call ASW customer service at 800-643-7332, or visit our website at [www.amsportworks.com](http://www.amsportworks.com) for more information.

**EPA Requirements:** This product complies with all applicable EPA Emissions and, Evaporative requirements. Included with your product’s documents are copies of ASW’s “Emission Control System Warranty Statement”. If your vehicle has a fuel tank mounted remotely from the engine, you will be provided with an “Evaporative Emissions Warranty Statement.”

# TABLE OF CONTENTS

Emissions Warranty . . . . .	i
ASW Limited Warranty . . . . .	ii
<b>SECTION 1 INTRODUCTION</b>	
Forward . . . . .	1
New Vehicle Limited Warranty . . . . .	1
Emissions Warranty . . . . .	1
Cell Phone Use . . . . .	1
<b>SECTION 2 SAFETY</b>	
Use of Warnings and Cautions . . . . .	1
Important Safety Information . . . . .	2
Before You Drive . . . . .	3
While Operating This Vehicle . . . . .	4
Safety Labels . . . . .	5-6
Responsible Operation and Rider Safety . . . . .	7-10
Is Your Vehicle Ready To Drive . . . . .	10-11
<b>SECTION 3 OPERATION</b>	
Operation Controls . . . . .	12-14
Fueling Your Vehicle . . . . .	15
Vehicle Features and Locations . . . . .	15-16
<b>SECTION 4 SERVICE</b>	
Air Cleaner . . . . .	17
Engine Lubrication / Spark Plug / Carburetor Adjustment . . . . .	17-18
Cleaning Instructions / General Lubrication / Chain Lubrication and Adjustment / Front and Rear Shock Adjustment . . . . .	19
Shifter Adjustment / Storage instructions . . . . .	20
<b>SECTION 5 MAINTENANCE</b>	
Wheel Replacement and Alignment / Fuse Replacement / Intake Cleaning - Engine Cooling Fan . . . . .	21
Optional Speed Reduction Installation . . . . .	22
Periodic Checks and Services . . . . .	22
Cable Lubrication . . . . .	22
Specifications and Wiring Diagram . . . . .	23
<b>AVAILABLE PARTS AND ACCESSORIES</b> . . . . .	24
<b>NOTES</b> . . . . .	25
<b>PRE-RIDE INSPECTION CHECKLIST</b> . . . . .	Back Cover

The VIN number begins and ends with a star. **THIS CHARACTER IS NOT IMPORTANT**

## YOUR VEHICLE IDENTIFICATION NUMBER (VIN)

the VIN plate is located on a bar behind the drivers seat

**Making sure your VIN is noted correctly greatly reduces any delays in getting help with parts, accessories or any warranty work.**



Model Number is found on the bar code SKU label near the floor of the unit.

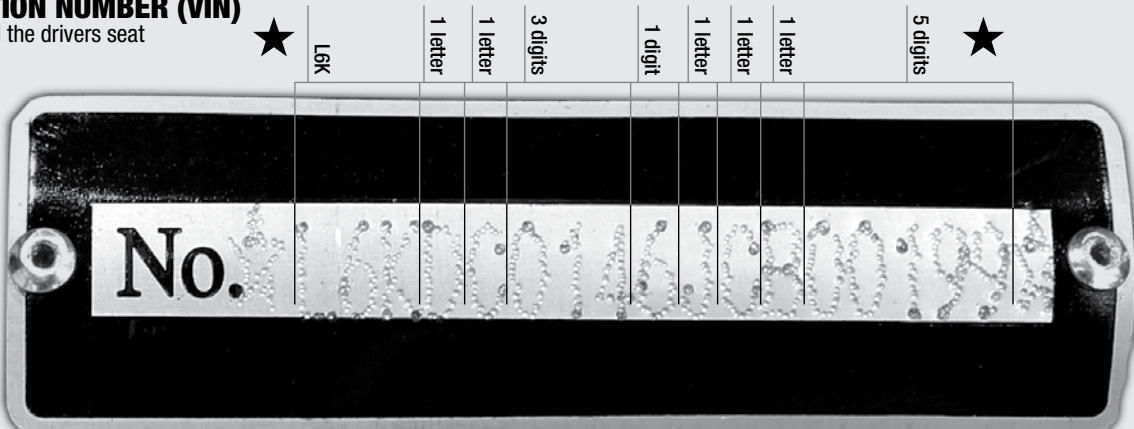

MODEL:

17 DIGIT VIN:

letter / digit / letter letter letter digits digit letter letter letter digits

## FORWARD

Congratulations on the purchase of your American SportWorks / ASW Light Utility Vehicle. Please take a few moments to get well acquainted with your vehicle by reading this Owners' Manual. Before operating this vehicle, the owner, and each operator, must understand that this vehicle was not designed or manufactured to meet specifications for use on public roads, streets, highways and thoroughfares. The owner, operator(s) and passenger(s) must read and understand all the instructions for proper assembly and safe operation, as well as the instructions concerning the engine and all other portions of the vehicle as described and illustrated in this manual and on the included Safety DVD. This unit is not designed for children. This vehicle is not a toy.

Be sure to follow the recommended maintenance schedule and service your vehicle accordingly. Preventative maintenance is extremely important to the safe operation and longevity of your vehicle. **NOTE: A new vehicle requires an engine break in period of 5 hours, whereby the engine oil MUST be changed (See SERVICE section).**

Inexperienced and first time drivers are urged to seek instruction from a dealer or qualified instructor before and during the initial use of this vehicle. It is also recommended to practice in a large open area to become familiar with the operation of the machine.

For more information on American Sportworks and its products visit our website at [www.amsportworks.com](http://www.amsportworks.com).

### New Vehicle Limited Warranty

For a detailed description of warranty coverage for your vehicle, refer to the Warranty section found at the beginning of this Owners' Manual or go to [www.amsportworks.com](http://www.amsportworks.com).

### Emissions Warranty

For a detailed description of the emissions warranty for your vehicle, refer to the Emissions Warranty section found at the beginning of this Owners' Manual or go to [www.amsportworks.com](http://www.amsportworks.com).

### Cell Phone Use

The use of Mobile Communications Equipment has become increasingly important and prevalent in both personal and business affairs. Drivers must not compromise their own, or others safety when using such equipment. ASW recommends against the use of any handheld device while driving this vehicle.

We hope you will have a fun, safe experience with our products and thank you again for choosing an American SportWorks Light Utility Vehicle.

## Visit [Amsportworks.com](http://Amsportworks.com)

for the latest manual revisions, technical service bulletins and illustrated parts lists.

Your vehicle has been supplied with:

***OPERATOR SAFETY MANUAL / OWNERS MANUAL***

The illustrated parts list for you vehicle can be found online at our website at:

***[www.amsportworks.com](http://www.amsportworks.com)***

or by calling American SportWorks at:

***800-643-7332***

# SAFETY SECTION

## SOME WORDS ABOUT SAFETY

Please thoroughly read and understand the Safety Section outlined in this Owners' Manual. The Owners' Manual can also be viewed online at [www.amsportworks.com](http://www.amsportworks.com).

## WARNINGS AND CAUTIONS

 This is the safety alert symbol. When you see this symbol on your machine or in this manual, be alert to the potential for personal injury.

Read and follow all instructions in this Owners' Manual, and any accompanying manuals before attempting to operate this vehicle.

### **WARNING**

***Indicates a potential hazard that could result in severe personal injury or death***

### **CAUTION**

***Indicates a potential hazard which may result in personal injury or damage to the machine.***

***NOTE: Use of the word "NOTE" will alert you to key information or instructions.***

**WARNING****IMPORTANT SAFETY INFORMATION****1. Exhaust fumes are toxic.**

- a. California Proposition 65 WARNING: Gasoline engine exhaust from this machine contains chemicals known to the State of California to cause cancer, birth defects, or other reproductive harm. The engine exhaust contains carbon monoxide, which is a tasteless, odorless, poisonous gas.
- b. NEVER operate this machine indoors or in an enclosed area without adequate ventilation.

**2. Assembly, maintenance, and/or repair of this vehicle should only be performed by designated dealers or authorized small engine centers (for engine repairs) so that no unsafe conditions or modifications are made.****3. This vehicle may have been supplied to you completely assembled. To prevent injury or death read and follow the assembly instructions to make sure the machine was assembled properly.****4. NEVER adjust, repair, or clean the vehicle while it is in motion or with the engine running.****5. All screws, nuts, and bolts must be properly tightened to make sure the vehicle is in safe operating condition.****6. Prevailing-torque type locknuts must be replaced with new after the old locknuts have been removed.**

- a. Replace with the same type of locknut to make sure they function properly. Refer to the Owners Manual / Parts Guide maintenance section for more information on locknuts.

**7. Vehicle modification or removal of original equipment or safety decals can render the machine unsafe for operation.****8. Safety decals must be replaced if they become unreadable or detached from the vehicle.**

- a. If decals are unreadable or missing, warning of potential hazards or safety requirements may be lacking.

**9. Keep guards in place at all times.**

- a. Prevent accidental contact by the operator or service personnel while the machine is running.
- b. The guards over the brake, clutch or torque converter, axle and drive sprockets also help prevent mud and debris from coming in contact with those items.

**10. NEVER tamper with, alter, or change the vehicle's engine governor settings.**

- a. The governor, as set by the engine manufacturer, limits maximum engine speed and protects the engine from damage.
- b. Excessive engine speed is potentially dangerous to operator, passengers, bystanders, and engine.

**11. This vehicle is not designed for use on rental tracks of any kind.****12. The safe operation of this vehicle is dependent upon the operator's ability to exercise proper judgment.**

- a. Operator and passenger must not be too small or too large for controlled operation.
- b. Operator and passenger must be of sufficient age, understanding, mental capacity, and physical capacity to safely operate and ride in the vehicle.
- c. Vehicle should only be operated after mature, supervised instruction and sufficient practice in an un-congested area.

**13. Operator and any passengers MUST wear a properly fitting motorcycle helmet approved by agencies such as the Department of Transportation (DOT), Safety Helmet Council of America (SHCA), or Snell Memorial Foundation (SNELL).**

- a. Most accident fatalities are due to head injuries.
- b. Operator (and any passenger) should also wear face shields or goggles, boots, gloves and other appropriate protective clothing.

**14. Make any repairs or adjustments to the vehicle only when the engine is off and the vehicle is stopped. The spark plug wire MUST be disconnected and kept away from the spark plug to prevent accidental starting.**

- a. When working on, around, or restarting the engine, use extreme caution to avoid contact with the muffler, cylinder head or any potentially hot area on or around the engine.
- b. Ensure that all guards are in place prior to starting the engine.

**15. Washing or operating the vehicle in freezing temperatures can result in water freezing in the throttle cable conduit and/or on the throttle mechanism.**

- a. This may result in the throttle sticking which can cause the engine to continue to run and result in loss of control.

**16. Brush Bars assembled to this vehicle are for decorative purposes and limited brush protection.**

- a. Brush Bars were not designed for rollover or to restrict all brush or tree branches from protruding into operator / passenger compartment.

**17. Read and keep all supplied printed material.**

- a. Supplements to this Operator/Safety Manual contain additional information relative to your specific vehicle model. It is important to keep all of these documents for reference.

**! WARNING****BEFORE YOU DRIVE!****18. Check tire pressure before each use.**

- a. Prior to operating the vehicle check and adjust tire pressure to the proper operating pressure as indicated on the sidewall of each tire or in the Owners' Manual. A tire pressure gauge is required to obtain accurate readings. (15 PSI is recommended for 200 series)

**19. Check fuel supply before each use.**

- a. NEVER fill fuel tank while the engine is running or hot.
- b. DO NOT overfill tank.
- c. ALWAYS allow at least ½" of expansion space at the top of tank.
- d. There should not be any fuel in the filler neck.
- e. Replace cap tightly to prevent a fuel spillage fire hazard.

**NOTE: Always use an original gas cap or OEM (Original Equipment Manufacturer) replacement.**

- f. NEVER fill fuel tank while the vehicle is inside a building.
- g. After filling the tank, move the vehicle at least ten feet before attempting to start the engine.

**20. NEVER start the engine without the operator properly seated and the restraint system properly adjusted and secured with the brake applied and the vehicle in neutral (if equipped).****21. Be sure the passenger restraint system (i.e. Seat Belt) is properly adjusted and fastened at all times during operation.**

- a. If the passenger restraint system is not properly used by the operator and/or passenger, loss of control and possible personal injury and/or vehicle damage may occur.

**22. When there is no passenger in the vehicle, the passenger seatbelt must be securely fastened within the vehicle.**

- a. If the passenger restraint system is not properly used by the operator and/or passenger, loss of control and possible personal injury and/or vehicle damage may occur.

**23. Keep the engine free of dirt and debris, especially in the throttle linkage area.****24. NEVER start the engine without checking to see that the throttle control is in idle position.****25. ALWAYS use extreme caution when starting the engine.**

- a. Hot engine, muffler, or drive components can burn on contact.

**26. NEVER operate the machine while under the influence of alcohol, drugs, or medication of any kind.**

- a. Such operation is dangerous to yourself and/or others.

**27. NEVER use hand held electronic devices while driving this vehicle.**

- a. Driving while distracted can result in loss of vehicle control, accident and injury.

**28. Long hair, loose clothes, or jewelry can get caught in moving parts below and behind the seat or surrounding environment.**

- a. Remove or tie back anything loose that can reach below and behind the seat before riding.

**WARNING****WHILE OPERATING THIS VEHICLE!**

- 29. NEVER place hands, feet, or any body parts or clothing near the engine, wheels, chain, and other rotating parts of the vehicle while riding or running the engine.**
- Use caution in performing required maintenance on or near operating engine.
  - Use caution after the engine has been running, since the engine and other drive components may be extremely hot.
- 30. Wet, slippery, rough, or sloped terrain is potentially dangerous and may result in injury if proper caution is not observed.**
- ALWAYS SLOW DOWN
  - Operator must use mature judgment, skill, and experience to choose a speed suitable for terrain and riding conditions in protecting operator, passenger, and/or any bystanders.
  - Operator must use mature judgment, skill and experience in choosing suitable terrain for individual operational capabilities.
- 31. ALWAYS SLOW DOWN when turning.**
- This vehicle is not a passenger car. High-speed turning and failure to operate this vehicle correctly may cause loss of control, vehicle rollover and/or possible death or injury to the vehicle occupant(s).
  - Turning on a slope increases the risk of rollover.
  - Practice driving in a safe open area to develop a feel for the vehicles performance and handling characteristics, size and weight.
- 32. When turning on pavement, loose gravel, or similar surfaces, there is an increased risk in loss of control. \*\* ALWAYS SLOW DOWN! \*\***
- 33. Operating the vehicle in conditions where water, mud, snow, dirt, sand, or other debris can get into the throttle cable conduit and/or on the throttle mechanism may cause binding of the cable and/or the throttle mechanism.**
- This may result in the throttle sticking which can cause the engine to continue to run and result in loss of control.
- 34. Keep hands, feet, and all body parts in the vehicle at all times.**
- 35. STOP the vehicle and back slowly down any hill that the vehicle lacks the power or traction to climb. Do NOT turn across the slope or try to turn around.**
- Turning on a slope increases the risk of rollover.
  - Control the descent speed with the brake (left foot pedal).
  - Re-applying the throttle when facing up a steep hill increases the risk of the front tires leaving the ground and the vehicle over-turning.
- 36. STOP the engine if the machine makes unusual noises or vibrations.**
- Check the vehicle for damage.
  - Excessive noise or vibration is a sign of loose or worn parts.
  - Do not attempt to use the vehicle until it has been serviced to correct the issue.

**CAUTION**

- Vehicle must be stored where gasoline fumes will not reach an open flame, spark, or other source of ignition.*
  - For long-term storage, fuel tank should be drained in an open, cool area.*
  - Engine must be allowed to cool before storage in any enclosure.*
  - NEVER store the Utility Vehicle in close proximity to appliances such as hot water heaters or furnaces.*
- NEVER use E-15 or E-85 fuel or blends with Ethanol content in excess of 10%. Ethanol blends in excess of 10% will cause damage to the engine and void manufacturer warranty*
  - Use regular unleaded 89 octane gasoline with up to a 10% ethanol blend.*
  - This engine supplied with this Utility Vehicle is NOT designed for Flex Fuel operation.*



## SAFETY LABELS

### ⚠ WARNING

#### OBSERVE THE FOLLOWING INSTRUCTIONS

Failure to understand and follow Warnings and Instructions for the safe use and maintenance of this product may result in **Death or Injury!** This information is contained in the Warning Labels, Owner's Manual & Supplements, Safety Video, and Engine Manual supplied with this product. Make sure that you understand and follow all Warnings and Instructions in this material.

- Always wear a D.O.T.-approved motorcycle helmet, eye protection, and protective clothing.
- Reduce speed and use caution on slopes and in sharp turns.
- This vehicle is not to be operated by anyone under 16 years of age.
- **Do NOT** operate the vehicle without the brush bars securely in place.
- Keep all covers and shields properly installed.
- Never ride after consuming alcohol, drugs, or other intoxicants.
- Throttle and Brake Controls must work properly and freely before starting the engine.
- Operator must be seated, safety belt must be fastened before operating the vehicle.
- Never operate at speeds too fast for your skills or the conditions. Never attempt jumps or other stunts.
- Check tire pressures before operating. Refer to Owner's Manual for proper operating pressure.
- This vehicle is not street legal and is intended for off-road use only.



If you did not receive any of the material listed above, please call **800-643-7332** and request to have them sent to you at no charge.

2-60052 A

### ⚠ ADVERTENCIA

#### OBSERVE LAS SIGUIENTES INSTRUCCIONES

El hecho de no comprender y seguir las Advertencias y Instrucciones para el uso seguro y el mantenimiento de este producto puede causar **¡MUERTE O LESIÓN!** Esta información esta contenida en las Etiquetas de Advertencia, Manual de Dueño y Suplementos, Video de Seguridad, y el Manual del Motor proveídos con este producto. Asegúrese de comprender y seguir todas las advertencias e instrucciones suministradas.

- Siempre lleve puesto un casco de motocicleta aprobado por D.O.T., protección en los ojos, y ropa de protección.
- Reducir la velocidad y tenga cuidado en las pendientes y en curvas cerradas.
- Este vehículo no debe ser operado por ninguna persona menor de 16 años de edad.
- **NO opere** este vehículo sin las barras protectoras aseguradas en su lugar. Mantenga todos las cubiertas y protectores apropiadamente instalados.
- Nunca maneje después de consumir alcohol, drogas, u otros intoxicantes.
- Acelerador, y controles de frenos deben trabajar apropiada y libremente antes de encender el motor.
- El operador debe estar sentado, el cinturón de seguridad antes de operar el vehículo.
- Nunca opera a una. Nunca intente saltos o acrobacias. Sus habilidades o las condiciones.
- Checar inflación de llantas antes de operar. Consulte el Manual de Dueño para la presión adecuada de operación.
- Este vehículo no es legal en la calle y destinados a uso solamente afuera de carretera.



Si Usted no recibió alguno de los materiales mencionados anteriormente, por favor llame al **800-643-7332** y solicite que se le envíen sin cargo.

2-60052 AS

### ⚠ WARNING ADVERTENCIA



#### VEHICLE MAY ROLL

This vehicle will handle differently from any ordinary passenger car or truck. Sharp turns or abrupt maneuvers at high speeds may cause this vehicle to roll over or go out of control. Read and understand Owner's Manual before operating this vehicle.

#### EL VEHÍCULO SE PUEDE VOLCAR

Este vehículo se maneja y se maniobra diferente de cualquier otro carro o camión común de pasajeros. Curvas cerradas o maniobras bruscas en alta velocidad puede causar una volcadura o pérdida del control. Lea y comprenda el Manual de Dueño antes de operar este vehículo.

2-60052 B

### ⚠ CAUTION

#### DO NOT SHIFT WHILE IN MOTION

- D** To change gears, stop the vehicle. Shift with the engine at idle.
- N** Shifting gears with the engine speed above idle or with the vehicle in motion may cause
- R** transmission damage.

2-60052 L

### ⚠ PRECAUCION

#### NO CAMBIE DE VELOCIDAD MIENTRAS ESTE EN MOVIMIENTO

- D** Para cambio de engranes, detenga el vehículo, cambie con el motor desacelerado.
- N** Cambio de engranes con el motor acelerado por encima de lo normal o con el vehículo en movimiento puede causar daños a la transmisión.

2-60052 LS

### ⚠ CAUTION ⚠ PRECAUCION

#### SHUT OFF FUEL VALVE

Always shut off fuel valve before transporting this vehicle.

#### APAGE LA VÁLVULA DE COMBUSTIBLE

Todo el tiempo apague la válvula de combustible antes de que transporte este vehículo.

2-60052 C

### ⚠ WARNING ⚠ ADVERTENCIA

#### TURN OFF ENGINE

Always turn off engine before refueling. Refuel in a well ventilated area. Keep away from flame or sparks.

#### APAGE EL MOTOR

Todo el tiempo APAGE el motor antes de poner combustibles. Ponga combustible en un área bien ventilada. Aleje de las llamas o chispas.

2-60052 D

### ⚠ WARNING ⚠ ADVERTENCIA

#### LATCH DUMP BED

Driving with the cargo bed raised is hazardous. Always lower and latch bed before driving.





#### SEGURO DE LA CAJA DE VOLCAR

Manejar con la caja de carga levantada es peligroso. Todo el tiempo manténgala abajo y use el seguro de la caja cuando maneje.





2-60052 I

# SAFETY LABELS

<b>⚠ WARNING</b>	<b>⚠ ADVERTENCIA</b>
 <p><b>ALWAYS WEAR SEATBELT</b> Seatbelt must be properly fastened and adjusted for each occupant prior to operating the vehicle; See Operator's Safety Manual.</p>	<p><b>SIEMPRE USE CINTURON DE SEGURIDAD</b> El cinturón de seguridad debe ser apropiadamente atado y ajustado para cada ocupante antes de la operación del vehículo; Ver Manual de Dueño.</p>
2-60052 E	

<b>⚠ WARNING</b>	<b>⚠ ADVERTENCIA</b>
 <p><b>HOT SURFACES</b> Surfaces around the engine and exhaust can be extremely hot. Allow surfaces to cool before servicing.</p>	<p><b>SUPERFICIES CALIENTES</b> Las superficies alrededor del motor y el escape pueden estar extremadamente calientes. Permita que las superficies se enfríen antes de realizar el mantenimiento.</p>
2-60052 F	

<b>⚠ WARNING</b>	<b>⚠ ADVERTENCIA</b>
 <p><b>EXHAUST GAS HARMFUL</b> Engine exhaust from this product contains chemicals, known in certain quantities to cause cancer, birth defects, or other reproductive harm.</p>	<p><b>GASES DE ESCAPE NOCIVOS</b> Gases de motor de este producto contienen productos químicos, conocidos que en determinadas cantidades pueden causar cáncer, defectos de nacimiento u otros daños reproductivos.</p>
2-60052 G	

<b>⚠ CAUTION</b>	<b>⚠ PRECAUCION</b>
<p><b>USE ONLY MID-GRADE UNLEADED GASOLINE (89 – 93 OCTANE)</b> This engine is designed to run on automotive gasoline. NEVER use E-15 or E-85 fuel (diesel) or blends with an Ethanol content in excess of 10%. Doing so will cause damage to the engine and void the warranty.</p>	<p><b>USE SOLO GASOLINA DE MEDIO-GRADO SIN PLOMO (OCTANO 89-93)</b> Este motor ha sido diseñado para correr con gasolina automotriz. NUNCA utilice sustantivo E-15 o E-85 (diesel) o mezclas conteniendo Ethanol en exceso de 10%. El hacer esto ocasionara daño al motor y la garantía será anulada.</p>
 	 
2-60052 H	

<b>⚠ WARNING</b>	<b>⚠ ADVERTENCIA</b>
<p><b>WEAR A HELMET</b> Always wear a helmet when riding this vehicle.</p>	<p><b>USAR UN CASCO</b> Siempre use un casco al montar este vehículo.</p>
2-60052 K	

<b>⚠ WARNING</b>	<b>⚠ ADVERTENCIA</b>
 <p><b>NO RIDERS</b> All occupants must be inside the vehicle and wearing the proper restraints and safety gear.</p>	<p><b>NO SUBIR</b> Todos los ocupantes deben estar adentro del vehículo usando equipo de seguridad y restricciones adecuadas.</p>
2-60052 J	

<p>MAXIMUM WEIGHT: <b>250 Lbs</b></p>	<p>PESO MÁXIMO: <b>113 Kg</b></p>
---	---------------------------------------

<p>MAX TONGUE WEIGHT: 75 Lbs MAX TRAILER WEIGHT: 500 Lbs</p>	<p>PESO MÁXIMO DE LENGÜETA: 34 Kg PESO MAXIMO DE REMOLQUE: 226 Kg</p>
--	---

## SOME WORDS ABOUT RESPONSIBLE OPERATION AND RIDER SAFETY

The following pages present important information and recommendations to help you operate your vehicle responsibly and safely. Forming good habits and developing driving skills is an ongoing process. Even if you are an experienced driver, take time to become familiar with the controls, handling characteristics, capabilities, size and weight of your vehicle. Please read through these pages thoroughly.

### Qualifications for Vehicle Users

This light utility vehicle is restricted to use by operator and passenger with a **minimum age of sixteen (16) years** as indicated on the vehicle and vehicle specific literature. Light utility vehicles are intended for use by operators who meet the physical and cognitive capabilities set out by the manufacturer in this manual and in the material provided with the vehicle.

### CONSUMER RESPONSIBILITY FOR SAFE USE AND MAINTENANCE OF A LIGHT UTILITY VEHICLE

- 1. Vehicles shall not be modified from the manufacturer's original design and configuration.**
- 2. Vehicles shall not be used to perform racing, stunt riding, jumps, spinouts, donuts, or other maneuvers as they may cause loss of control. As such, these activities are likely to result in possible injury to the operator, passenger, bystanders, or all.**
- 3. Prior to each use, the operator shall perform the pre-operational checks specified by the manufacturer, and further verify:**
  - a. Smooth throttle operation and positive return of the throttle linkage to a closed throttle position when released;
  - b. That the throttle cable and linkages operate properly and the throttle cable or other linkages are adjusted properly;
  - c. That the steering mechanism(s) is adjusted and operates smoothly;
  - d. That the engine stop switch is properly functioning;
  - e. That all guards originally supplied by the manufacturer are in proper place in serviceable condition;
  - f. That engine idle speed is below the point of clutch or torque converter engagement;
  - g. That the gas tank is in good condition and the proper gas cap is fastened securely;
  - h. That the braking system is functioning properly;
  - i. That all safety labels are in place, legible and understood;
  - j. That any and all axle guards, chain guards, torque converter covers, or other covers or guards supplied by the manufacturer are in place and in serviceable condition;
  - k. That tires are in good condition, inflated properly, and have sufficient tread remaining; and
  - l. That all fasteners are in place and tightened securely.
- 4. Vehicle engines shall not be started unless the operator is seated and restrained in proper position for vehicle operation and the brake is fully engaged and the park brake applied.**
- 5. Long hair, loose clothes, or jewelry can get caught in moving parts below the seat or surrounding environment. Remove or tie back anything loose that can reach below or behind the seat before riding.**
- 6. Vehicles shall only be fueled by an operator knowledgeable with regard to proper fuel selection and fueling techniques.**
- 7. All operators and passengers shall be knowledgeable, capable, and has the cognitive capacity to operate the Vehicle safely, including those items specified in 1 through 6.**
- 8. Vehicle operators and passengers shall adhere to all manufacturer's recommendations and instructions, as well as comply with all laws and ordinances, and the following:**
  - a. Operators shall stay seated with both hands on the steering wheel and both feet in the vehicle at all times, whether moving or stationary, unless the vehicle is stopped completely and the engine has been shut off.
  - b. Passengers shall remain seated with arms and legs inside the vehicle at all times during Vehicle operation.
  - c. Shall observe minimum age restrictions.
  - d. Shall not ride the vehicle if long hair, loose clothes, or jewelry reach below or behind the seat.
  - e. Shall not allow smoking in the vehicle.
  - f. Persons under the influence of drugs, alcohol, or intoxicants shall not supervise, operate, or ride in the vehicle.

- g. Vehicles shall operate only on a surface or terrain recommended by the Vehicle's manufacturer.
- h. Vehicles shall not be operated on roads, streets, highways, or any other location where road vehicles are intended to travel.
- i. Vehicles shall be operated only with adequate lighting and under conditions of suitable visibility.

**9. Persons with the following conditions shall not ride in or operate a Vehicle:**

- a. Those with heart conditions
- b. Pregnant women
- c. Persons with head, back, or neck ailments, or prior surgeries to those areas of the body.
- d. Persons with any mental or physical conditions, which may make them susceptible to injury or impair their physical dexterity or mental capabilities to recognize, understand, and perform all of the safety instructions, and be able to assume the hazards inherent in vehicle use.

**10. Vehicle shall not be used to:**

- a. Transport a passenger except in the seating area provided.
- b. Transport materials or equipment in excess of the rated cargo capacity.
- c. Transport animals.

**11. Operator and any passengers shall always use appropriate protective clothing, including but not limited to a motorcycle helmet and eye protection, with appropriate certification, gloves, footwear, long sleeve shirts, and long pants.**

**12. No operator or other person shall contact any portion of the engine, wheels, or drive train for any purpose including maintenance until the engine has been turned off and allowed to cool, and the vehicle is in a stable and stationary position.**

**13. Passenger restraints must be used in accordance with, and limited to, the manufacturer's guidelines.**

**14. Vehicle components shall be maintained and repaired in accordance with the manufacturer's specifications and utilizing only the manufacturer's authorized replacement parts with installation performed by designated dealers or other skilled persons.**

## **WARNING**

### **WARNING**

*Long hair, loose clothes, or jewelry can get caught in moving parts below and behind the seat or surrounding environment. Remove or tie back anything loose that can reach below or behind the seat before riding.*

## **OFF-ROAD USE ONLY**

Your vehicle and its tires are designed and manufactured for off-road use only and not for use on paved surfaces. Driving on paved surfaces can affect the vehicle handling, control, and cause excessive wear to your tires.

When driving off-road, also remember to always obey local off-road driving laws and regulations. Obtain permission to drive on private property. Avoid posted areas and obey "NO TRESPASSING" signs.

You should never drive your vehicle on public streets, roads or highways, even if they are not paved. Drivers of street vehicles may have difficulty seeing and avoiding you, which could lead to a collision.

## **WARNING**

- *Operating this vehicle on paved surfaces may seriously affect handling and control of the vehicle, and may cause the vehicle to go out of control.*
- *Operating this vehicle on public streets, roads or highways could result in a collision with another vehicle. This vehicle is not street legal and should never be operated on any public streets, roads or highways, whether they are dirt, gravel or paved surfaces.*

## KEEP HANDS AND FEET ON CONTROLS

When driving your vehicle, always keep both hands on the steering wheel and feet in proximity of the foot controls. It is important to remain alert and remain focused when driving the vehicle. Removing hands from or feet away from the controls can reduce your ability to react and maintain control of the vehicle.

### **! WARNING**

- *Removing your hands from the steering wheel or feet away from the foot controls during operation can reduce your ability to control the vehicle and could result in a collision. Always keep both hands on the steering wheel and both feet in proximity of the foot controls of your vehicle during operation.*
- *Keep hands, feet, and all body parts in the vehicle at all times.*
  - *In the event of a vehicle roll-over, do NOT extend arms, legs or any other extremity outside the vehicle as possible personal injury can occur.*

## CONTROL SPEED

Driving at excessive speeds increases the likelihood of an accident. In choosing an appropriate speed, you must consider the capability of your vehicle, the terrain, visibility and other operating conditions, in addition to the skill and experience of the driver.

### **! WARNING**

*Operating this vehicle at excessive speeds increases your chances of losing control of the vehicle, resulting in an accident. Always drive at a speed that is appropriate for your skill, your vehicle, the terrain, visibility and other operating conditions.*

## USE OF THIS VEHICLE ON UNFAMILIAR OR ROUGH TERRAIN



Before driving in an unfamiliar area, always check the terrain thoroughly. Don't drive fast on unfamiliar terrain or when visibility is limited (it is often difficult to react to hidden obstructions like rocks, bumps, or holes).

Never drive past the limit of visibility. Maintain a safe distance between your vehicle and other off-road vehicles. Always exercise caution and use extreme care on rough, slippery and loose terrain.

### **! WARNING**

- *Failure to use extra care when operating this vehicle on unfamiliar terrain could result in the vehicle overturning or going out of control. Go slowly and use extreme caution when operating on unfamiliar terrain. Always be alert to changing terrain conditions when operating the vehicle.*
- *Failure to use extra care when operating on excessively rough, slippery or loose terrain could cause loss of traction or vehicle control, resulting in an accident or overturn. Do not operate on excessively rough, slippery or loose terrain until you have learned and practiced the skills necessary to control the vehicle on such terrain. Always be especially cautious on these types of terrain.*
- *STOP the vehicle and back slowly down any hill that the vehicle lacks the power or traction to climb. Do NOT turn across the slope or try to turn around.*
  - Turning on a slope increases the risk of rollover.*
  - Control the descent speed with the brake (left foot pedal).*
  - Re-applying the throttle when facing a steep up-hill increases the risk of the front tires leaving the ground and the vehicle over-turning.*

**DO NOT PERFORM STUNTS**

You should always operate your vehicle in a safe and reasonable manner. When driving, always keep all four wheels on the ground.

**⚠ WARNING**

*Attempting wheelies, jumps, and other stunts increase the chances of an accident, including an overturn. Never attempt stunt riding of any type and ride responsibly. Don't try to show off.*

**⚠ WARNING**

*Operating this vehicle without your seat belt could cause you to be thrown from the vehicle, causing serious injury or death.*

**NO ALCOHOL OR DRUGS**

Alcohol, drugs, and utility vehicles **DO NOT** mix. Even a small amount of alcohol can impair your ability to operate utility vehicles safely. Likewise, drugs, even if prescribed by a physician, can be dangerous while operating a utility vehicle. Consult your doctor to be sure it is safe to operate a utility vehicle after taking medication.

**⚠ WARNING**

*Operating this vehicle after consuming alcohol or drugs can seriously affect your judgment, cause you to react more slowly, affect your balance and perception, and could result in serious injury or death. Never consume alcohol or drugs before or while operating this vehicle.*

**IS YOUR VEHICLE READY TO DRIVE?**

Before each drive, it is important to inspect your vehicle and make sure any problems you find are corrected. A PRE-RIDE INSPECTION is a must, not only for safety, but because having a breakdown, or even a flat tire, can be a major inconvenience.

Perform a PRE-RIDE INSPECTION using the list provided at the back of this book before each use to ensure that your vehicle is in proper working order.

Correct any discrepancies according to this Operator's Safety Manual before riding. If the problem cannot be corrected, contact an authorized dealer for assistance or call 1-800-643-7332 for Customer Service.

If your vehicle has overturned or has been involved in a collision, do not drive it until your vehicle has been inspected by your dealer. There may be damage or other problems that you cannot see

**⚠ WARNING**

*Improperly maintaining this vehicle or failing to correct a problem before driving can cause an accident resulting in serious injury or death. Always perform a pre-drive inspection before every drive and correct any problems.*

## ARE YOU READY TO DRIVE?



Before each drive, you need to make sure that you, along with your vehicle, are ready to drive. To help get you prepared, this section discusses how to evaluate your driving readiness. Before you drive your vehicle for the first time, we urge you to:



- Read this owner's manual and the labels on your vehicle carefully.
- Make sure you understand all the safety messages.
- Know how to operate all the controls.

### Protective Apparel

Although complete protection is not possible, wearing proper gear can reduce the chance of injury should you have an accident. The following suggestions will help you choose the proper protective gear.

#### • Helmet and Eye Protection

- Your helmet is your most important piece of protective gear because it offers the best protection against head injuries. A helmet should fit your head comfortably and securely.
- Open-face helmets offer some protection, but a full-face helmet offers more. Regardless of the style, look for a D.O.T. (Department of Transportation) or Snell Memorial Foundation (SNELL) sticker on any helmet you buy. Always wear a face shield or goggles to protect your eyes and help your vision.

#### • Additional Driving Gear

- Sturdy boots, such as an off-road motorcycle boot, to help protect feet, ankles, and lower legs.
- Gloves, such as off-road motorcycle gloves, to help protect your hands.
- Long pants, preferably with knee and hip pads, and a long-sleeved shirt or jacket, preferably with padded elbows and a chest protector.

## ! WARNING

- *Operating this vehicle without wearing an approved motorcycle helmet, eye protection, and protective clothing could increase your chances of head and/or eye injury, and the possibility of death in the event of a severe accident.*
- *Always wear an approved motorcycle helmet that fits properly and wear eye protection (goggles or face shield), gloves, boots, long-sleeved shirt or jacket and long pants.*

## TRAINING AND DRIVER DEVELOPMENT

Developing good driving skills is an ongoing process. Even if you are an experienced driver, take time to become familiar with the controls and how the vehicle handles. Practice driving in a safe, open area to develop your skills. Do not drive on rough terrain until you get accustomed to the vehicle controls and feel comfortable with its size and weight.

Inexperienced drivers of specified age must be supervised and should practice in an open, uncongested area.

# LIGHT UTILITY VEHICLE OPERATION

## OPERATION CONTROLS

### **WARNING**

*Do not attempt to start or operate the engine until completely familiar with the location and use of each control necessary to operate this vehicle. The operator must know how to stop this machine before starting and driving it.*

#### **A. THROTTLE**

The right foot pedal is the throttle and controls the speed of the vehicle. As the engine speed increases above idle, the clutch automatically engages and moves the vehicle forward. To disengage the clutch at any time, allow the throttle to return to the idle position.

### **WARNING**

*Every time, prior to starting the engine, check the throttle assembly to ensure that when the pedal is pushed all the way forward the assembly is working smoothly and returns to idle when released. Do not operate this unit if pedal or engine throttle linkage fail to return to the idle position. If unable to correct the problem through lubrication, adjustment or replacement of worn parts, contact your dealer for assistance.*

#### **B. BRAKE**

The service brake is controlled by the left foot pedal. Applying pressure to the pedal draws the brake pads against the brake discs at the wheels and slows or stops the vehicle. There is an additional park brake feature that should remain applied anytime the vehicle is parked including during starting and engine warming. See Park Brake for more instruction.



#### **C. PARK BRAKE**

This vehicle is equipped with a parking brake system. The parking brake lever can be found in front of the passenger seat just under the dash. To apply the brake, simply depress the brake pedal and pull back on the parking brake lever, locking it into position. To disengage, depress the pedal, push the thumb button located at the top of the lever and return to its original position towards the front of the vehicle. The park brake should be applied during starting, engine warming, and anytime the vehicle is parked and/or left unattended.



#### **D. OCCUPANT RESTRAINTS**

This vehicle is equipped with automotive style 3 point retracting seat belts. Insert the metal tongue into the buckle until it is securely attached. Final adjustments should be made with the plastic tension stop such that the belt is against the shoulder and chest with no excess slack. This vehicle is also equipped with a passenger grab bar located on the dash directly in front of the passenger seat

### **WARNING**

*Operating this vehicle without your seat belt could cause you to be thrown from the vehicle, causing serious injury or death.*



#### **E. LIGHTS**

Depending on your specific model, the vehicle may be equipped with any one or combination of the following: front running lights, a rear running/brake lamp, a rear facing cargo light. To turn the running lights on, flip the lower switch located next to the keyed ignition on the dashboard of the unit. The cargo light can be turned on by flipping the upper switch located next to the keyed ignition. The rear brake light will activate automatically when the brake pedal is depressed.



**F. POWER OUTLET**

This vehicle also is equipped with a 12V, 10amp power outlet for plugging in accessory items, and comes standard with a rubber cap. Do not exceed the maximum amperage rating of the plug.

**G. ENGINE STARTING**

For added security, this unit is equipped with a keyed ignition switch. As an added feature, all lights are turned off when the key switch is in the “OFF” position. The keyed ignition will only start the engine when brake pedal is depressed. Turn the fuel valve “ON”. Place the unit in the NEUTRAL gear. Fasten seatbelt, place one foot on the



brake pedal and set the park brake. Pump the throttle pedal several times to ensure that the pedal operates and returns smoothly. Apply choke by pulling out and holding the choke cable located on the dash to the right of the ignition switch. Turn ignition key fully clockwise and hold to start the engine. (Caution: Do not let the engine turn over for more than 5 seconds at a time as this may cause starter damage). Once the engine starts, allow the key to return to the run position. Adjust the choke by pushing it in slowly. If the engine starts to run rough, pull the choke control out slightly and then continue to push the choke control in after the engine can accept small applications of the gas pedal. Continue this process until the choke control is pushed all the way in (fully “OFF”).

This may require a period of several seconds to several minutes, depending on the air temperature. For example, at a temperature of 70° F, the choke period is approximately 30 seconds. Before driving this vehicle, test that the ignition switch will turn off the engine. With the engine running, turn the ignition key counter-clockwise to the “OFF” position to shut down the engine. An already “warm” engine will not require the use of the choke in the starting process. Return the fuel valve to the “OFF” position when the vehicle is not in use.

**H. CHOKE**

The choke is used to assist in cold engine starting. The choke is “ON” when the knob is pulled out completely and “OFF” when the knob is pushed in completely. An already “warm” engine will not require the use of the choke in the starting process.

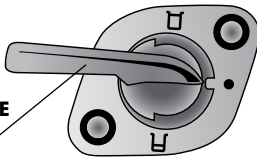
**I. FUEL VALVE**

The manual valve is mounted to the bottom of the fuel tank and provides the added feature of a “reserve” position which provides access to a reserve fuel supply allowing additional driving range to get to a fuel filling station should the main fuel supply be used completely.

**NOTE: Turn fuel valve to OFF position during transport.**

**F  
N  
R** **J. GEAR SELECTION**

This vehicle is equipped with a Drive / Neutral / Reverse transmission. To shift gears, bring the vehicle to a complete stop and let the engine RPM stabilize to the idle level. With the brake applied, move the shift lever to the desired gear, release the brake, and gently depress the throttle pedal.

**! CAUTION**

*Damage to the vehicle will occur if the unit is shifted into a different gear while the vehicle is still in motion. ALWAYS bring the vehicle to a complete stop and let the engine RPM stabilize to the idle level before selecting a different gear.*

**K. SEAT ADJUSTMENT**

The unit is equipped with an adjustable seat. To adjust, lift the levers just in front of the seat bottom and move the seat either forward or backward. Release the levers at the desired seat location, ensuring that they both snap back into place to lock the seat in position.

**! WARNING**

*Never operate this vehicle when the seat is not securely locked into position. Serious injury or death could occur due to loss of control. Always make seat adjustments with the vehicle fully stopped and the engine shut off.*

**L. CARGO DUMP BED – 250 lb MAX LOAD**

This vehicle is equipped with a manual rear dump cargo bed. Release levers are located on both the driver and passenger sides of the vehicle. Loose cargo should be secured with a cargo net, or proper cargo straps to prevent shifting during transport. This bed is NOT designed to transport people or animals and should be used for hauling cargo only. Prior to dumping any loads, the parking brake should be applied and the keyed ignition turned to the “OFF” position. To dump the bed, lift the tailgate to remove it, stand to the side of the unit, pull the release lever upwards, and manually tilt the bed to dump the load. After dumping, the bed should be securely latched and the tailgate reinstalled.

**! WARNING**

*Do not lean over the bed while releasing the bed latch. Loads shifted towards the tailgate may cause the front of the bed to suddenly raise when unlatched causing serious injury.*

**! CAUTION**

*Ensure that the bed is securely latched before driving the unit. Failure to properly latch the bed may result in damage to cargo, or to the unit.*

**M. TAILGATE REMOVAL**

To remove the tailgate, simply lift up. To reinstall the tailgate, insert the tailgate into the guide slots and push down until you feel the tailgate engage the retention detents

**N. DRAWBAR HITCH - 500 lb MAX LOAD (Rolling)**

This vehicle may be equipped with a drawbar style hitch for towing light utility carts, non-ground engaging lawn equipment, and various attachments. Pull behind mower decks are not approved for use with this vehicle because the partial throttle / slow travel speed required causes continuous CVT clutch slippage and pre-mature drive train wear. This drawbar is NOT designed to accept equipment with hitch ball type tongues. Drawbar hitch is designed for 75 lb maximum tongue weight.

**! CAUTION**

*Ensure that towed items fall within the listed load ratings AND are approved devices. Exceeding the rated load, or using unapproved devices, will cause damage to both the drawbar hitch and engine drive-train that is not covered by warranty.*

## FUELING YOUR VEHICLE

The fuel tank is located directly behind the passenger seat on this vehicle and can be filled from either the front or back of the fuel tank. To aid in filling, it may be beneficial to either unlatch and lift the dump bed, or adjust the seat forward. With the vehicle in a well-ventilated area, and following the warnings listed below, unscrew the fuel cap and fill the tank with a mid-grade unleaded gasoline (89-93 Octane). Replace the cap securely and secure the seat and/or dump bed as needed. **Note: If the manual fuel valve is being used in the “RESERVE” position, return the fuel valve to the “ON” position after refueling. If the valve is left in the “RESERVE” position you may run out of fuel and have no reserve.**

### **! WARNING**

Check fuel supply before each use.

- a. NEVER fill fuel tank while the engine is running or hot.
  - b. DO NOT overfill tank.
  - c. ALWAYS allow at least ½” of expansion space at the top of tank.
  - d. There should not be any fuel in the filler neck.
  - e. Replace cap tightly to prevent a fuel spillage fire hazard.
- NOTE: Always use an original gas cap or OEM (Original Equipment Manufacturer) replacement.**
- f. NEVER fill fuel tank while the vehicle is inside a building.
  - g. After filling the tank, move the vehicle at least ten feet before attempting to start the engine.

### **! CAUTION**

This engine is not designed for Flex Fuel operation. Attempting to use anything other than the mid-grade 89-93 octane automotive fuels will cause damage to the engine.

## VEHICLE FEATURES AND LOCATIONS

### DASH AREA

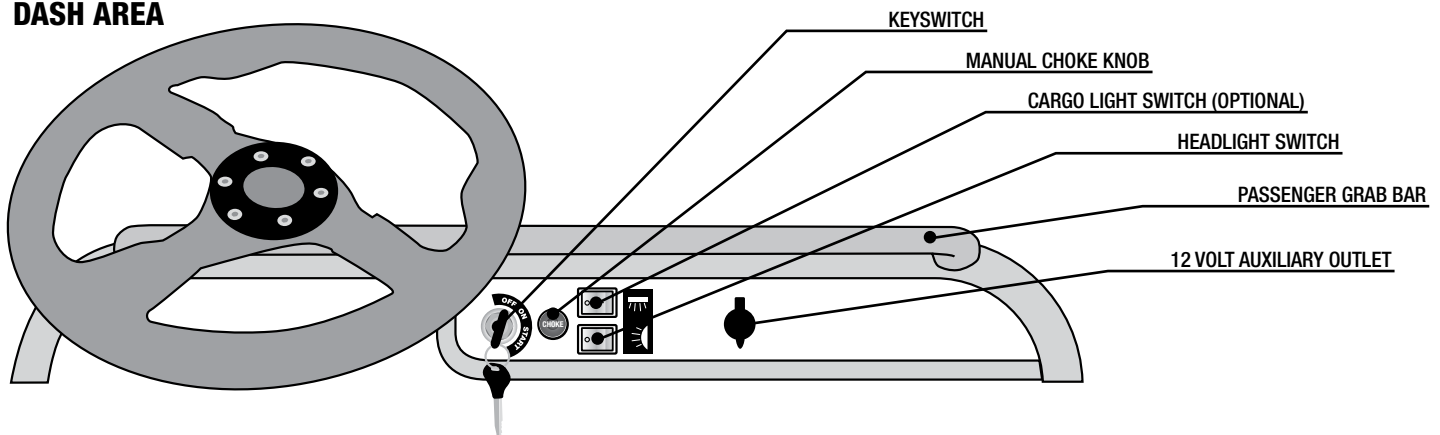

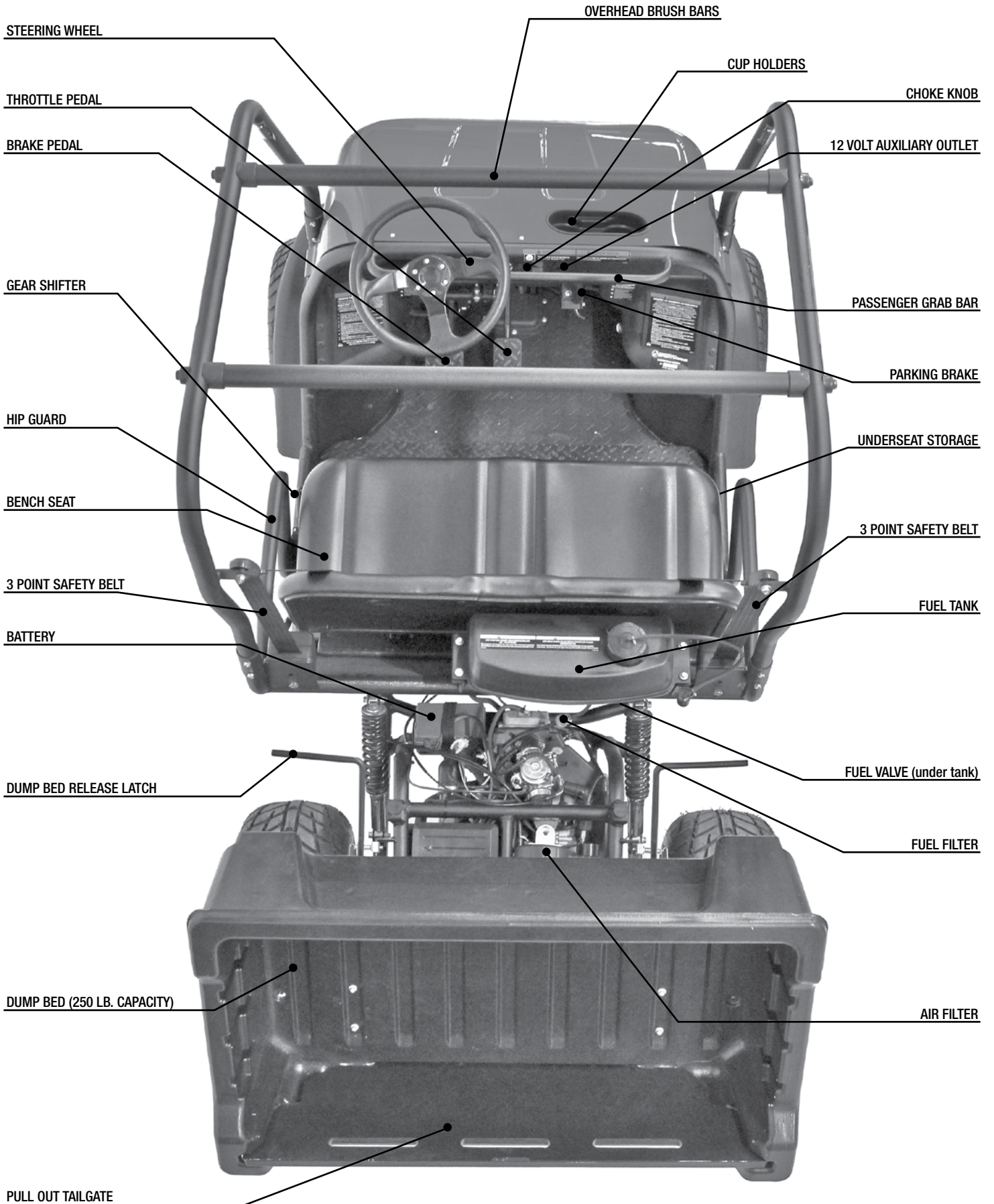

## REPLACEMENT PARTS & SERVICE

Most replacement parts are typically available from your dealer. Because of immediate availability and convenience, it is recommended that replacement parts be ordered from an authorized dealer. Take this manual and all supplements to the dealer when ordering parts in person.

If replacement parts are not available from a dealer, they may be ordered directly from American SportWorks by contacting ASW at 1-800-643-7332 or at [www.amsportworks.com](http://www.amsportworks.com) where an on-line illustrated parts list can be found and orders placed. Orders may be subject to a minimum fee. A listing of authorized service center locations in your area is also available at [amsportworks.com](http://amsportworks.com) or from our Customer Service department.

Record the Vehicle Identification Number (VIN) in the spaces provided at the front of the Owners' Manual. The VIN is both hard tagged and in UPC symbol form and can be found on the crossbar, behind the seat.

### A. AIR CLEANER

This unit is equipped with a paper style air filter element and should be replaced after every 20 hours of operation (Ref Figure). The air box assembly is part of the engine swing-arm and is located on the passenger side of the unit under the cargo bed

**NOTE: Operation in unusually dusty conditions may require more frequent replacement.**

- Removing the entire air box assembly from the vehicle is the most effective way to change the air filter element (3). This is done by using a flat head screwdriver to loosen the band clamp that secures the air duct (1) to the carburetor, using a 10mm wrench to remove one fastener that attaches the air filter base (2) to the swing arm tube and one fastener that attaches the air box cover (4) to an engine backing plate, and then maneuvering the entire assembly out of the swing arm.
- Remove the air box cover (4) by using a Phillips head screwdriver to remove five screws.
- Clean any excess dirt, oil, or dust from both the air filter base and air box cover with a mild detergent and water solution.
- Thoroughly dry the air box assembly.
- Replace the air filter element (3).
- Re-assemble and re-install the air box assembly by reversing these directions being careful to properly align the air box halves during re-assembly, install the air duct over the carburetor air intake and secure it, and complete a final inspection of the air box assembly (especially the air duct since it is "downstream" of the air filter element) for any damage. Make corrections as necessary and replace any parts that are found to be damaged to prevent dust and dirt from contaminating the engine.

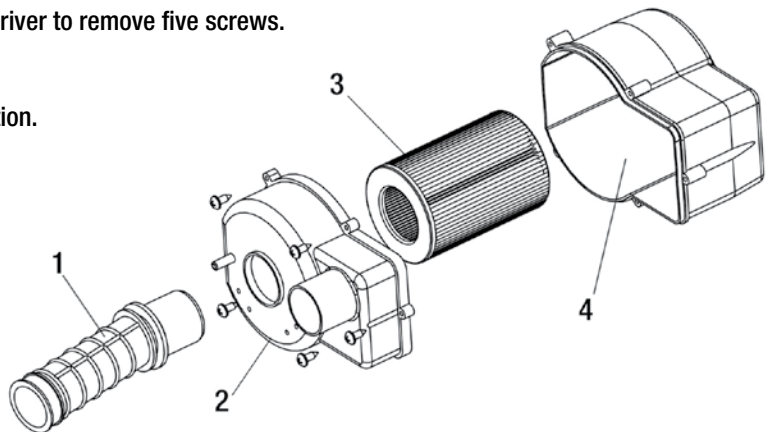

### B. ENGINE LUBRICATION

You **MUST** change the oil in the crankcase after the first 5 hours of operating a new engine. The engine oil should then be changed every 20 hours of use thereafter. This will insure proper lubrication of the internal parts and prevent costly repairs due to excessive wear.

#### **CAUTION**

*This unit has been shipped with special BREAK-IN oil pre-filled in the engine crankcase. This oil MUST be changed after 5 hours of operation. Replace with SAE 10W40 weight motor oil as described in the following section.*

#### **WARNING**



*Used oil MUST be disposed of at a proper collection center.*

## B. ENGINE LUBRICATION (cont.)

- Remove the Drain Plug located on the bottom of the right rear side of engine. Elevating the front of the vehicle slightly will help drain all of the oil.
- The oil should be emptied into suitable container for recycling.
- Remove and clean the oil screen.
- With the oil completely drained, replace the screen and drain plug, and tighten securely.
- Place the vehicle back onto a flat surface to level the engine, and re-fill the crankcase with 30oz of SAE 10W40 motor oil.
- Check the oil level using the dipstick attached to the oil plug cap. Be sure to check the oil level before each use of the vehicle. Add oil when necessary to keep the oil level between the bottom of the dipstick and the "O" mark.

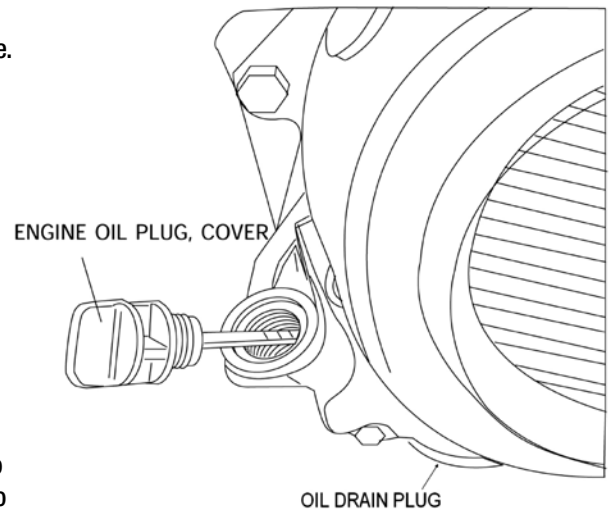

**NOTE:** Oil level should be checked by dipping the oil level stick into the crankcase **WITHOUT** screwing the cap in.

## C. SPARK PLUG

- Remove the spark plug and inspect it each time you change the oil (Use a spark plug wrench). The electrodes should be kept clean and free of carbon. The presence of carbon or excess oil will greatly reduce engine performance. If possible, check the spark plug gap (area between the electrodes) using a wire feeler gauge or spark plug gap tool.
- Correct gap is **0.6 - 0.7mm**.
- Before installing the spark plug, coat the threads lightly with graphite lubricant to ensure easier removal of the plug in the future.
- Spark plug should be replaced once a year for optimum engine performance.

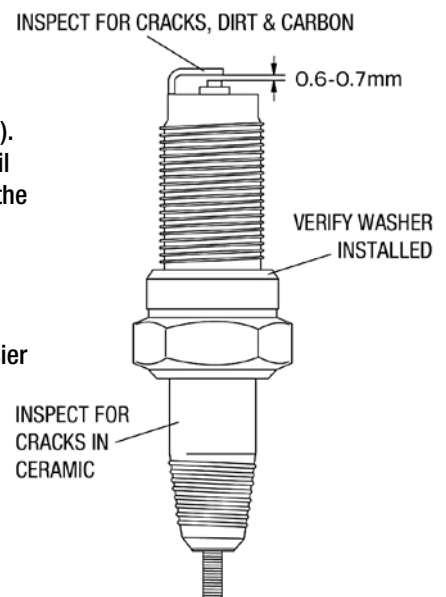

## D. CARBURETOR ADJUSTMENT

All the necessary carburetor adjustments have been made at the factory, and the recommended settings are correct for most applications. To adjust the engine idle setting on the carburetor:

- Start the engine per the starting instruction found in Section 3, Part G. ENGINE STARTING.
- Use an inductive tachometer or other suitable equipment to monitor engine speed and a Phillips screwdriver to adjust the idle screw (B) until the tachometer shows the engine has settled at 1600 to 1800 RPM.
- Drive the unit for 8-10 minutes to allow the engine to warm up.
- Use the tachometer to again check the idle speed and re-adjust if necessary.

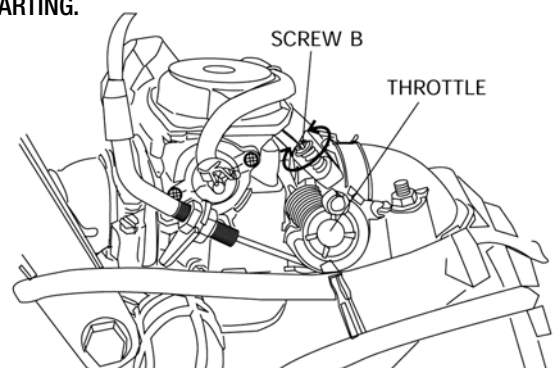

**NOTE:** For further carburetor adjustments, refer to the 150cc Engine Service Manual. The manual is available on our website at [amsportworks.com](http://amsportworks.com), by calling ASW's customer service or for purchase from your Dealer.

## E. CLEANING INSTRUCTIONS

Keep your vehicle clean by using a clean rag and a mild detergent and water solution. Wipe off all dirt and oil from around the controls. Wipe off any spilled fuel and oil. Keep the engine clean and clear of foreign objects, especially those around the engine cooling fan air intake and air inlet ductwork. Use of a high pressure power washer may damage paint, plastics or engine components and is not recommended for cleaning your vehicle.

## F. GENERAL LUBRICATION

Lubricate the vehicle at least every 90 days, and more often, if it is used daily or in unusually dusty conditions. Lubrication of the front suspension should be performed by adding fresh axle grease, with a grease gun, to the fittings located on each A-Arm.

## G. CHAIN LUBRICATION AND ADJUSTMENT

For optimum chain life, regular lubrication with a spray of chain lubricant should be performed on a regular basis. (Ref Figure below)

A new chain will have initial stretch and therefore will require adjustment. The first chain adjustment should be made after the first 2 hours of use. If the chain has more than 1/2" of slack or "flex" then it will require adjustment. To adjust:

- a. Loosen Nut (1).
- b. Adjust nut (2) on the underside of the tube.
- c. Re-tighten Nut (1)
- d. Repeat until the proper chain tension is achieved

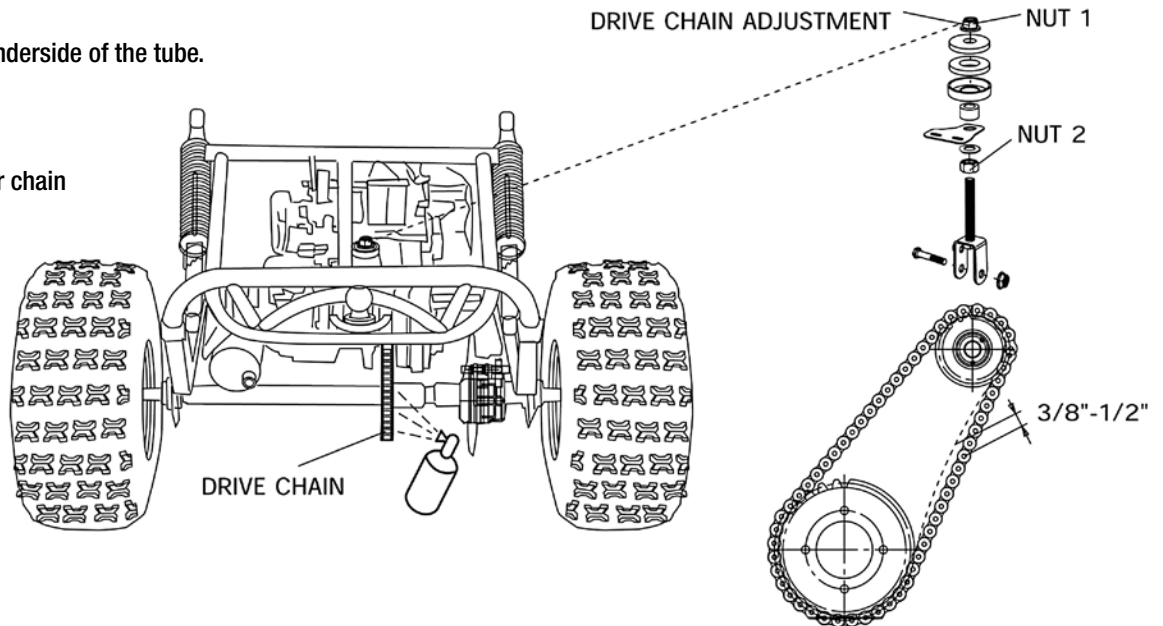

## H. ADJUSTMENT OF FRONT AND REAR SHOCK

There are five adjustable positions on each shock. The center notch is the default position as set by the manufacturer (Ref Figure). Use a round nut spanner wrench to adjust the shock.

- To **INCREASE** the shock stiffness, rotate the ring to the highest (longest) setting.  
 To **DECREASE** the shock stiffness, rotate the ring to the lowest (shortest) setting.

Shock stiffness adjustments should be made based on the overall weight of the rider, occupant and cargo.

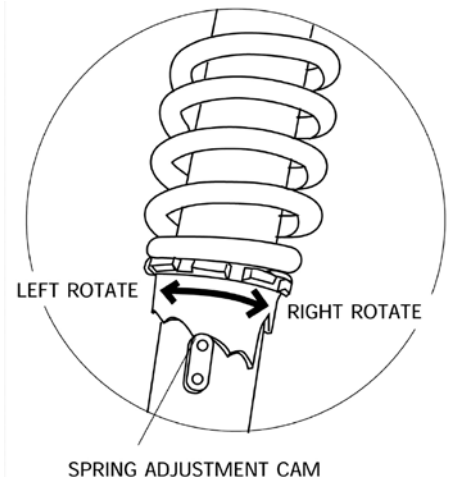

## I. CABLE LUBRICATION

Stiff or sticking cables can cause the vehicle to not operate properly. Before attempting to adjust the cables ensure they are lubricated. To lubricate the cables, slide the rubber dust caps up the cable. Drip or spray penetrating oil into the cable housing while working the cable. Do this several times as the oil soaks into the housing. Test the vehicle. If this did not help, the cable may require replacement.

**J. SHIFTER ADJUSTMENT**

Your unit may require an occasional adjustment in the shift cables due to typical stretch found during normal operation of the vehicle. To make shift adjustments, ensure that engine is off and spark plug cap is removed. Refer to the following procedure:

- a. Push the shift lever to the “D” position
- b. Check the restriction control disc found just behind the oil level dipstick to ensure that it has rotated forward all the way (looking for any slack in control cable #1)
- c. Loosen adjustment nuts #1 and #2, pulling the housing to draw the cable tight. Re-tighten the nuts when the cable is properly tensioned.
- d. Shift the lever to the “R” position and check the control disc to ensure that it has rotated full towards the rear of the vehicle.
- e. Loosen adjustment nuts #3 and #4, pulling the cable housing to draw the #2 control cable tight.
- f. Re-tighten nuts #3 and #4 when the cable is properly tensioned.

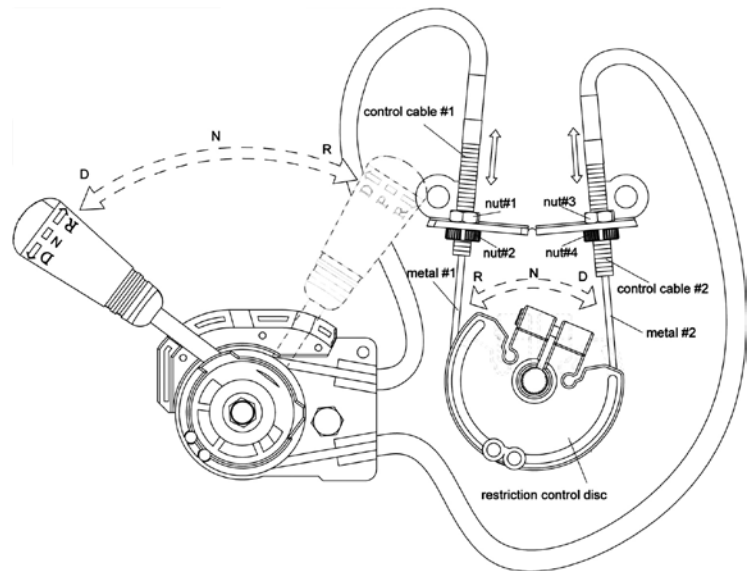
**K. STORAGE INSTRUCTIONS**

If you plan to store (and not operate) your vehicle for a period in excess of 30 days, or at the end of each driving season, the unit should be set up for storage as follows:

- a. Drain fuel tank and carburetor by allowing the engine to run completely out of fuel.
- b. Lubricate the engine cylinder by removing the air cleaner and spraying an engine fogging oil through the carburetor.
- c. Do **NOT** save or store gasoline over the winter. Using old gasoline, which will deteriorate from storage, will make the engine difficult to start and affect the performance of the engine.
- d. Remove the battery from the unit and apply a periodic trickle charge to maintain the battery at a proper voltage level for the next riding season.
- e. To protect the paint, plastics and upholstery, it is a good idea to keep the unit covered when not in use.

**CAUTION**

*If this unit is stored outside, the air box could collect rainwater. To prevent water from damaging the engine, any trapped water should be drained prior to each use by opening the drain tube located on the bottom side of the air box.*



## GENERAL MAINTENANCE

### **! CAUTION**

*Prevailing torque type locknuts must be replaced with new after the old locknuts are removed.*

#### **A. FRONT WHEEL REPLACEMENT**

Do not disassemble the castle nuts when you replace the front wheels. It is only necessary to remove the 4 lug nuts to remove the wheel. (See Figure) Tighten the nuts securely after replacing the wheels.

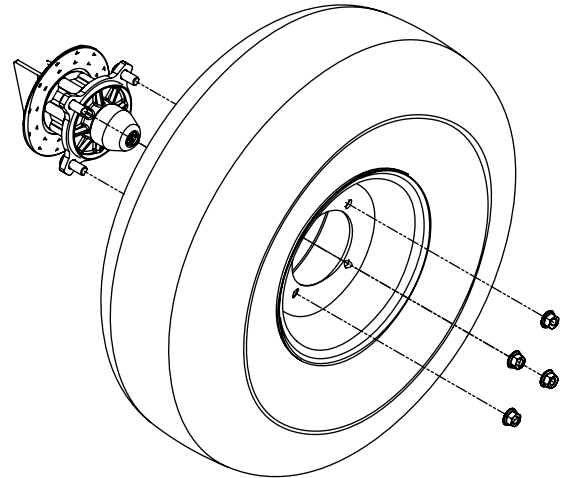

#### **B. REAR WHEEL REPLACEMENT**

Do not disassemble the castle nuts when you replace the rear wheels. It is only necessary to remove the 4 lug nuts to remove the wheel. (See Figure) Tighten the nuts securely after replacing the wheels

#### **C. FRONT WHEEL ALIGNMENT**

The front wheels should be set with a “toe-in” from 1/8” to 1/4”. At the centerline of the tires, measure the Distance A and the Distance B. For proper toe adjustment, Dimension A should be 1/8” – 1/4” **GREATER** than Dimension B.

To make adjustments:

- Loosen the lock nuts on both sides of Front Tie Rods.
- Ensure the steering wheel is centered, and adjust Dimension B by equally rotating the tie rods in or out with a 12mm wrench.
- After adjusting to the desired length, tighten the lock nuts against the rod end.
- Recheck the dimensions for proper alignment.

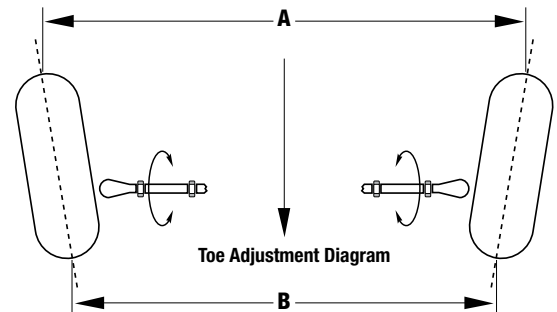

#### **D. FUSE REPLACEMENT**

Your unit is equipped with fuses to protect the electrical system from excessive load conditions. There is a main 10amp in-line automotive style blade fuse located on the smaller of the two wires coming directly from the battery’s positive terminal. It will be found approximately 5 inches along the wire measuring from the battery terminal end. A second 10amp inline automotive style blade style fuse is found behind the dash and protects the 12V power outlet. Replace either fuse by opening the fuse holder. Remove fuse and replace with known “good” fuse. Close the fuse holder.

#### **E. INTAKE CLEANING – ENGINE COOLING FAN**

Frequent driving in loose leaves, or freshly cut grass will tend to attract debris to the engine cooling fan air intake located on the passenger side of the engine just in front of the right rear tire (Ref Figure). This screen should be checked and cleaned frequently to allow fresh air to enter the cooling duct work. A clogged air intake will overheat the engine causing damage to internal components and will void the warranty.



Debris clogging the cooling fan

**F. OPTIONAL SPEED REDUCTION INSTALLATION**

This vehicle has been equipped with provision for a speed limiter to reduce the overall speed of the unit to approximately 20mph. This kit is available from your dealer or directly from American SportWorks by calling customer service.

To install the speed limiter:

- a. Remove the electrical control box cover located on the rear swing arm, just next to the air box, using a Phillips screwdriver.
- b. Locate the CDI (black box with 2 wire plugs)
- c. Unplug the old CDI and replace with the new Rev Limited CDI provided in the kit.
- d. Replace the electrical box cover, being careful not to damage or crush any wires and connections.

**NOTE: Keep the original CDI so that the vehicle can be changed back to the original factory setting if desired**

**PERIODIC CHECKS AND SERVICES**

The maintenance intervals in the following table are based upon average driving conditions. Driving in unusually dusty areas may require more frequent servicing.

ITEM	FIRST WEEK	MONTHLY	QUARTERLY	YEARLY
Idle Speed Adjustment	INSPECT	INSPECT		
Spark Plug			CLEAN / ADJUST	INSPECT
Tire Wear	INSPECT	INSPECT		
Brake Fluid and Performance	INSPECT	INSPECT		
Air Cleaner		INSPECT / REPLACE <i>(or after 20 hrs)</i>	INSPECT / REPLACE <i>(or after 20 hrs)</i>	REPLACE
Chassis Nuts & Bolts	INSPECT	INSPECT		
Fuel Switch (Petcock) / Fuel Filter		INSPECT		CLEAN / INSPECT / REPLACE
Final Gear Oil		INSPECT	REPLACE	
Engine Oil	REPLACE <i>(or after 5 hrs)</i>	REPLACE <i>(or after 20 hrs)</i>		
Chassis		CLEAN / INSPECT	LUBRICATE	
Carburetor	INSPECT	ADJUST		CLEAN
Valve Clearance			ADJUST	
Shifter Adjuster		INSPECT	CLEAN / ADJUST / LUBRICATE	
Battery	INSPECT		INSPECT	
Cables	INSPECT		ADJUST / LUBRICATE	

**G. CABLE LUBRICATION**

Stiff or sticking cables can cause the vehicle to not operate properly. Before attempting to adjust the cables ensure they are lubricated. To lubricate the cables, slide the rubber dust caps up the cable. Drip or spray penetrating oil into the cable housing while working the cable. Do this several times as the oil soaks into the housing. Test the vehicle. If this did not help, the cable may require replacement.

**THE MOST UP TO DATE ILLUSTRATED PARTS LISTS ARE AVAILABLE ONLINE  
AT AMSPORTWORKS.COM OR BY CALLING 800-643-7332**

### DIMENSIONS

Overall length ..... 2388mm (94.0 inch)  
 Overall width ..... 1245mm (49.0inch)  
 Overall height ..... 1784mm (70.25 inch)  
 Wheelbase ..... 1588mm (62.5 inch)  
 Track Width – Front / Rear ..... 1049mm (41.3 inch) / 1000mm (39.4 inch)  
 Ground Clearance ..... 170mm (6.7 inch)

### ENGINE

Type ..... Single cylinder oil & cooled 4 stroke  
 Engine displacement ..... 150cc  
 Bore x stroke ..... 57.4 x 57.8  
 Corrected Compression Ratio ..... 9.2: 1  
 Carburetor ..... DENI,JB24J  
 Output Power / Torque [N.m(r/min)-1] ... 9.0 hp @7500rpm / 13ft-lbs @ 5500rpm  
 Starting ..... Keyed Electric  
 Ignition ..... CDI  
 Lubrication ..... Cooled Force & Splash SAE-10W/40  
 Transmission ..... CVT Automatic with Neutral and Reverse  
 Spark Plug / Gap ..... Torch A7RTC / 0.6 – 0.7mm  
 Fuel Type ..... ONLY USE Mid-Grade Unleaded (89 - 93 Octane)

These specifications are subject to change without notice.

### CAPACITIES

Maximum Load (Driver, Passenger, & Gear).....340Kg / 750 lbs  
 Maximum Bed Load..... 114 Kg / 250 lbs  
 Bed Capacity..... 0.127 cu m / 4.5 cu ft  
 Under-Seat Storage Capacity..... 0.09 cu m / 3.25 cu ft  
 Maximum Towing Capacity (Rolling Load) .....227 Kg / 500 lbs  
 Climbing Angle.....15-20°  
 Fuel tank.....10 L / 2.64 Gal  
 Engine Oil..... 30 oz  
 Battery.....12V 9Ah  
 Head Light ..... 12V 25W each  
 Top Speed (Speed Limited)..... 45 – 48 kph / 28 – 30mph

### CHASSIS

Brakes (Front and Rear).....Hydraulic disc  
 Tires – Front / Rear.....20 x 8.0-8 @ 15psi / 22 x 11-10 @ 15psi  
 Suspension-Front.....Dual A-arm with 1.8” (45mm) of travel  
 Suspension-Rear ..... Spring over shock with 2.0”(60mm) of travel

### WEIGHT

Dry Weight..... 279Kg / 615 lbs

### WARRANTY

Most Components / Frame / Engine ..... 1 year  
 Battery ..... 30 days



### 200 Series Light Utility Vehicle Wiring Diagram

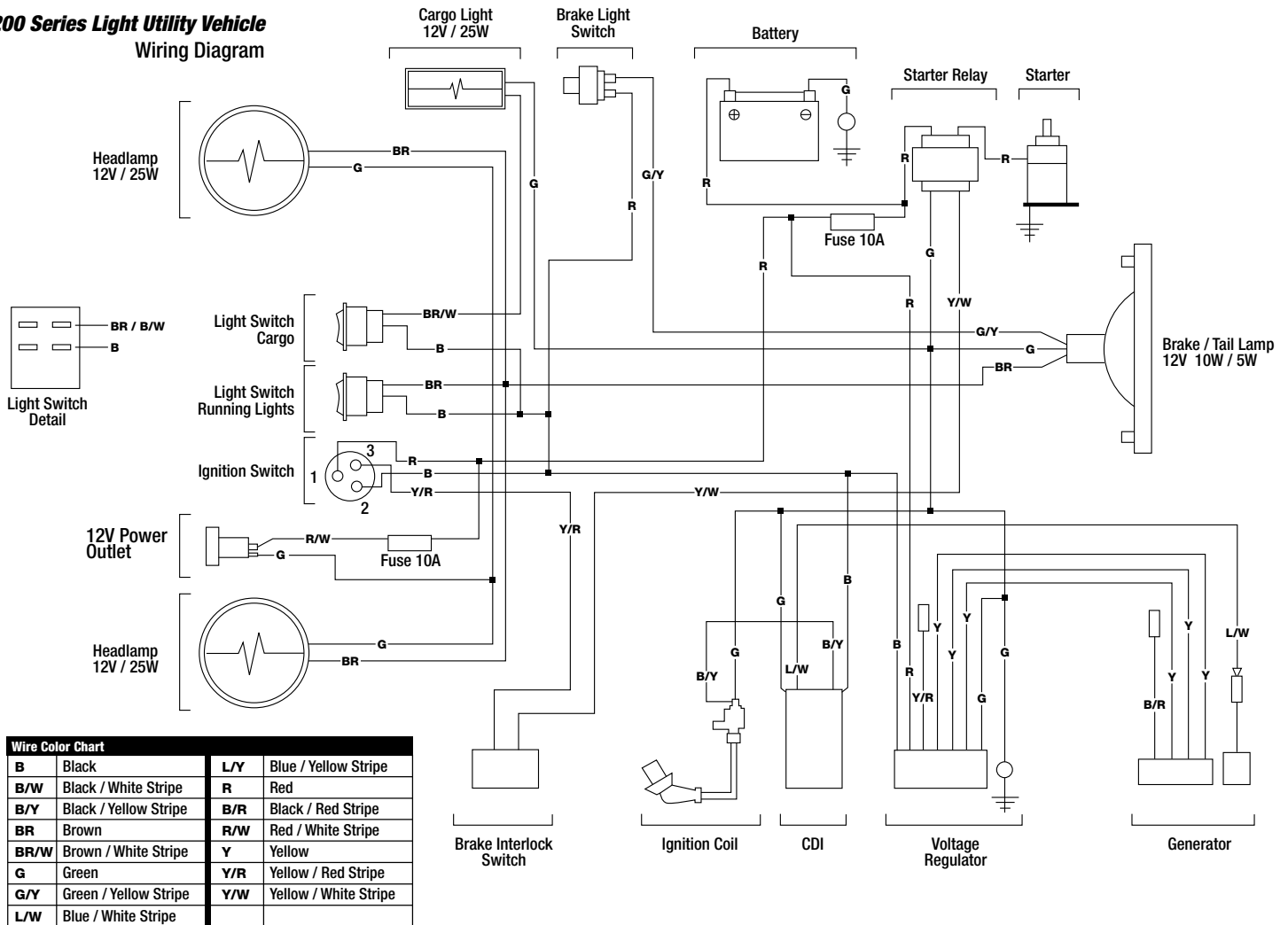

Revised May 2015

200 series utility vehicle

# PARTS & ACCESSORIES

available from American SportWorks

American SportWorks carries a full line of parts & accessories for the 200 series utility vehicle. Your vehicle is the latest edition of the 200 Series. Please check with Customer Service to make sure that any desired accessories will work with the new 200. Parts can be obtained by locating the needed part number by referring to the Illustrated Parts List (IPL) for your unit at [amsportworks.com](http://amsportworks.com) then you can call 800-643-7332 or go online to our webstore to place an order.



**Hard Tops & Windshields**



**Plow Blades & Tool Holders**



**Hour Meters**



**Wheel Covers**



**Brake Parts**



**Belts**



**Cables**

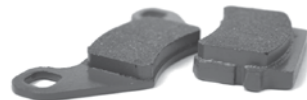

**Spark Plugs**



**Oil / Fuel / Air Filters**

# 200 SERIES PRE RIDE INSPECTION

ITEM	INSPECTION PROCEDURE	ACTION
<b>Engine Oil Level</b>	Add oil if required. Check for leaks. Tighten filler cap securely.	Refer to operator's or engine manual.
<b>Fuel Level</b>	Add fuel if necessary. DO NOT overfill. DO NOT mix oil with gas. Replace cap tightly.	Refer to operator's or engine manual. DO NOT refuel a hot engine. Allow engine to cool before adding fuel.
<b>Warning Decals</b>	Make sure all warning decals are legible and securely attached.	Replace as necessary.
<b>Tires</b> (15 PSI recommended)	Tread must have a minimum height of 1/8" at center of tire. Prior to operating vehicle, check and adjust tire pressure as indicated on the sidewall of each tire, or in the vehicle manual. A tire pressure gauge is required to obtain accurate readings.	Replace tires if tread height is less than 1/8" at center of tire. Add or remove air as necessary to meet requirements indicated on sidewall of each tire or in the specifications section of the vehicle manual.
<b>Drive Chain</b>	Check condition and tension	Lubricate, adjust tension as necessary.
<b>Throttle</b>	Check for smooth operation. Ensure throttle 'snaps' back to idle. Check for frayed or loose cable. Check for mud, debris, and ice in throttle mechanism Check idle adjustment	Replace damaged cable. Clean out any mud and debris. If ice is present, move vehicle to a warm place and allow the ice to melt and water to dry. Adjust as necessary
<b>Fasteners</b>	Check wheels to see that all axle nuts are tightened securely. Check for missing fasteners. Check that all other fasteners are secure.	Tighten fasteners as necessary. Replace fasteners as necessary.
<b>Brush Bars</b>	Make sure all brush bars are in place and securely attached.	Replace damaged bars or fasteners and tighten as necessary.
<b>Steering</b>	Make sure steering turns freely. Check for proper 'toe-in' of wheels.	Lubricate and adjust as necessary.
<b>Frame / Chassis</b>	Check for bent or otherwise damaged frame and/or other chassis components.	Replace as necessary.
<b>Guards</b>	Check all guards covering moving parts.	Tighten fasteners on loose guards. Replace worn or damaged guards.
<b>Lights</b> (if applicable)	Check for proper operation	See OPERATION section of the Owners Manual / Parts Guide
<b>Suspension and Ball Joints</b>	Check for ball looseness.	See SERVICE section of the Owners Manual / Parts Guide.
<b>Brakes</b> (Service & Park)	Ensure brakes function properly.	Adjust / replace as necessary.
<b>Battery</b>	Make sure both terminals securely fastened. Make sure that no corrosion is present. Make sure that the battery is secure in holder.	Tighten as necessary. Clean as necessary. Secure with current or new parts as necessary.
<b>Suspension</b>	Make sure that all suspension joints are moving freely. Check for excessive movement in ball joints.	Lubricate, adjust, or replace as necessary.
<b>Seat Belts</b>	Make sure that the seat belt extends, retracts, and locks. Make sure that all latches are functional.	Replace damaged seat belts.
<b>Bed &amp; Seat Latches</b>	Make sure that seat and bed latches are secured.	Repair, Latch or Adjust as necessary.
<b>Cooling Fan</b>	Make sure that fan is clear of debris.	Clean.
<b>Ignition Switch</b>	Make sure that the engine shuts off when key is turned to the "OFF" position.	Repair/Replace as necessary.



200 SERIES LUTV OWNERS MANUAL

## ORDERING PARTS

1) Seek Part(s) from your models illustrated diagram, cross over REF# to PART#

2) Type PART# into sites [Search Box] at [GoKartsRus.com](http://GoKartsRus.com) TIP! - RIGHT CLICK LINK, SELECT OPEN IN NEW TAB

3) Add all needed parts to Shopping Cart | Complete "Checkout" | ✓ Done!

If a part does not come up in a Site Search, please [Contact US](#) (include part# in email)

FAST & EASY!
LOWEST PRICES!