

CW11 / TW11 / TW11R

WITH 340cc HONDA ENGINE

ORDERING PARTS

FAST & EASY!

- 1) Seek Part(s) from your models illustrated diagram, cross over REF# to PART#
- 2) Type PART# into sites [Search Box] at GoKartsRus.com TIP! - RIGHT CLICK LINK, SELECT OPEN IN NEW TAB
- 3) Add all needed parts to Shopping Cart | Complete "Checkout" | ✓ Done!

If a part does not come up in a Site Search, please [Contact Us](#) (include part# in email)

LOWEST PRICES!



340CC 2 WHEEL DRIVE UTILITY VEHICLE

ILLUSTRATED PARTS LIST



NOTE:

Some part numbers vary by serial number.
The serial number is located on a brass tag
beneath the dump bed on the driver side.

BODY

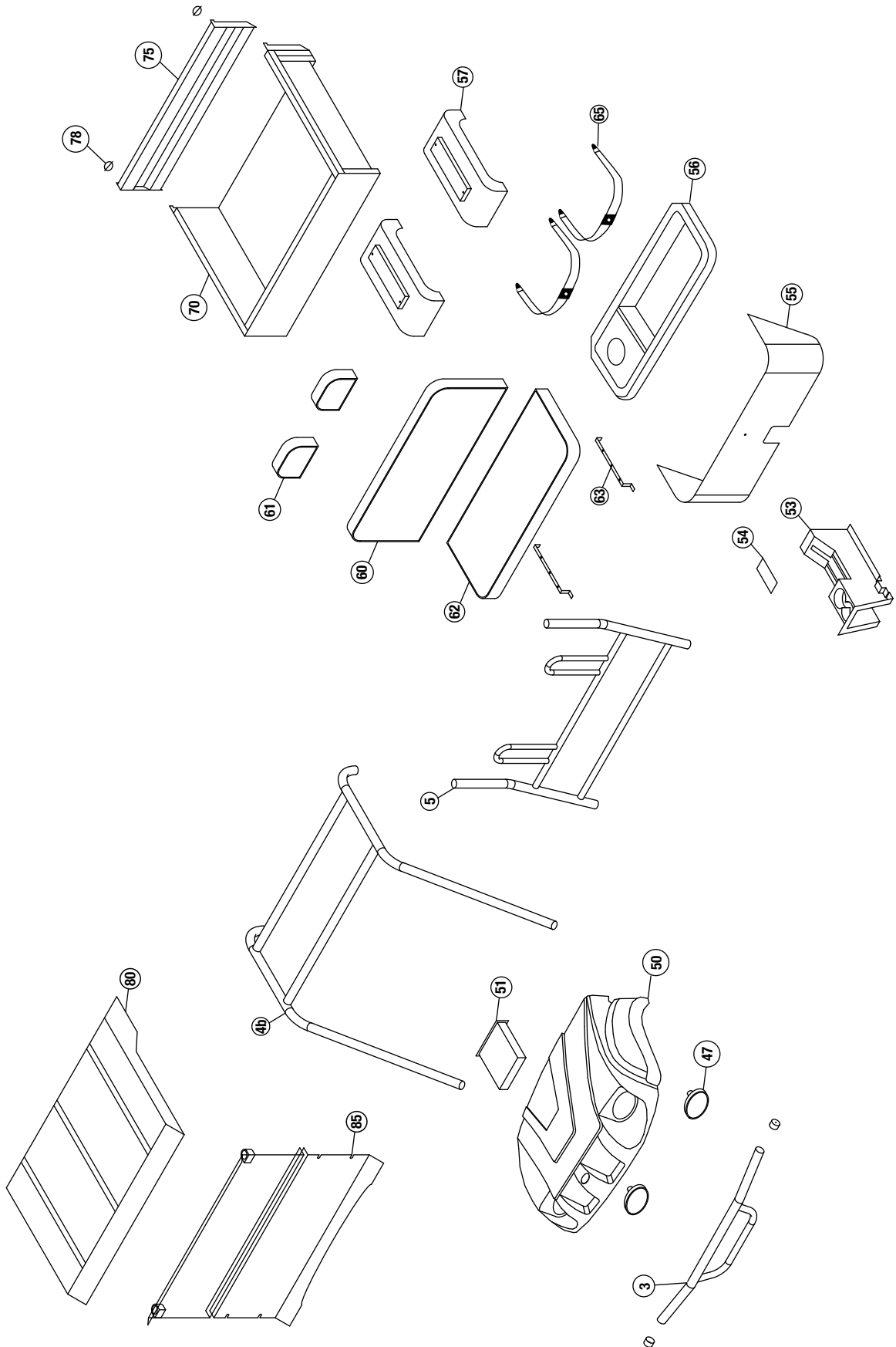

FRAME

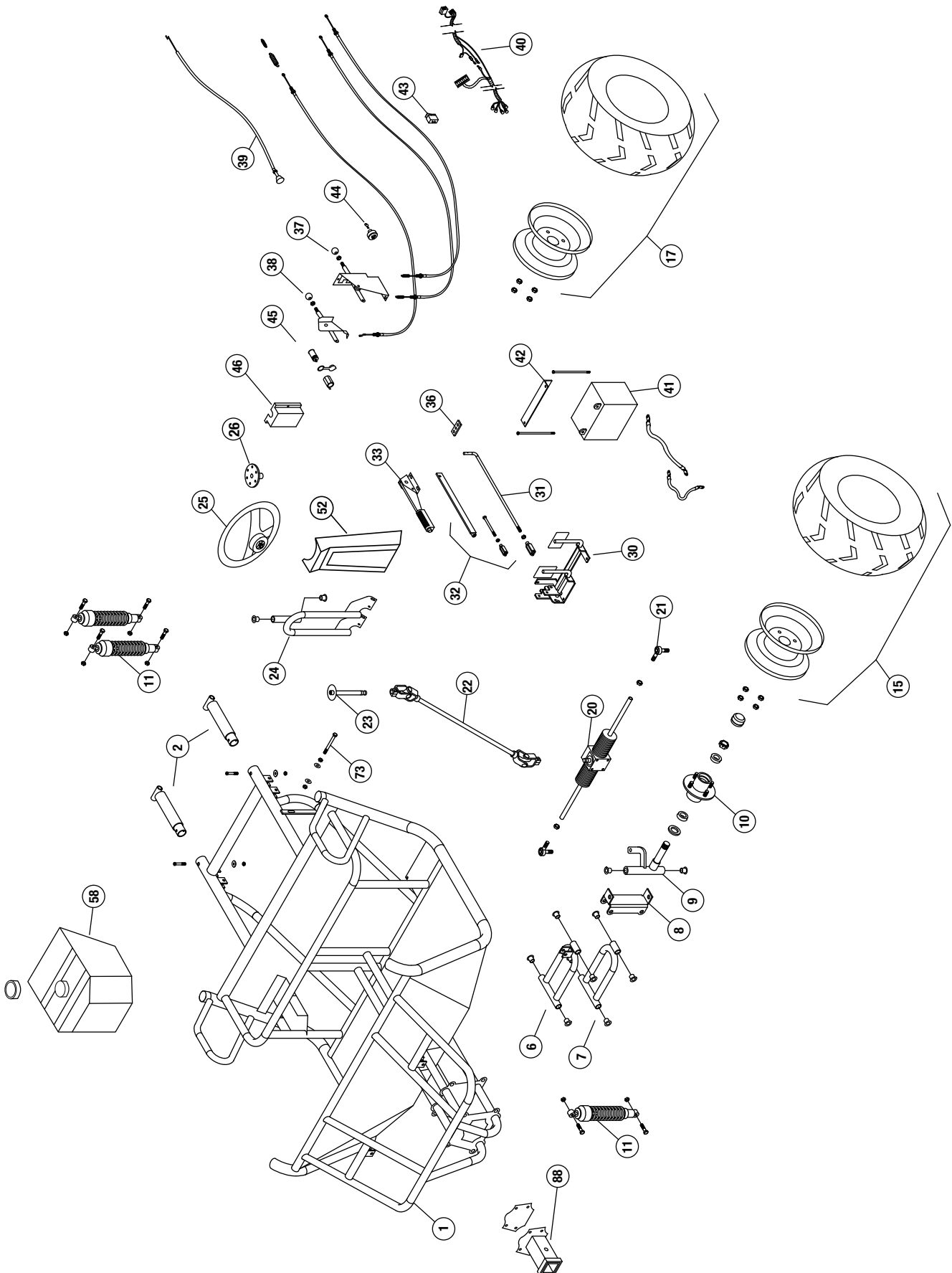

For complete transaxle breakdown refer to the DANA manuals in the SERVICE MANUALS / ENGINE MANUALS / USER GUIDES section of the online manuals at amsportworks.com

DRIVETRAIN

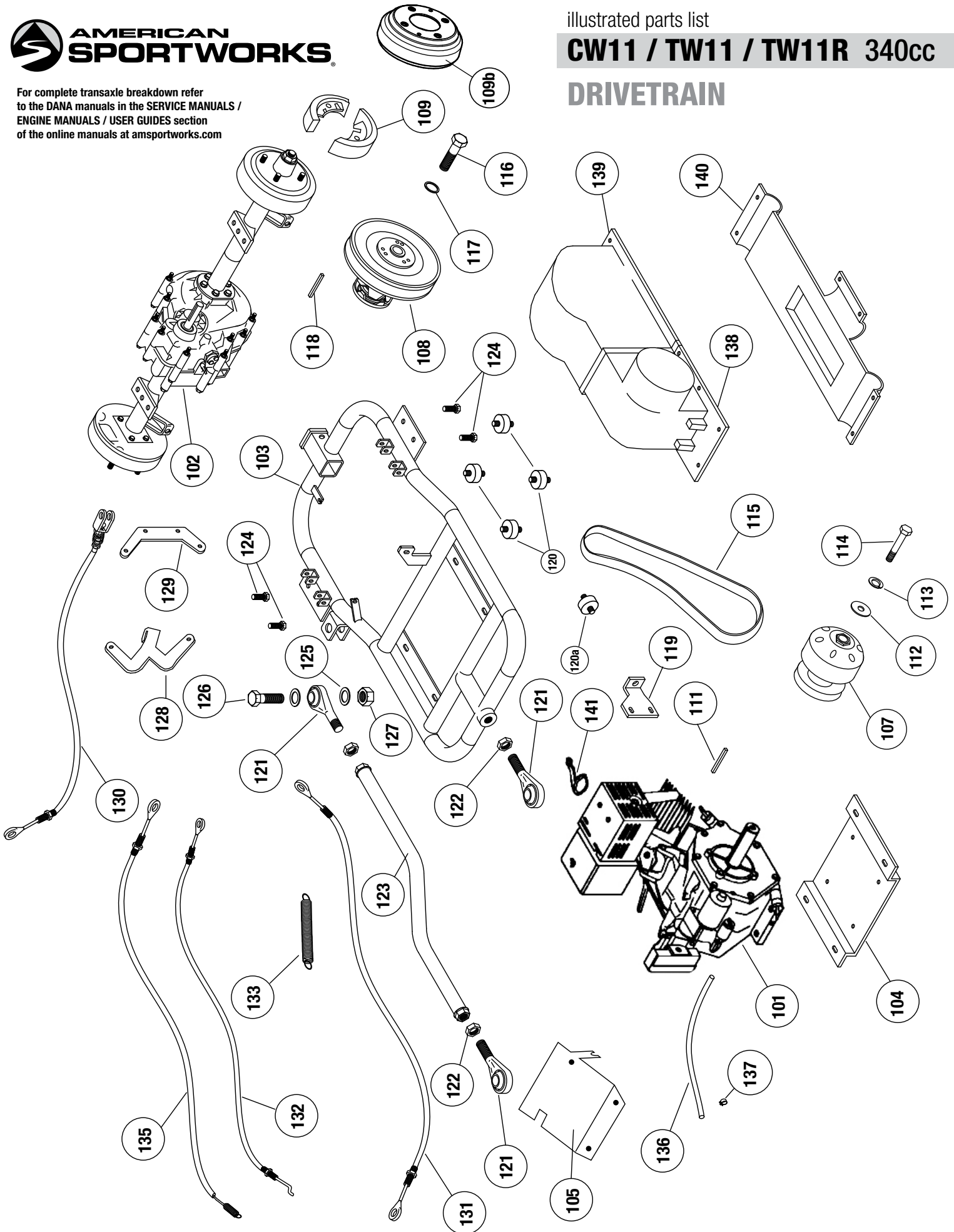

NOTE: parts denoted as left or right hand are from driver's point of view.

REFERENCE NUMBER	PART NUMBER	PART DESCRIPTION	QUANTITY REQUIRED
1	-	Frame, CW11	1
2	2-45401	Rear frame stub, CW - black	2
-	2-50168	5/16 x 2-1/4" USS Socket Head bolt	2
-	2-50007	nut, 5/16 nylock	2
-	2-50702	bent washer 5/16	2
3	2-45413	bumper, CW - black	1
-	2-45432	Bumper, Trail Wagon – Black	1
-	2-50167	bolt, 5/16 x 2	4
-	2-50007	nut, 5/16 nylock	4
-	2-50702	bent washer 5/16	4
-	2-70210	Vinyl Caps 1 3/4 x 1 1/2	2
4	2-45412	Brush Guard roof, CW – black	1
-	2-50168	5/16 x 2-1/4" USS Socket Head bolt	4
-	2-50007	nut, 5/16 nylock	4
-	2-50702	bent washer 5/16	4
5	2-45411	brshgrd seat back, CW – black	1
-	2-50168	5/16 x 2-1/4" USS Socket Head bolt	2
-	2-50007	nut, 5/16 nylock	2
-	2-50702	bent washer 5/16	2
6	2-45404	A-arm upper, CW – black (left or right)	2
-	2-51102	suspension bushings	4 ea
-	2-50097	bolt, 3/8 x 8.5"	1 ea
-	2-50212	Bolt, 3/8 x 3.25 bolt	2 ea
-	2-10048	DOM 3/8" ID x 2.2"	2
-	2-50010	Nylock Nut 3/8"-16	5 ea
-	2-50225	Bolt, 3/8" x 8"	2 ea
-	2-42114	Spacer, 3/8" ID x 6.93"	2 ea
7	2-45405	A-arm Lower, CW – black (left or right)	2
-	2-51102	suspension bushings	4 ea
-	2-50097	bolt, 3/8 x 8.5"	1 ea
-	2-50221	Bolt, 3/8 x 3.25 bolt	1 ea
-	2-10048	DOM 3/8" ID x 2.2"	2 ea
-	2-50010	Nylock Nut 3/8"-16	5 ea
-	2-50225	Bolt, 3/8" x 8"	2 ea
-	2-42114	Spacer, 3/8" ID x 6.93"	2 ea
8	2-45408	spindle mount, CW – black	2
9a	2-45406	Spindle, cw left – black	1
9b	2-45407	Spindle, cw right – black	1
-	2-10049	DOM 3/8" ID x 7.5"	2
-	2-51102	suspension bushings	2 ea
10	2-30604	Hub, 4 bolt high speed 1" Complete with Bearings & Seals	2
-	2-25018	Wheel stud, 1/2 -20 X 1 5/8"	
-	2-11205	bearing, 1" tapered	
-	2-30620	seal	
-	2-30622	castle nut, 1"	
-	2-30621	cotter pin	
-	2-30623	Metal Dust Cap (Front Only)	2
-	2-70209	Rubber Dust Cap (Rear Only)	2
-	2-50060	Lug nuts, 1/2"	
11	2-70301	Shock, Heavy duty, Black/Yellow (Before Serial # 52767)	6

NOTE: parts denoted as left or right hand are from driver's point of view.

REFERENCE NUMBER	PART NUMBER	PART DESCRIPTION	QUANTITY REQUIRED
-	2-70302	Shock, Heavy duty, Black (After Serial #52767)	
-	2-50400	Bolt, 10 mm x 40mm	12
-	2-50065	Nut, 10mm nylock	12
15L	2-30122	Rim/Tire Assembly, UTV 22/9-10" Left	1
15R	2-30123	Rim/Tire Assembly, UTV 22/9-10" Right	1
-	2-30480	Wheel rim, 10" x 6"	
-	2-30195	Tire, Pathfinder 22/9-10"	
17L	2-30124	Rim/Tire Assembly, UTV 22/11-10" Left	1
17R	2-30125	Rim/Tire Assembly, UTV 22/11-10" Right	1
-	2-30480	Wheel rim, 10" x 6"	
-	2-30194	Tire, Pathfinder 22/11-10"	
20	2-10521	Rack & pinion with rod ends	1
-	2-10593	Rack & Pinion Boots	2
-	N/A	Rack & Pinion Rod – Not available sold as assembly only (2-10521)	
-	2-50171	Bolt, 5/16 x 3 3/4" USS	4
-	2-50005	Nut, 5/16 keps	4
-	2-50063	Nut, 1/2" SAE nylock	2
21	2-10524	Rod end (use before serial #27213)	2
-	2-10589	Rod end (use after serial #27214)	2
-	2-50078	Nut, 1/2" SAE jam	2
22	2-10522	Steering Shaft with U-joints	1
-	2-50402	Bolt, 10mm x 30mm	1
-	2-50066	Nut, 10mm Tri Lock Jam	1
-	2-50403	Bolt, 8mm x 30mm	1
-	2-50780	Lock washer, 8mm	1
23	2-18170	Steering Hub Shaft	1
-	2-50708	Washer, 0.642 in. ID x 1 in. OD - wave	1
-	2-51102	Bushing, oil impregnated - Bronze 0.636 in	2
24	2-45400	Steering support, CW – black	1
-	2-51102	suspension bushings	2 ea
-	2-50152	bolt, 5/16 x 1	4
-	2-50005	Nut, 5/16 keps	4
25	14845	Steering Wheel (used for serial number 48598 and above)	1
-	14846	Center cap (used for serial number 48598 and above)	1
-	2-10508	Center cap (used for serial number 48598 and below)	1
-	2-10509	Steering Wheel (used for serial number 48598 and below)	1
26	2-18169	Steering Hub Washer	1
-	2-50636	bolt, 1/4 x 3/4 SS Socket Head	6
-	2-50001	nut, 1/4 nylock	6
-	2-50098	Tapered Bolt	1
30	2-42106	Pivot Pedal Asm, Black	1
-	2-70261	Pedal cover, rubber	2
-	2-50152	bolt, 5/16 x 1	6
-	2-50081	bolt, 1/4 x 1 3/4"	1
-	2-50159	bolt, 5/16 x 1 1/2	1
-	2-50005	Nut, 5/16 keps	8
-	2-50701	Washer, 5/16 flat	2
31	2-11181	Brake Rod, with clevis	1
-	2-50215	bolt, 3/8 x 1 1/4	1
-	2-50010	nut, 3/8" nylock	1

NOTE: parts denoted as left or right hand are from driver's point of view.

REFERENCE NUMBER	PART NUMBER	PART DESCRIPTION	QUANTITY REQUIRED
-	2-50801	cotter pin 1/8" x 1	1
32	2-45417	parking brake bar, CW – black	1
-	2-50806	Clevis, 5/16 rod end	1
-	2-50170	Bolt, 5/16"-24 X 4" SAE	1
-	2-50077	Nut, 5/16" Hex SAE	1
-	2-50087	bolt, 1/4" x 1	1
-	2-50001	nut, 1/4" nylock	1
33	2-11127	Parking Brake	1
-	2-50086	Bolt, 1/4 x 1 1/4	1
-	2-50001	nut, 1/4" nylock	1
-	2-50163	bolt, 5/16 x 3/4" NC	4
-	2-50005	Nut, 5/16 keps	4
-	2-50701	Washer, 5/16 flat	4
36	2-45415	Brake equalizer, CW (2 1/2") – black	1
-	2-50215	bolt, 3/8 x 1 1/4	2
-	2-50010	nut, 3/8" ny-lock	2
37	2-45522	Shifter control assembly, black (used on units built after 2-1-05)	1
-	2-11093	Knob	1
-	2-11082	Cable, shifter (used on units built after 2-1-05)	2
-	2-11080	Shifter Cable and Shifter Control (used on units built before 2-1-05)	1
-	2-50053	nut, #10-24 Keps nut	2
-	2-50616	screw, #10-24 X 3/4" Pan Head Phillips	2
-	2-50770	Washer, #10 flat	2
38	2-45522	Differential Control assembly with cable and knob	1
-	2-11092	Knob	
-	2-11094	cable, diff lock	
-	2-50053	nut, #10-24 Keps nut	2
-	2-50616	screw, #10-24 X 3/4" Pan Head phillips	2
-	2-50770	Washer, #10 flat	2
39	2-11053	Choke Cable	1
40	2-70012	Wire Harness	1
41	2-70000	Battery, U1L-HDJ7-UTV - 360CCA	1
-	2-70002	Battery Cable, Red – 19"	1
-	2-70010	Battery Cable, Black (27")	1
-	2-70009	Battery Terminal Cover	2
-	2-50087	bolt, 1/4" x 1	2
-	2-50000	nut, 1/4" keps	2
42	2-45414	Battery strap, CW (8 3/4") – black	1
-	2-50083	bolt, 1/4 x 7 1/2	2
-	2-50002	nut, 1/4" wing	2
43	2-70066	Headlight Switch	1
44	2-70052	Key Switch (keys not included) USED ON VEHICLES MANUFACTURED BEFORE SERIAL NUMBER 58843	1
-	2-70060	Key USED ON VEHICLES MANUFACTURED BEFORE SERIAL NUMBER 58843	1
45	2-70080	Accessory Plug	1
-	2-70081	Accessory Plug cap	1
46	2-18500	Terminal Block Cover – plastic	1
-	2-50625	screw, #10-24 X 1" Pan Head Phillips	2
-	2-50053	nut, #10-24 Keps nut	2
47	SEE LAST PAGE FOR HEADLIGHT INFORMATION		
-	2-70055	Switch Headlights	1

NOTE: parts denoted as left or right hand are from driver's point of view.

REFERENCE NUMBER	PART NUMBER	PART DESCRIPTION	QUANTITY REQUIRED
50	2-18311	Hood, plastic Green	1
-	2-18302	Hood, plastic Red	
-	2-18350	Hood, plastic Camo	
-	2-50620	¼" X 1 ¼" Pan Head Phillips Machine screw	2
-	2-50621	¼" X 2" Pan Head Phillips Machine screw	2
-	2-50717	¼" SAE Flat washer	8
-	2-50001	nut, ¼" nylock	4
-	2-50846	Clamp-Tube-vinyl coated 1-1/4"	2
51	2-18309	Glove Box	1
-	2-50624	Screw, #10 x ¾ hex – black	5
52	2-18308	Steering Cover	1
-	2-18317	Steering Cover Bottom	1
-	2-50624	Screw, #10 x ¾ hex – black	1
53	2-18306	Center Console	1
-	2-50624	Screw, #10 x ¾ hex – black	14
54	2-18316	Access Cover, Center Console	1
-	2-50624	Screw, #10 x ¾ hex – black	4
55	2-18305	Plastic, Seat Bottom wrap	1
-	2-50624	Screw, #10 x ¾ hex – black	5
56	2-18355	Under seat storage box	1
57	2-18303	Rear Fender Universal	2
-	2-50001	nut, ¼ nylock	4
-	2-50091	Bolt, ¼"-20 X ¾" Hex Head	4
-	2-50717	¼" SAE Flat washer	4
-	2-70150	Reflectors	2
58	2-55068	Fuel Tank Extended Fill Neck	1
-	2-65503	UTV, Fuel Line 3/16" black	1
-	2-55063	Elbow Fuel Inlet w/ #200 Mesh Screen	1
-	2-55062	Fuel Fitting Grommet	1
-	2-55061	Cap Fuel Tank	1
-	2-50163	bolt, 5/16 x 3/4" NC	3
-	2-50706	Washer, 5/16 fender	3
-	2-50703	Washer, 5/16 lock	3
60	2-10771	Seat back – BLACK & GREY – 43 ½ x 17 ½	1
60	2-10754	Seat back – BLACK – 43 ½ x 17 ½	1
-	2-50619	#14 X 1-3/4" Pan head-Tapping screw	6
61	2-10803	Headrest – UTV 9 x 6 ½	2
-	2-50085	bolt, ¼ x 1 ½"	4
61	2-10773	Headrest – BLACK & GREY – 9 x 6 ½	2
61	2-10803	Headrest – BLACK – 9 x 6 ½	2
62	2-10772	Seat bottom – BLACK & GREY – 43 ½ x 17 ½	1
62	2-10755	Seat bottom – BLACK – 43 ½ x 17 ½	1
63	2-45416	seat bar, CW (17 ½") – black	2
-	2-50609	#14 x ¾ Pan Head Screw	6
65	2-10705	Seat Belt, 2pt	2
-	2-50025	7/16 Nylock	4
70a	2-45426	Cargo Bed, Green	1
-	2-45420	Cargo Bed, Red	1
-	2-45424	Cargo Bed, Black	1
-	2-18352	Camo Bed Panel Left	1

NOTE: parts denoted as left or right hand are from driver's point of view.

REFERENCE NUMBER	PART NUMBER	PART DESCRIPTION	QUANTITY REQUIRED
-	2-18353	Camo Bed Panel Right	1
-	2-18354	Camo Bed Panel Tail Gate	1
70b	2-18356	Dump Bed UTV Plastic	1
-	2-50255	5/8 x 4" bolt Zinc plate	2
-	2-50015	5/8 nylock	2
73	2-50208	Bed latch bolt, 3/8 x 2 1/2"	1
-	2-50013	nut, 3/8 keps	2
-	2-50740	washer, 3/8 flat	2
75a	2-45427	Tail gate, green	1
-	2-45421	Tail gate, Red	1
-	2-45425	Tail gate, Black	1
75b	2-18357	Dump Bed Tailgate UTV Plastic	1
-	2-50152	bolt, 5/16 x 1	2
-	2-50701	washer, 5/16 sae	4
-	2-50007	nut, 5/16 nylock	2
-	2-70230	rubber bump stops	4
-	2-18413	Bed Bumper 3/8" Rubber	2
78	2-50815	1/4" Lynch Pin - tailgate latch	2
80	2-18312	Roof, green	1
-	2-18301	Roof, Red	1
-	2-18351	Roof, Camo	1
-	2-18391	Roof, Top Vinyl Trim	1
-	2-18390	Roof, Hardware bolt kit	
-	2-50847	Clamp-Tube-vinyl coated 1-3/4"	4
-	2-50087	bolt, 1/4" x 1	4
-	2-50718	Washer, 1/4" rubber domed	4
-	2-50001	nut, 1/4" nylock	4
85	2-18400	Windshield - clear	
88	2-40723	Front receiver hitch kit	
101	2-20010	Engine, Honda 11hp	1
-	2-50202	3/8-16 x 1 3/4" Hex Hd Bolt	4
-	2-50740	3/8" Flat washer, USS	4
102	2-20833	Dana Transaxle	1
-	2-70057	Neutral Safety Switch	1
-	2-51500	Shims – Neutral Safety Switch	
103	2-45423	Swing arm, CW - Black	1
104	2-45430	Motor Plate, CW - Black	1
105	2-18023	Throttle Guard Laser	1
-	2-50086	1/4-20 x 1 1/4" Hex Hd Bolt	3
-	2-50082	1/4-20 x 2 1/4" Hex Hd Bolt	1
-	2-50000	1/4" Keps Nut	5
-	2-50715	1/4" Flatwasher, USS	8
107	2-20648	TC, Driver Comet 500 – used before Serial Number # 25658	1
-	2-20665	TC, Driver CVTECH – used after Serial Number # 25658	1
108	2-20649	TC, Driven Comet 500 – used before Serial Number # 25658	1
-	2-20666	TC, Driven CVTECH – used after Serial Number # 25658	1
109	16279	Brake Shoes - Rear UTV – Dana (kit includes 4 shoes to cover both rear wheels)	1
109b	2-11191	Brake Drum Replacement #012WA123	2
110	2-50745	1" I.D. Spacer Washer – Comet only (not used with CVTech pulley)	4
111	2-10190	3/16 x 1/4 x 1-1/2" Keystock (for use with CV Tech driver pulley)	1

NOTE: parts denoted as left or right hand are from driver's point of view.

REFERENCE NUMBER	PART NUMBER	PART DESCRIPTION	QUANTITY REQUIRED
112	2-50745	3/8" I.D. Fender Washer – Comet only (not used with CVTech pulley)	1
113	2-50741	3/8" Lock Washer – Comet only (not used with CVTech pulley)	1
114	2-50219	3/8x 3" Bolt Hex Hd NF – Comet only (not used with CVTech pulley)	1
115	2-20693	Belt, Comet 300668 - used before Serial Number # 25658	1
-	2-20694	Belt, CV TECH – used after Serial Number # 25658	1
116	2-50239	1/2 x 2" SAE	1
117	2-50722	1/2" Lock Washer	1
-	2-50721	1/2" Uss Flat Washer	1
118	2-10191	3/16 x 3/16 x 3-1/4" Keystock (for use with CV Tech driven pulley)	1
119	2-45431	Tension Mount Engine, CW - Black	1
-	2-50157	5/16x 3/4" Bolt Hex Hd NF	2
-	2-50703	5/16" Lock Washer	2
-	2-50704	5/16" Flatwasher	2
120	2-70251	Rubber Feet (Isolators)* SEE NOTE ON BACK PAGE	4
120a	2-70252	Rubber Feet (Isolator)* SEE NOTE ON BACK PAGE	1
-	2-50010	3/8 Nylock Nut	10
-	2-50740	3/8 Flatwasher USS	5
121	2-10583	Rod End Sphcl-UTV (4681-MPM-12)	3
122	2-50021	3/4 Jam nut SAE	3
123	2-42093	Panhard bar, CW - black	1
124	2-50206	bolt, 3/8 x 1	4
-	2-50010	3/8" Nylock Nut	4
-	2-50740	3/8" Flatwasher, USS	4
125	2-50730	3/4" Spacer Washer	6
126	2-50280	3/4 x 2.5 SAE bolt	3
127	2-50020	3/4 SAE nylock	3
128	2-18012	shifter lever, CW - black	1
-	2-50084	1/4-20 x 3/4" Hex Hd Bolt	1
-	2-50000	1/4" Keps Nut	2
129	2-18011	shifter cable mount, CW - black - used after Serial Number #15245	1
-	2-50084	1/4-20 x 3/4" Hex Hd Bolt	1
-	2-50000	1/4" Keps Nut	1
-	2-50715	1/4" Flatwasher, USS	2
130	2-11103	Brake Cables	2
-	2-50150	5/16-18 x 1" Hex Hd Bolt	2
-	2-50007	5/16" Nylock Nut	2
131	2-11010	Throttle Cable, UTV	1
-	2-50087	1/4-20 x 1" Hex Hd Bolt	1
-	2-50000	1/4" Keps Nut	2
-	2-11804	Spring #80704 Black painted	1
132	2-11084	Differential Cable All 2WD models before serial #22187	1
-	2-50087	1/4-20 x 1" Hex Hd Bolt	1
-	2-50000	1/4" Keps Nut	2
-	2-50159	5/16-18 x 1 1/2" Hex Hd Bolt	1
-	2-50005	5/16" Keps Nut	2
132	2-45522	Differential Control Assembly w/ cable all models after serial # 22187	1
-	2-11083	Knob	1
-	2-11091	Differential Control Cable Only used on all models after serial # 22187	1
-	2-50053	nut, #10-24 Keps nut	2
-	2-50616	screw, #10-24 X 3/4" Pan Head phillips	2

NOTE: parts denoted as left or right hand are from driver's point of view.

REFERENCE NUMBER	PART NUMBER	PART DESCRIPTION	QUANTITY REQUIRED
-	2-50770	Washer, #10 flat	2
-	2-50087	1/4-20 x 1" Hex Hd Bolt	1
-	2-50000	1/4" Keps Nut	2
-	2-50159	5/16-18 x 1 1/2" Hex Hd Bolt	1
-	2-50005	5/16" Keps Nut	2
133	2-11804	Spring #80704 Black painted	1
135	2-11080	Shifter Cable and Shifter Control - used before Serial Number #15244	1
-	2-11082	Cable, shifter - used after Serial Number #15245	2
136	2-65500	fuel hose 3/16" dia - 24"	1
137	2-50849	hose clamps - small	3
138	2-18313	Belt Guard Plastic UTV - Front	1
139	2-18314	Belt Guard Plastic UTV - Rear	1
140	2-18315	Belt Guard Plastic UTV - Bottom	1
-	2-50624	#10 x 3/4" Blunt Point Black	7
-	2-50050	#10 Speed Nut - for Plastic	7
-	2-50770	#10 Flat washer	7
141	2-20011	Choke Bracket Honda Engine	1

* On single cylinder models, quantity 5 of 2-70250 was replaced by quantity 4 of 2-70251 and 1 of 2-70252 on 6/1/2012. The 4 of the 2-70251 go under the engine and the 1 of the 2-70252 goes in the vertical mount. We do not recommend replacing only one bushing and that all four bushings should be replaced together.

HEADLIGHT REPLACEMENT BULBS AND ASSEMBLIES FOR ASW UTILITY VEHICLES

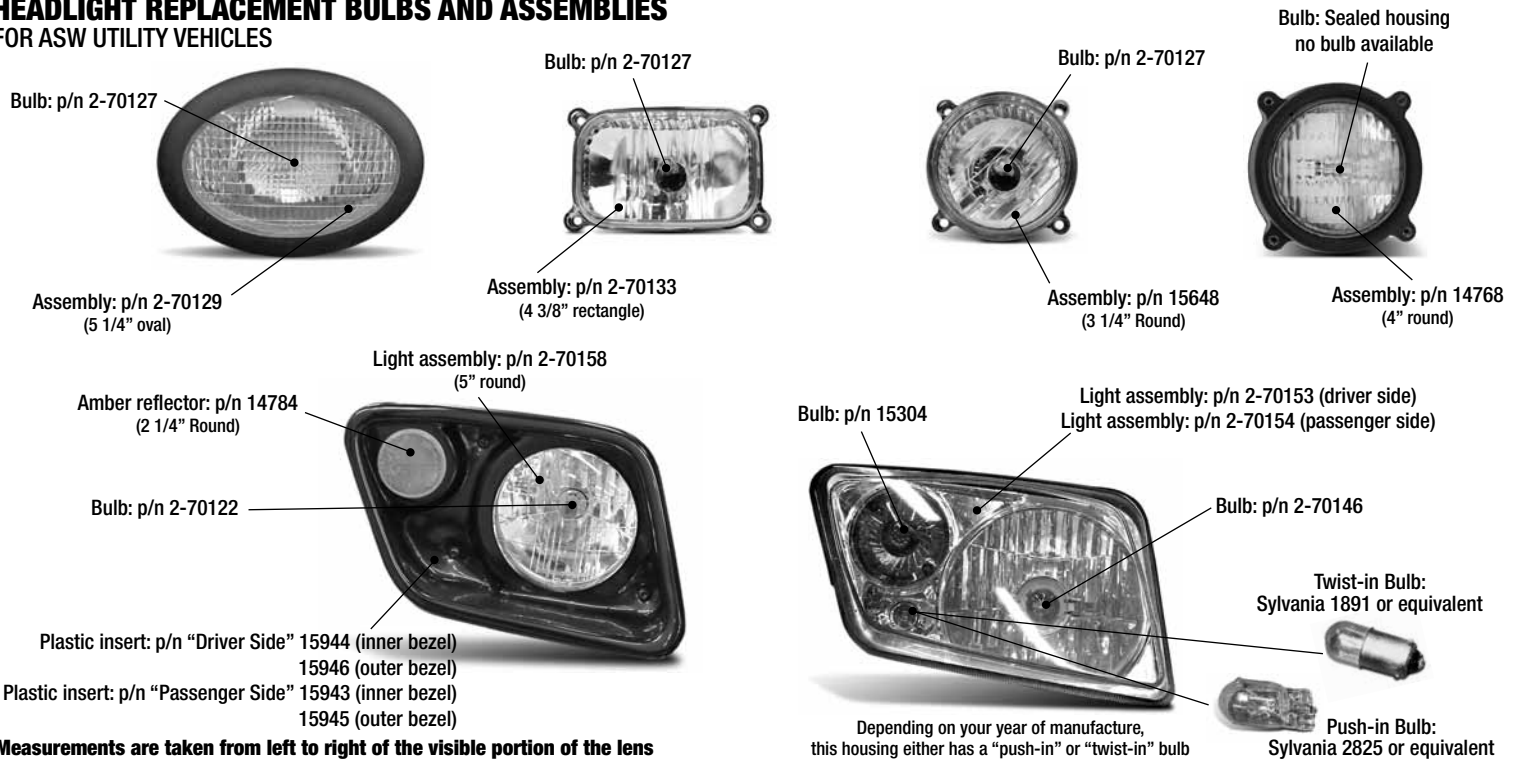

Measurements are taken from left to right of the visible portion of the lens

ORDERING PARTS

FAST & EASY!

- 1) Seek Part(s) from your models illustrated diagram, cross over REF# to PART#
- 2) Type PART# into sites [Search Box] at GoKartsRus.com TIP! - RIGHT CLICK LINK, SELECT OPEN IN NEW TAB
- 3) Add all needed parts to Shopping Cart | Complete "Checkout" | Done!

If a part does not come up in a Site Search, please [Contact Us](#) (include part# in email)

LOWEST PRICES!