

LM400

WITH 390cc HONDA ENGINE

ORDERING PARTS

FAST & EASY!

- 1) Seek Part(s) from your models illustrated diagram, cross over REF# to PART#
- 2) Type PART# into sites [Search Box] at GoKartsRus.com TIP! - RIGHT CLICK LINK, SELECT OPEN IN NEW TAB
- 3) Add all needed parts to Shopping Cart | Complete "Checkout" | ✓ Done!

If a part does not come up in a Site Search, please [Contact Us](#) (include part# in email)

LOWEST PRICES!



390CC 2 WHEEL DRIVE UTILITY VEHICLE

ILLUSTRATED PARTS LIST



NOTE:

Some part numbers vary by serial number.
The serial number is located on a brass tag
beneath the dump bed on the driver side.

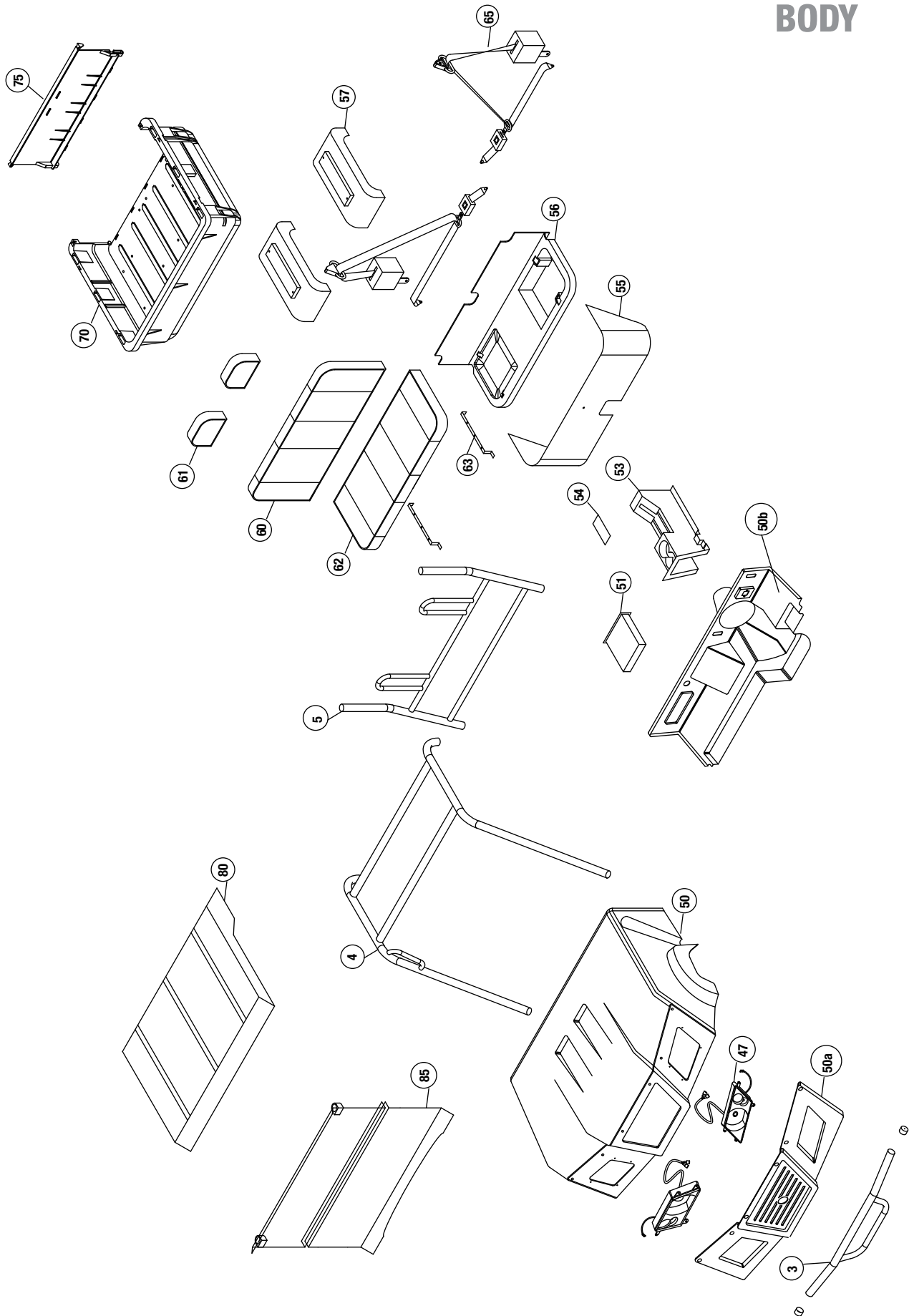

NOTE: parts denoted as left or right hand are from driver's point of view.

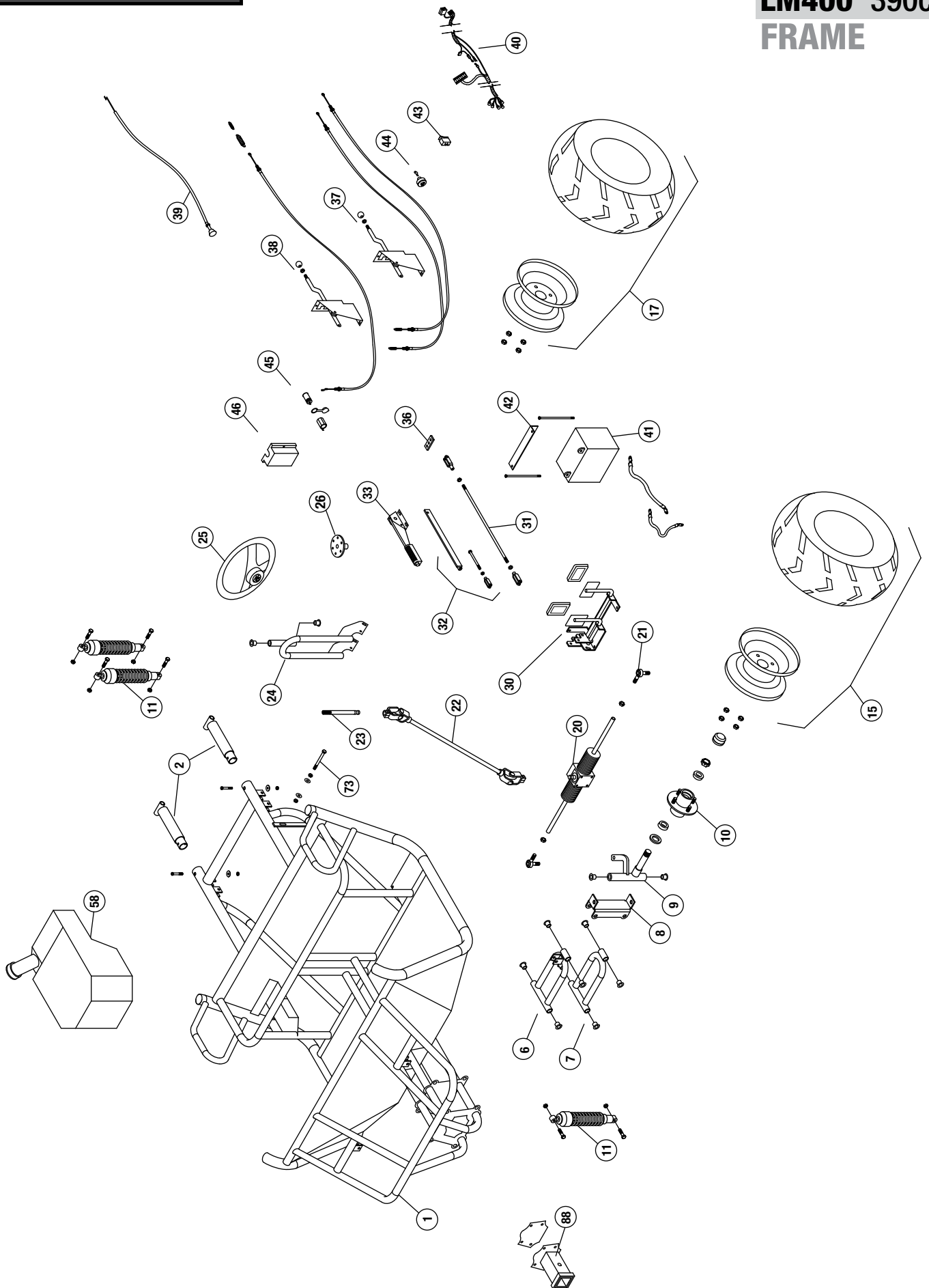

NOTE: parts denoted as left or right hand are from driver's point of view.

For complete transaxle breakdown refer to the DANA manuals in the SERVICE MANUALS / ENGINE MANUALS / USER GUIDES section of the online manuals at amsportworks.com

illustrated parts list
LM400 390cc
DRIVETRAIN

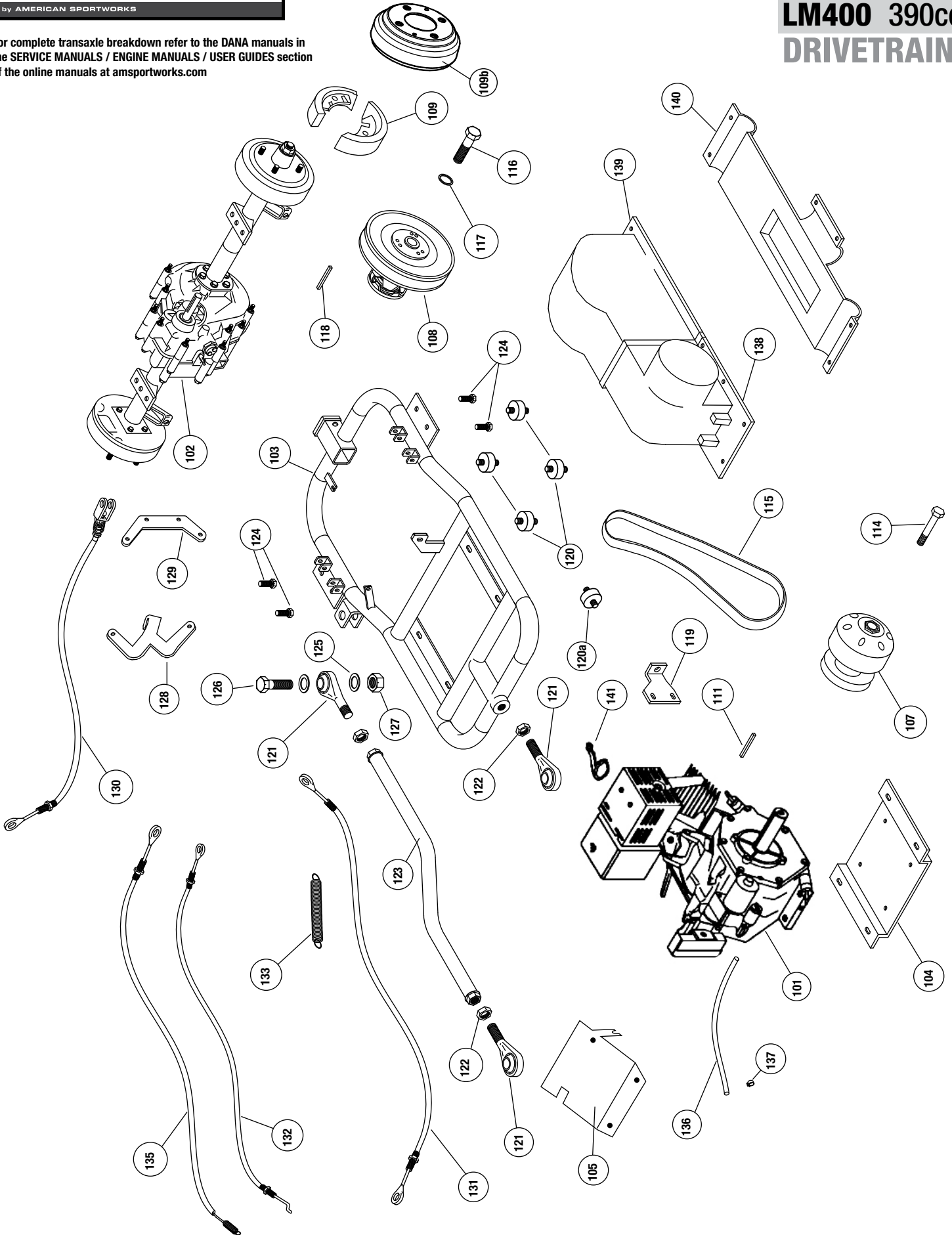

NOTE: parts denoted as left or right hand are from driver's point of view.

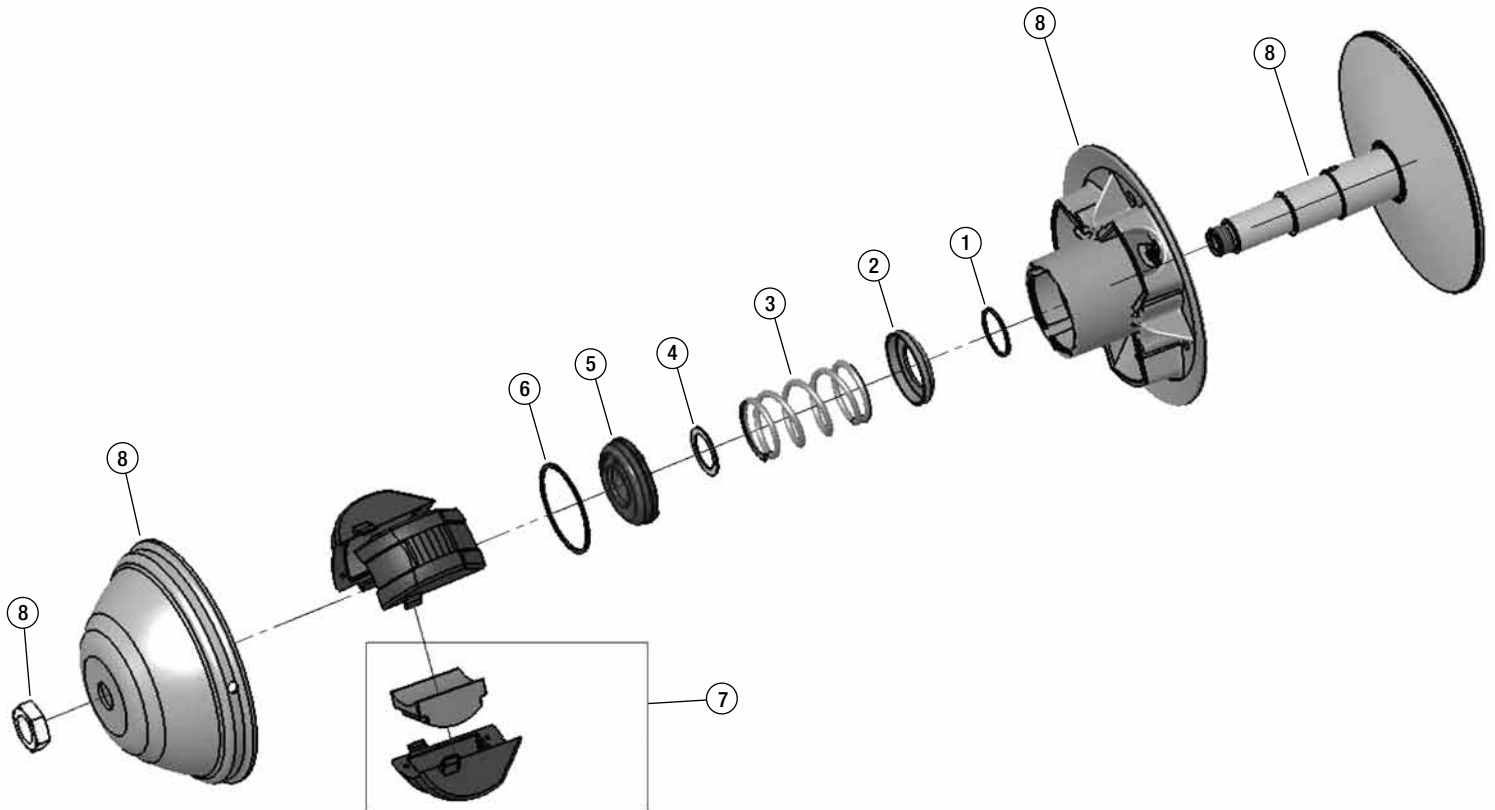

ENTIRE ASSEMBLY (2-20665)

Ref#	Part#	Description	Qty
1	16374	WASHER	1
2	16375	SPRING GUIDE	1
3	16376	SPRING	1
4	16377	SHIM	1
5	16378	EXTERNAL BUSHING	1
6	16379	INTERNAL SNAP RING	1
7	16389	CENTRIFUGAL MASS	3
8	2-20665	THIS PART IS ONLY AVAILABLE WITH THE ENTIRE ASSEMBLY	

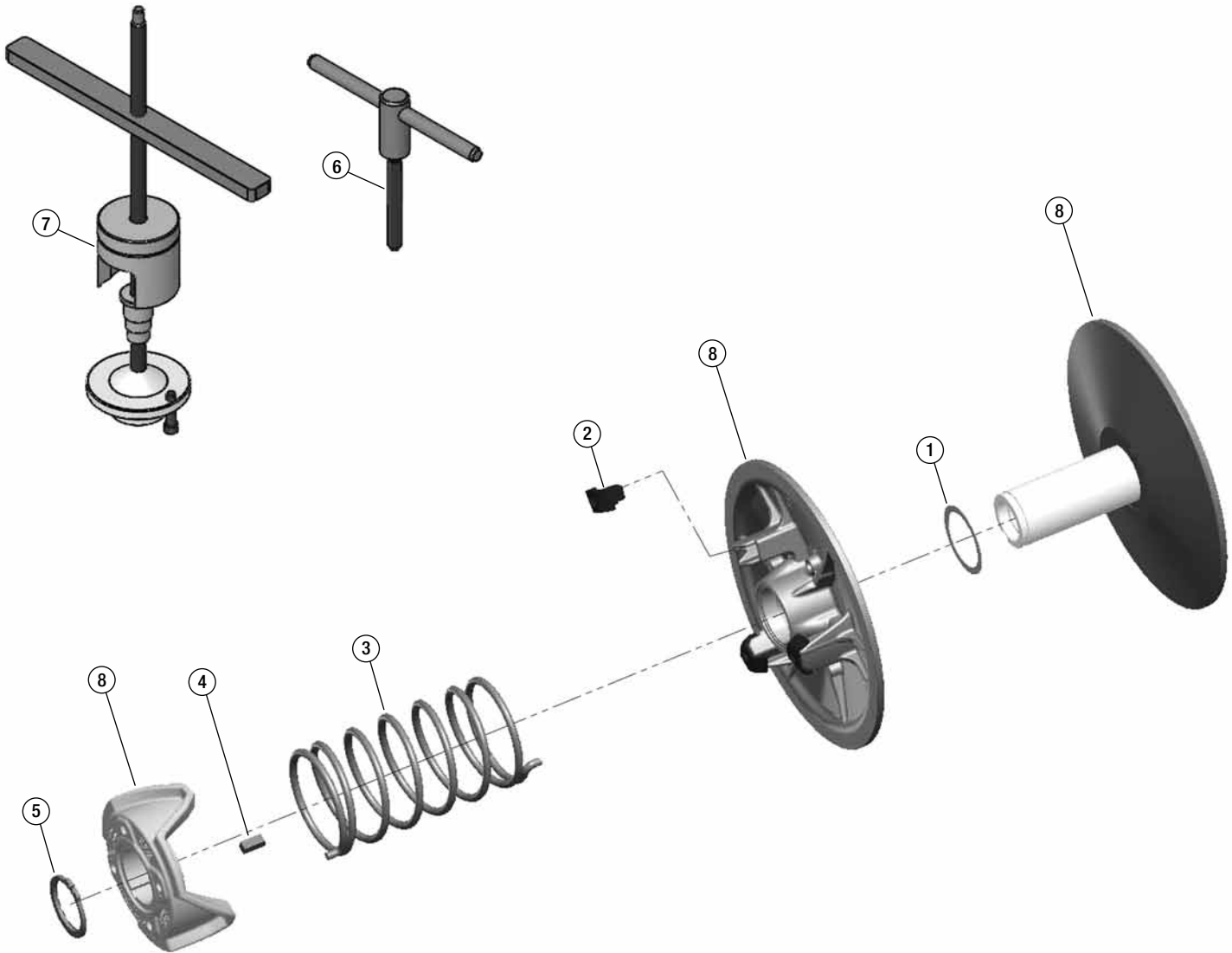

Ref#	Part#	Description	Qty
1	16390	WASHER	1
2	16391	CAM SHOE	3
3	16392	SPRING	1
4	16385	KEY	1
5	16386	EXTERNAL RETAINING RING	1
6	16387	DISASSEMBLY TOOL	1
7	16388	FLANGE SPREADER	1
8	2-20666	THIS PART IS ONLY AVAILABLE WITH THE ENTIRE ASSEMBLY	



ENTIRE ASSEMBLY (2-20666)

REFERENCE NUMBER	PART NUMBER	PART DESCRIPTION	QUANTITY REQUIRED
1		Frame, CW11	1
2	2-45401	Rear frame stub, CW - black	2
-	2-50168	5/16 x 2-1/4" USS Socket Head bolt	2
-	2-50007	nut, 5/16 nylock	2
-	2-50702	bent washer 5/16	2
3	2-45465	Trail Wagon Front Bumper	1
-	2-50167	bolt, 5/16 x 2	4
-	2-50007	nut, 5/16 nylock	4
-	2-50702	bent washer 5/16	4
-	2-70210	1.75" Round Tubing Plug	2
4	2-45412	Brush Guard roof, CW – black	1
-	2-50168	5/16 x 2-1/4" USS Socket Head bolt	4
-	2-50007	nut, 5/16 nylock	4
-	2-50702	bent washer 5/16	4
5	2-45411	brshgrd seat back, CW – black	1
-	2-50168	5/16 x 2-1/4" USS Socket Head bolt	2
-	2-50007	nut, 5/16 nylock	2
-	2-50702	bent washer 5/16	2
6	2-45404	A-arm upper, CW – black (left or right)	2
-	2-51102	suspension bushings	4 ea
-	2-50097	bolt, 3/8 x 8.5"	1 ea
-	2-50212	Bolt, 3/8 x 3.25 bolt	1 ea
-	2-10048	DOM 3/8" ID x 2.2"	2 ea
-	2-50010	Nylock Nut 3/8"-16	5 ea
-	2-50225	Bolt, 3/8" x 8"	2 ea
-	2-42114	Spacer, 3/8" ID 6.93"	2 ea
7	2-45405	A-arm Lower, CW – black (left or right)	2
-	2-51102	suspension bushings	4 ea
-	2-50097	bolt, 3/8 x 8.5"	1 ea
-	2-50221	Bolt, 3/8 x 3.25 bolt	1 ea
-	2-10048	DOM 3/8" ID x 2.2"	2 ea
-	2-50010	Nylock Nut 3/8"-16	2 ea
-	2-50225	Bolt, 3/8" x 8"	2 ea
-	2-42114	Spacer, 3/8" ID 6.93"	2 ea
8	2-45408	spindle mount, CW – black	2
9a	2-45406	Spindle, cw left – black	1
9b	2-45407	Spindle, cw right – black	1
-	2-51102	suspension bushings	2 ea
-	2-10049	DOM 3/8" ID x 7.5"	2 ea
10	2-30604	Hub, 4 bolt high speed 1" Complete with Bearings & Seals	2
-	2-25018	Wheel stud, 1/2 -20 X 1 5/8"	
-	2-11205	bearing, 1" tapered	
-	2-30620	seal	
-	2-30622	castle nut, 1"	
-	2-30621	cotter pin	
-	2-30623	Metal Dust Cap (Front Only)	2
-	2-70209	Rubber Dust Cap (Rear Only)	2
-	2-50060	Lug nuts, 1/2"	
11	2-70301	Shock, Heavy duty, Black/Yellow (Before Serial #52767)	6
-	2-70302	Shock, Heavy duty, Black (After Serial #52767)	

NOTE: parts denoted as left or right hand are from driver's point of view.

REFERENCE NUMBER	PART NUMBER	PART DESCRIPTION	QUANTITY REQUIRED
-	2-50400	Bolt, 10 mm x 40mm	12
-	2-50065	Nut, 10mm nylock	12
15L	2-30149	Rim/Tire Assembly, Black, UTV 25/11-12" Left	1
15R	2-30150	Rim/Tire Assembly, Black, UTV 25/11-12" Right	1
17L	2-30149	Rim/Tire Assembly, Black, UTV 25/11-12" Left	1
17R	2-30150	Rim/Tire Assembly, Black, UTV 25/11-12" Right	1
20	2-10521	Rack & pinion with rod ends	1
-	2-10593	Rack & Pinion Boots	2
-	N/A	Rack & Pinion Rod – Not available sold as assembly only (2-10521)	
-	2-50171	Bolt, 5/16 x 3 3/4" USS	4
-	2-50005	Nut, 5/16 keps	4
-	2-50063	Nut, 1/2" SAE nylock	2
21	2-10524	Rod end (use before serial #27213)	2
-	2-10589	Rod end (use after serial #27214)	2
-	2-50078	Nut, 1/2" SAE jam	2
22	2-10522	Steering Shaft w/u-joints	1
-	2-50402	Bolt, 10mm x 30mm	1
-	2-50066	Nut, 10mm Tri Lock Jam	1
-	2-50403	Bolt, 8mm x 30mm	1
-	2-50780	Lock washer, 8mm	1
23	2-10520	Steering Stub Shaft Double Splined	1
24	2-45462	Steering support, LM – black	1
-	2-51102	suspension bushings	2 ea
-	2-50152	bolt, 5/16 x 1	4
-	2-50005	Nut, 5/16 keps	4
25	14845	Steering Wheel (used for serial number 48598 and above)	1
-	14846	Center cap (used for serial number 48598 and above)	1
-	2-10508	Center cap (used for serial number 48598 and below)	1
-	2-10509	Steering Wheel (used for serial number 48598 and below)	1
26	2-18169	Steering Washer	1
-	2-50636	Bolt, 1/4 x 3/4 SS Socket Head	6
-	2-50001	Nut, 1/4 Nylock	6
-	2-50098	Tapered Bolt	1
30	2-42106	Pivot Pedal Asm, Black	1
-	2-70261	Pedal cover, rubber	2
-	2-50152	bolt, 5/16 x 1	6
-	2-50081	bolt, 1/4 x 1 3/4"	1
-	2-50159	bolt, 5/16 x 1 1/2	1
-	2-50005	Nut, 5/16 keps	8
-	2-50701	Washer, 5/16 flat	2
31	2-11181	Brake Rod, with clevis	1
-	2-50215	bolt, 3/8 x 1 1/4	1
-	2-50010	nut, 3/8" nylock	1
-	2-50801	cotter pin 1/8" x 1	1
32	2-45417	parking brake bar, CW – black	1
-	2-50806	Clevis, 5/16 rod end	1
-	2-50170	Bolt, 5/16"-24 X 4" SAE	1
-	2-50077	Nut, 5/16" Hex SAE	1
-	2-50087	bolt, 1/4" x 1	1
-	2-50001	nut, 1/4" nylock	1

NOTE: parts denoted as left or right hand are from driver's point of view.

REFERENCE NUMBER	PART NUMBER	PART DESCRIPTION	QUANTITY REQUIRED
33	2-11127	Parking Brake	1
-	2-50086	Bolt, ¼ x 1 ¼	1
-	2-50001	nut, ¼" nylock	1
-	2-50163	bolt, 5/16 x ¾" NC	4
-	2-50005	Nut, 5/16 keps	4
-	2-50701	Washer, 5/16 flat	4
36	2-45415	Brake equalizer, CW (2 ½") – black	1
-	2-50215	bolt, 3/8 x 1 ¼	2
-	2-50010	nut, 3/8" ny-lock	2
37	2-45522	Shifter control assembly, black (used on units built after 2-1-05)	1
-	2-11080	Shifter Cable and Shifter Control (used on units built before 2-1-05)	1
-	2-11082	Cable, shifter (used on units built after 2-1-05)	2
-	2-11093	Knob, Shifter imprinted	1
-	2-50053	nut, #10-24 Keps nut	2
-	2-50616	screw, #10-24 X ¾" Pan Head Phillips	2
-	2-50770	Washer, #10 flat	2
38	2-45522	Differential Control assembly with cable and knob	1
-	2-11092	Knob, Differential imprinted	1
-	2-11094	Cable, Differential lock	1
-	2-50053	nut, #10-24 Keps nut	2
-	2-50616	screw, #10-24 X ¾" Pan Head phillips	2
-	2-50770	Washer, #10 flat	2
39	2-11053	Choke Cable	1
40	2-70012	Wire Harness	1
41	2-70000	Battery, U1L-HDJ7-UTV - 360CCA	1
-	2-70002	Battery Cable, Red – 19"	1
-	2-70010	Battery Cable, Black (27")	1
-	2-70009	Battery Terminal Cover	2
-	2-50087	bolt, ¼" x 1	2
-	2-50000	nut, ¼" keps	2
42	2-45414	Battery strap, CW (8 ¾") – black	1
-	2-50083	bolt, ¼ x 7 ½	2
-	2-50002	nut, ¼" wing	2
43	2-70066	Headlight Switch	1
44	2-70052	Key Switch (keys not included) USED ON VEHICLES MANUFACTURED BEFORE SERIAL NUMBER 58843	1
-	2-70060	Key USED ON VEHICLES MANUFACTURED BEFORE SERIAL NUMBER 58843	1
-	2-70093	Key Switch (keys included) USED ON VEHICLES MANUFACTURED AFTER SERIAL NUMBER 58843	1
-	2-70092	Key set (includes 2 keys) USED ON VEHICLES MANUFACTURED AFTER SERIAL NUMBER 58843	1
45	2-70080	Accessory Plug	1
-	2-70081	Accessory Plug cap	1
46	2-18500	Terminal Block Cover – plastic	1
-	2-50625	screw, #10-24 X 1" Pan Head Phillips	2
-	2-50053	nut, #10-24 Keps nut	2
47	SEE LAST PAGE FOR HEADLIGHT INFORMATION		
50	2-18334	Hood, UTV - red (LM)	
-	15977	Hood LM, "Spencer" Green	1
-	2-18342	Hood, UTV - white (LM)	
-	2-18346	Hood, UTV - camo (LM)	
-	2-18348	Hood, UTV - black (LM)	
50a	2-18341	UTV Grill LM Black	1

NOTE: parts denoted as left or right hand are from driver's point of view.

REFERENCE NUMBER	PART NUMBER	PART DESCRIPTION	QUANTITY REQUIRED
50b	15978	UTV Dash LM Black	1
-	2-50817	Push Pin Black Plastic	16
-	2-50621	¼" x 2" Phillip Head Machine Screw	1
-	2-50001	nut, ¼" nylock	1
-	2-50846	Clamp-Tube-vinyl coated 1-1/4"	2
51	2-18309	Glove Box	1
-	2-50624	Screw, #10 x ¾ hex – black	5
53	2-18306	Center Console	1
-	2-50624	Screw, #10 x ¾ hex – black	14
54	2-18316	Access Cover, Center Console	1
-	2-50624	Screw, #10 x ¾ hex – black	4
55	2-18305	Plastic, Seat Bottom wrap	1
-	2-50624	Screw, #10 x ¾ hex – black	5
56	2-18355	Under seat storage box	1
57	2-18303	Rear Fender, Universal	2
-	2-50001	nut, ¼ nylock	4
-	2-50091	Bolt, ¼"-20 X ¾" Hex Head	4
-	2-50717	¼" SAE Flat washer	4
-	2-70150	Reflectors	2
58	2-55069	Fuel Tank, Flambeau (used on units BEFORE serial number 58908)	1
-	2-55077	Fuel Tank, QMI (used on units AFTER serial number 58908)	1
-	15698	Clamp, 3/8 Spring Tube	1
-	2-65503	UTV, Fuel Line 3/16" black	1
-	2-55063	Elbow Fuel Inlet with #200 Mesh Screen	1
-	2-55062	Fuel Fitting Grommet	1
-	2-55073	Fuel Tank Cap (used with Flambeau fuel tank)	1
-	2-55066	Fuel Tank Cap (used on units AFTER serial number 58908 with QMI opaque fuel tank)	1
-	2-55071	Fuel Tank Straps	2
-	2-50010	Nut, 3/8 Nylock	4
-	2-50740	Washer, 3/8 Flat	4
60	2-10771	Seat back – BLACK & GREY – 43 ½ x 17 ½	1
60	2-10754	Seat back – BLACK – 43 ½ x 17 ½	1
-	2-50619	#14 X 1-3/4" Pan head-Tapping screw	6
61	2-10773	Headrest – BLACK & GREY – 9 x 6 ½	2
61	2-10803	Headrest – BLACK – 9 x 6 ½	2
-	2-50085	bolt, ¼ x 1 ½"	4
62	2-10772	Seat bottom – BLACK & GREY – 43 ½ x 17 ½	1
62	2-10755	Seat bottom – BLACK – 43 ½ x 17 ½	1
63	2-45416	seat bar, CW (17 ½") – black	2
-	2-50609	#14 x ¾ Pan Head Screw	6
65	14786	Seatbelt, retractable without sleeve	2
-	8375	Seatbelt plastic sleeve - 7" length	2
-	2-50025	7/16 Nylock	4
70	2-18356	Dump Bed UTV Plastic	1
-	2-50255	5/8 x 4" bolt Zinc plate	2
-	2-50015	5/8 nylock	2
-	2-18413	Bed Bumper 3/8" Rubber	2
73	2-50208	Bed latch bolt, 3/8 x 2 1/2"	1
-	2-50013	nut, 3/8 keps	2
-	2-50740	washer, 3/8 flat	2

NOTE: parts denoted as left or right hand are from driver's point of view.

REFERENCE NUMBER	PART NUMBER	PART DESCRIPTION	QUANTITY REQUIRED
75	2-18357	Dump Bed Tailgate UTV Plastic	1
80	2-18328	Roof, Black Textured	1
-	2-18390	Roof, Hardware bolt kit	
-	2-50847	Clamp-Tube-vinyl coated 1-3/4"	4
-	2-50087	bolt, 1/4" x 1	4
-	2-50718	Washer, 1/4" rubber domed	4
-	2-50001	nut, 1/4" nylock	4
85	2-18411	Windshield - clear	
-	2-18403	Fastener kit, windshield	
88	2-40723	Front receiver hitch kit	
101	2-20012	Engine, Honda 390cc	1
-	2-50202	3/8-16 x 1 3/4" Hex Hd Bolt	4
-	2-50740	3/8" Flat washer, USS	4
102	2-20833	Dana Transaxle	1
-	2-70057	Neutral Safety Switch	1
-	2-51500	Shims – Neutral Safety Switch	
103	2-45423	Swing arm, CW - Black	1
104	2-45430	Motor Plate, CW - Black	1
105	2-18023	Throttle Guard Laser	1
-	2-50086	1/4-20 x 1 1/4" Hex Hd Bolt	3
-	2-50082	1/4-20 x 2 1/4" Hex Hd Bolt	1
-	2-50000	1/4" Keps Nut	5
-	2-50715	1/4" Flatwasher, USS	8
-	2-20665	TC, Driver CVTECH (used after Serial Number # 25658) (parts list on page 5)	1
-	2-20666	TC, Driven CVTECH (used after Serial Number # 25658) (parts list on page 6)	1
109	16279	Brake Shoes - Rear UTV – Dana (kit includes 4 shoes to cover both rear wheels)	1
109b	2-11191	Brake Drum Replacement #012WA123	2
111	2-10190	3/16 x 1/4 x 1-1/2" Keystock (for use with CV Tech driver pulley)	1
-	2-20694	Belt, CV TECH – used after Serial Number # 25658	1
116	2-50239	1/2 x 2" SAE	1
117	2-50722	1/2" Lock Washer	1
-	2-50721	1/2" Uss Flat Washer	1
118	2-10191	3/16 x 3/16 x 3-1/4" Keystock (for use with CV Tech driven pulley)	1
119	2-45431	Tension Mount Engine, CW - Black	1
-	2-50157	5/16x 3/4" Bolt Hex Hd NF	2
-	2-50703	5/16" Lock Washer	2
-	2-50704	5/16" Flatwasher	2
120	2-70251	Rubber Feet (Isolators)* SEE NOTE ON NEXT PAGE	4
120a	2-70252	Rubber Feet (Isolator)* SEE NOTE ON NEXT PAGE	1
-	2-50010	3/8 Nylock Nut	10
-	2-50740	3/8 Flatwasher USS	5
121	2-10583	Rod End Sphcl-UTV (4681-MPM-12)	3
122	2-50021	3/4 Jam nut SAE	3
123	2-42093	Panhard bar, CW - black	1
124	2-50206	bolt, 3/8 x 1	4
-	2-50010	3/8" Nylock Nut	4
-	2-50740	3/8" Flatwasher, USS	4
125	2-50730	3/4' Spacer Washer	6
126	2-50280	3/4 x 2.5 SAE bolt	3
127	2-50020	3/4 SAE nylock	3

NOTE: parts denoted as left or right hand are from driver's point of view.

REFERENCE NUMBER	PART NUMBER	PART DESCRIPTION	QUANTITY REQUIRED
128	2-18012	shifter lever, CW - black	1
-	2-50084	1/4-20 x 3/4" Hex Hd Bolt	1
-	2-50000	1/4" Keps Nut	2
129	2-18011	shifter cable mount, CW - black (used after Serial Number #15245)	1
-	2-50000	1/4" Keps Nut	1
-	2-50715	1/4" Flatwasher, USS	2
130	2-11103	Brake Cables	2
-	2-50150	5/16-18 x 1" Hex Hd Bolt	2
-	2-50007	5/16" Nylock Nut	2
131	2-11010	Throttle Cable, UTV	1
-	2-50087	1/4-20 x 1" Hex Hd Bolt	1
-	2-50000	1/4" Keps Nut	2
-	2-11804	Spring #80704 Black painted	1
132	2-11084	Differential Cable All 2WD models (before serial #22187)	1
-	2-50087	1/4-20 x 1" Hex Hd Bolt	1
-	2-50000	1/4" Keps Nut	2
-	2-50159	5/16-18 x 1 1/2" Hex Hd Bolt	1
-	2-50005	5/16" Keps Nut	2
132	2-11084	Differential Cable All 2WD models (before serial #22187)	1
-	2-45522	Differential Control Assembly with cable (all models after serial # 22187)	1
-	2-11094	Differential Control Cable Only (used on all models after serial # 22187)	1
-	2-50087	1/4-20 x 1" Hex Hd Bolt	1
-	2-50000	1/4" Keps Nut	2
-	2-50159	5/16-18 x 1 1/2" Hex Hd Bolt	1
-	2-50005	5/16" Keps Nut	2
-	2-11092	Knob, Differential Imprinted	1
-	2-50053	nut, #10-24 Keps nut	2
-	2-50616	screw, #10-24 X 3/4" Pan Head phillips	2
-	2-50770	Washer, #10 flat	2
133	2-11804	Spring #80704 Black painted	1
135	2-11080	Shifter Cable and Shifter Control - used before Serial Number #15244	1
-	2-11082	Cable, shifter - used after Serial Number #15245	2
136	2-65500	fuel hose 3/16" dia - 24"	1
137	2-50849	hose clamps - small	3
138	2-18313	Belt Guard Plastic UTV - Front	1
139	2-18314	Belt Guard Plastic UTV - Rear	1
140	2-18315	Belt Guard Plastic UTV - Bottom	1
-	2-50624	#10 x 3/4" Blunt Point Black	7
-	2-50050	#10 Speed Nut - for Plastic	7
-	2-50770	#10 Flat washer	7
141	2-20011	Choke Bracket Honda Engine	1
ADDITIONAL PARTS FOR "S" MODELS WITH STEEL BED / REAR FLIPSEAT			
-	2-45424	Steel Bed Black	1
-	2-45425	Steel Tailgate Black	1
-	2-70230	Rubber, Bumper – Dome - Large	2
-	2-55094	Flip Seat Kit-UTV	1

* On single cylinder models, quantity 5 of 2-70250 was replaced by quantity 4 of 2-70251 and 1 of 2-70252 on 6/1/2012. The 4 of the 2-70251 go under the engine and the 1 of the 2-70252 goes in the vertical mount. We do not recommend replacing only one bushing and that all four bushings should be replaced together.

NOTE: parts denoted as left or right hand are from driver's point of view.

pub. 06/19/17

HEADLIGHT REPLACEMENT BULBS AND ASSEMBLIES FOR ASW UTILITY VEHICLES

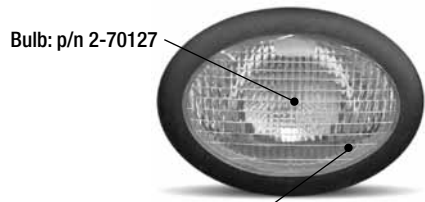

Bulb: p/n 2-70127

Assembly: p/n 2-70129
(5 1/4" oval)

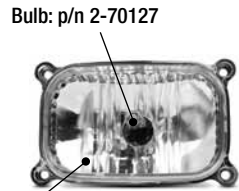

Bulb: p/n 2-70127

Assembly: p/n 2-70133
(4 3/8" rectangle)



Bulb: p/n 2-70127

Assembly: p/n 15648
(3 1/4" Round)



Bulb: Sealed housing
no bulb available

Assembly: p/n 14768
(4" round)



Light assembly: p/n 2-70158
(5" round)

Amber reflector: p/n 14784
(2 1/4" Round)

Bulb: p/n 2-70122

Plastic insert: p/n "Driver Side" 15944 (inner bezel)
15946 (outer bezel)

Plastic insert: p/n "Passenger Side" 15943 (inner bezel)
15945 (outer bezel)

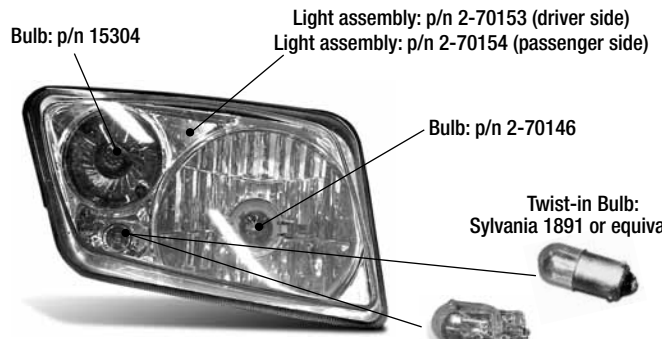

Bulb: p/n 15304

Light assembly: p/n 2-70153 (driver side)
Light assembly: p/n 2-70154 (passenger side)

Bulb: p/n 2-70146

Twist-in Bulb:
Sylvania 1891 or equivalent



Depending on your year of manufacture,
this housing either has a "push-in" or "twist-in" bulb

Push-in Bulb:
Sylvania 2825 or equivalent



Measurements are taken from left to right of the visible portion of the lens

ORDERING PARTS

FAST & EASY!

LOWEST PRICE!

1) Seek Part(s) from your models illustrated diagram, cross over REF# to PART#

2) Type PART# into sites [Search Box] at GoKartsRus.com TIP! - RIGHT CLICK LINK, SELECT OPEN IN NEW TAB

3) Add all needed parts to Shopping Cart | Complete "Checkout" | ✓ Done!

If a part does not come up in a Site Search, please [Contact Us](#) (include part# in email)