

LM700 INDEPENDENT REAR SUSPENSION

WITH 653cc SUBARU ENGINE

ORDERING PARTS

FAST & EASY!

- 1) Seek Part(s) from your models illustrated diagram, cross over REF# to PART#
- 2) Type PART# into sites [Search Box] at GoKartsRus.com TIP! - RIGHT CLICK LINK, SELECT OPEN IN NEW TAB
- 3) Add all needed parts to Shopping Cart | Complete "Checkout" | ✓ Done!

If a part does not come up in a Site Search, please [Contact Us](#) (include part# in email)

LOWEST PRICES!



unit shown with optional accessories



NOTE:

Some part numbers vary by serial number.
The serial number is located on a brass tag
beneath the dump bed on the driver side.

653CC 4 WHEEL DRIVE UTILITY VEHICLE

ILLUSTRATED PARTS LIST

BODY

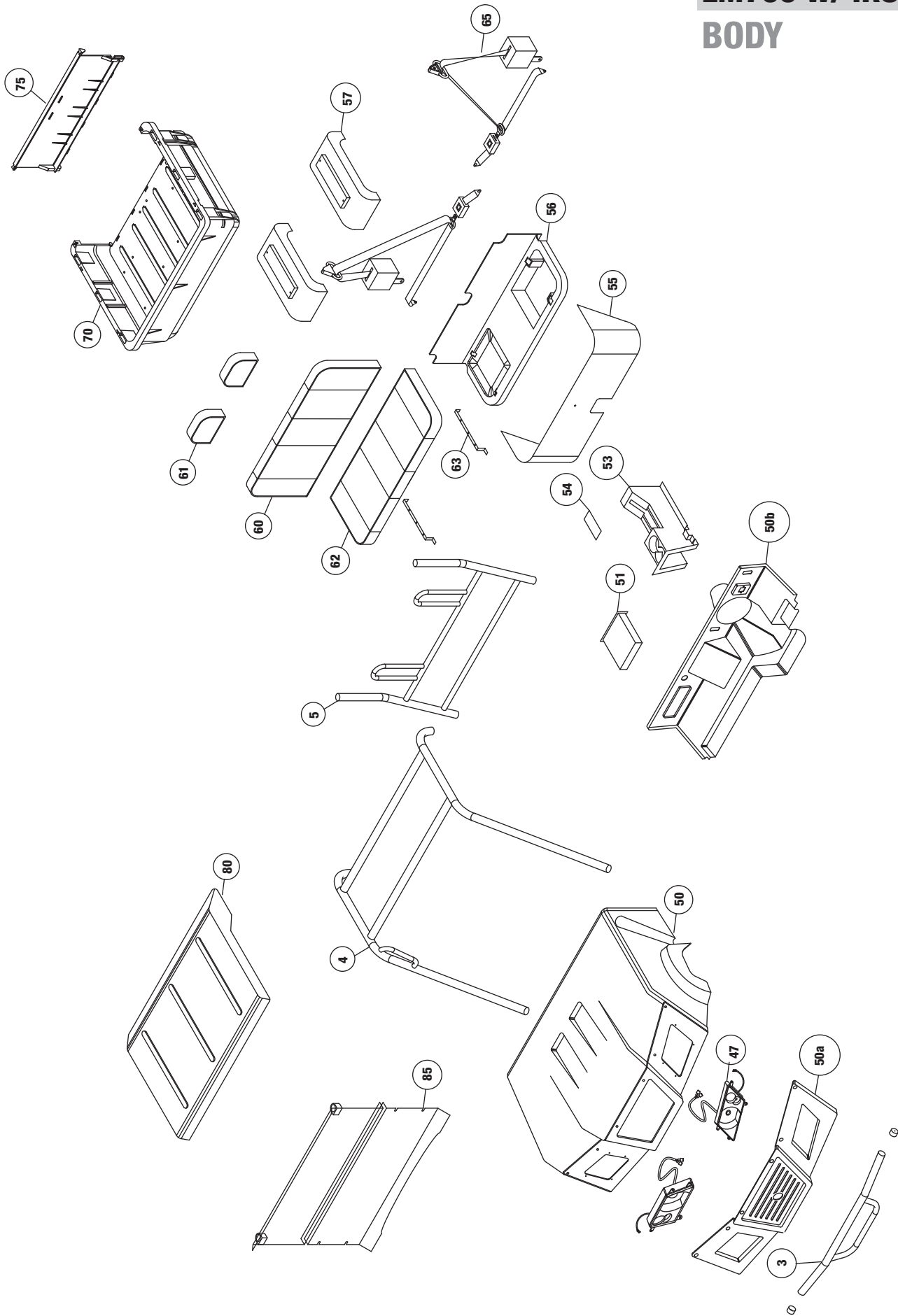

FRAME

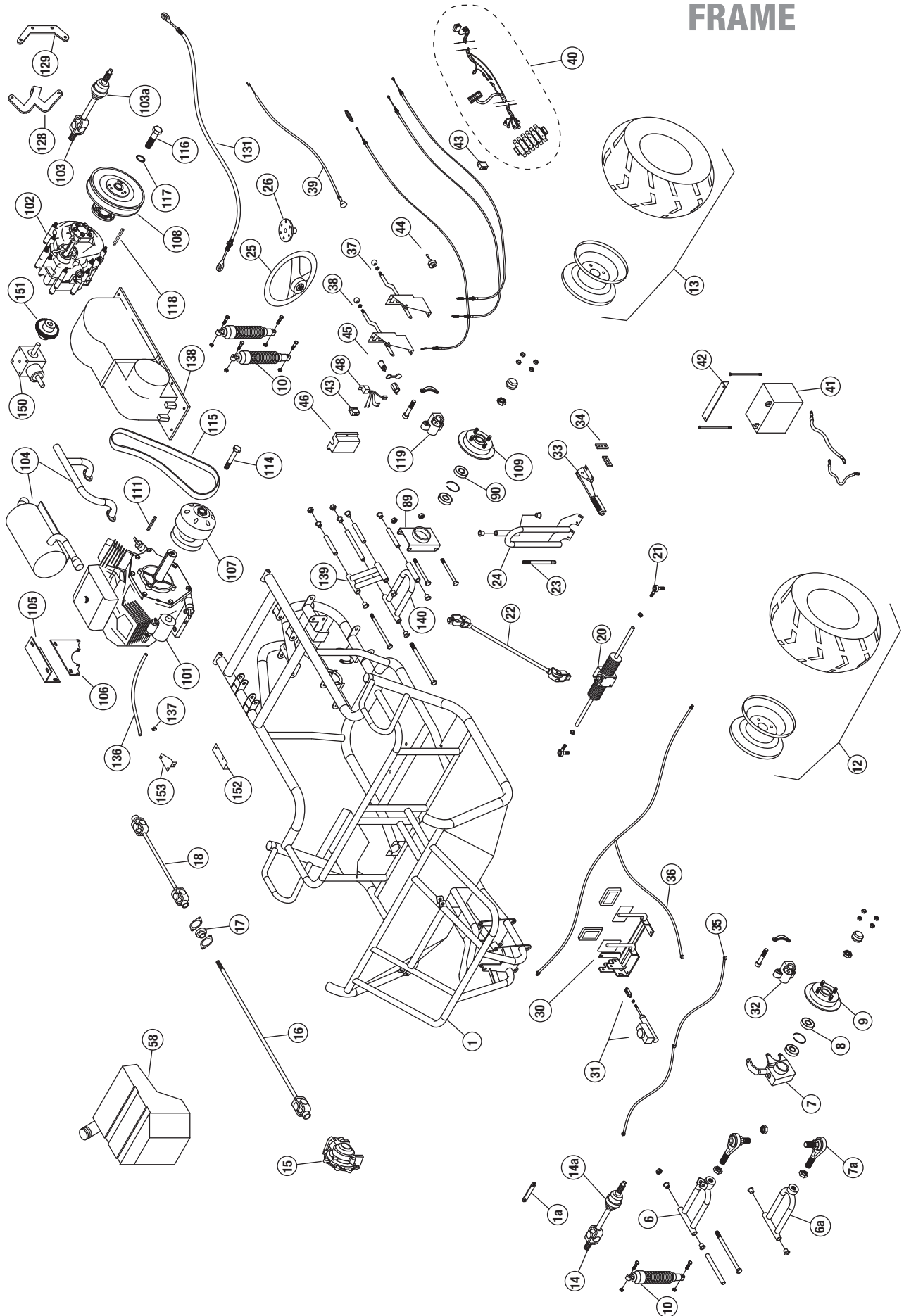

NOTE: parts denoted as left or right hand are from driver's point of view.

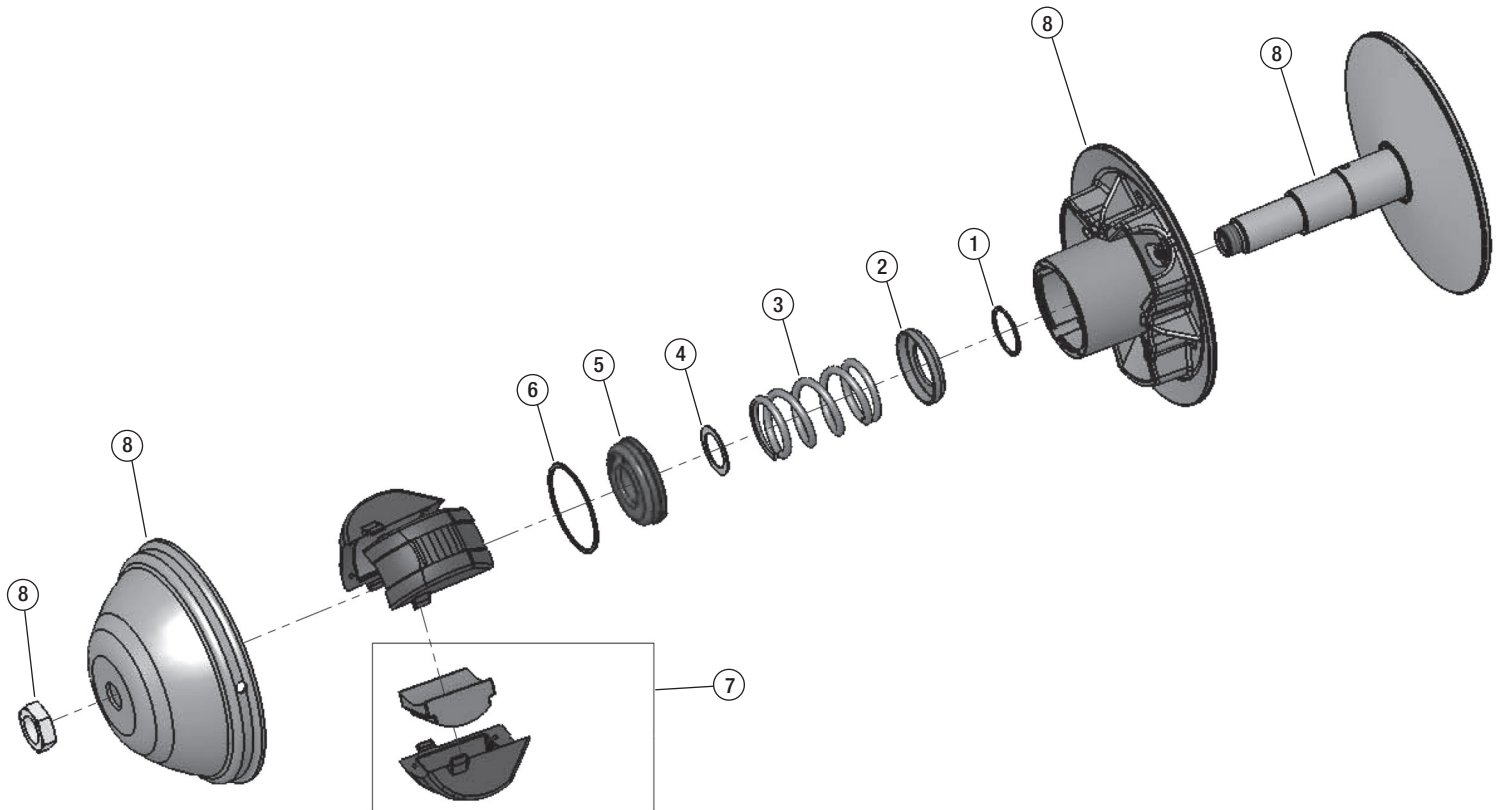

Ref#	Part#	Description	Qty
1	16374	WASHER	1
2	16375	SPRING GUIDE	1
3	16376	SPRING	1
4	16377	SHIM	1
5	16378	EXTERNAL BUSHING	1
6	16379	INTERNAL SNAP RING	1
7	16380	CENTRIFUGAL MASS	3
8	2-20662	THIS PART IS ONLY AVAILABLE WITH THE ENTIRE ASSEMBLY	



ENTIRE ASSEMBLY (2-20662)

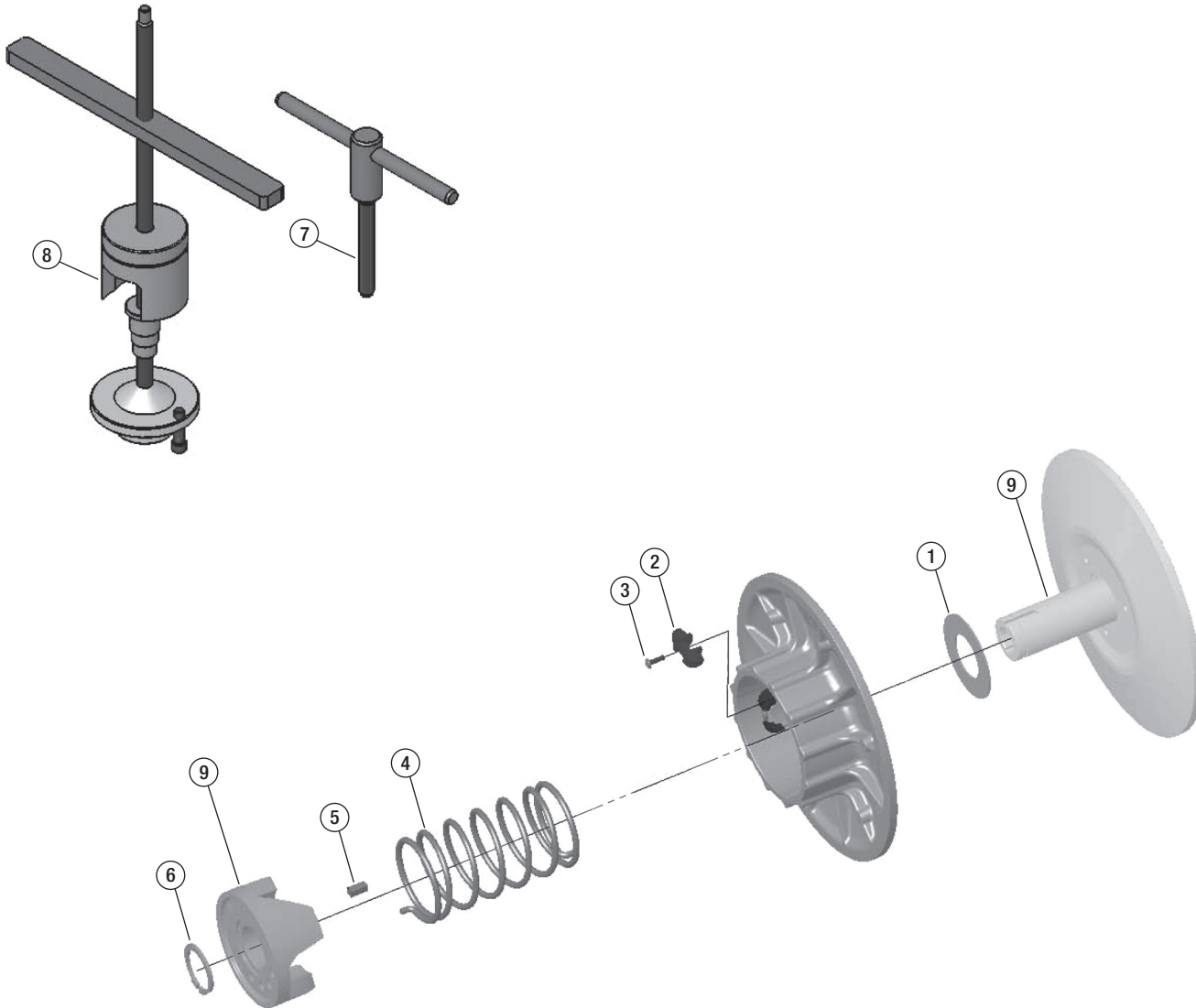

Ref#	Part#	Description	Qty
1	16381	WASHER	1
2	16382	CAM SHOE	3
3	16383	SCREW	3
4	16384	SPRING	1
5	16385	KEY	1
6	16386	SNAP RING	1
7	16387	DISASSEMBLY TOOL	1
8	16388	FLANGE SPREADER	1
9	2-20661	THIS PART IS ONLY AVAILABLE WITH THE ENTIRE ASSEMBLY	



ENTIRE ASSEMBLY (2-20661)

REFERENCE NUMBER	PART NUMBER	PART DESCRIPTION	QUANTITY REQUIRED
1		Frame, - LM700 IRS 4x4	1
1a	2-18112	Tie Bar (metal strip to connect A-arm mount front)	1
2	2-45401	Rear frame stub, CW - black	2
-	2-50206	bolt, 3/8 x 1	8
-	2-50013	nut, 3/8 keps	8
3	2-45439	Landmaster Front Bumper	1
-	2-50167	bolt, 5/16 x 2	4
-	2-50007	nut, 5/16 nylock	4
-	2-50702	bent washer 5/16	4
-	2-70210	1.75" Round Tubing Plug	2
4	2-45412	brshgrd roof, CW - black	1
-	2-50168	5/16 x 2-1/4" USS Socket Head bolt	4
-	2-50007	nut, 5/16 nylock	4
-	2-50702	bent washer 5/16	4
5	2-45411	brshgrd seat back, CW - black	1
-	2-50172	5/16 x 2" USS Socket Head bolt	2
-	2-50007	nut, 5/16 nylock	2
-	2-50702	bent washer 5/16	2
6	2-45445	A-arm, 4x4 Double A-arm Front UPPER - black	2
6a	2-45446	A-arm, 4x4 Double A-arm Front LOWER - black	2
-	2-51102	suspension bushings	2 ea
-	2-50225	bolt, 3/8 x 8"	1 ea
-	2-50010	Nut, 3/8 nylock	1 ea
-	2-42114	spacer, 3/8 ID 6.93" in length	1 ea
7	2-40554	Spindle Welded assembly, left (After Serial# 47273)	1
-	2-40558	Spindle Welded assembly, left (Before Serial# 47273)	
-	2-40555	Spindle Welded assembly, right (After Serial# 47273)	1
-	2-40559	Spindle Welded assembly, right (Before Serial# 47273)	
-	15839	Spindle Box, left - COMPLETE ASSEMBLY includes 1 brake rotor (2-25011) and 2 bearings (2-25021)	1
-	15840	Spindle Box, right - COMPLETE ASSEMBLY includes 1 brake rotor (2-25011) and 2 bearings (2-25021)	1
7a	2-10598	Rod End (Heim Joint) 3/4" Studded	4
-	2-25022	Snap Ring	4
8	2-25021	Front Spindle Bearing	4
-	2-50021	Nut, 3/4 JAM	4
9	2-25011	Hub / 8.75" Brake Rotors (front)	2
-	2-25018	Wheel stud, 1/2 -20 X 1 5/8"	
-	2-50073	Nut, 5/8 Half Nylock	2
10	14535	Shock, Heavy Duty, Chrome/Yellow	2
-	2-30623	Metal Dust Cap	2
-	2-50060	Lug nuts, 1/2"	16
11	2-70301	Shock, Rear, Black/Yellow (Before Serial #52767)	4
-	2-70302	Shock, Rear, Black (After Serial #52767)	4
-	2-50400	Bolt, 10 mm x 40mm	6
-	2-50404	10 mm x 70mm bolt	2
-	2-50065	Nut, 10mm nylock	8
-	2-45150	spacer, shock	2
12L	2-30149	Rim/Tire Assembly, UTV 25/11-12" Left	1
12R	2-30150	Rim/Tire Assembly, UTV 25/11-12" Right	1
-	2-30481	Wheel rim, 12"	
-	2-30481-B	Wheel rim, 12" - Black	

NOTE: parts denoted as left or right hand are from driver's point of view.

REFERENCE NUMBER	PART NUMBER	PART DESCRIPTION	QUANTITY REQUIRED
-	2-30199	UTV 25/11-12 Tire only	
13L	2-30149	Rim/Tire Assembly, UTV 25/11-12" Left	1
13R	2-30150	Rim/Tire Assembly, UTV 25/11-12" Right	1
-	2-30481	Wheel rim, 12"	
-	2-30481-B	Wheel rim, 12" - Black	
-	2-30199	UTV 25/11-12 Tire only	
14	2-20851	CV half shaft (axle) (before serial #41746)	2
-	2-20863	CV half shaft (axle) (after serial #41746)	2
14a	2----->	CV Boot (P/N 2-20868 fits 2.5" bell / 2-20873 fits 3" bell) 1 per half shaft	
15	2-20839	front differential - 4x4	1
-	2-50206	Bolt, 3/8 x 1	4
-	2-50740	washer, 3/8 flat	4
-	2-50741	washer, 3/8 lock	4
16	2-25015	drive shaft, front	1
-	2-50092	bolt, 1/4 x 2"	2
-	2-50000	nut, 1/4 keps	2
17	2-25010	bearing, shaft support	1
-	2-50163	bolt, 5/16 x 3/4" NC	2
-	2-50005	Nut, 5/16 keps	2
18	2-25016	drive shaft, rear	1
-	2-50628	Screw, 1/4-20 x 1/2" square head set	1
-	2-10184	key, 3/16 x 1	3
20	2-10596	Rack & Pinion, 4x4 Double A-arm	1
-	2-50171	Bolt, 5/16 x 3 3/4" USS	4
-	2-50005	Nut, 5/16 keps	4
21	2-10589	Rod end 4x4	2
-	2-10593	Rack boot	2
22	2-10526	Steering Shaft with U-joints 4x4	1
-	2-50402	Bolt, 10mm x 30mm	1
-	2-50066	Nut, 10mm Tri Lock Jam	1
-	2-50403	Bolt, 8mm x 30mm	1
-	2-50780	Lock washer, 8mm	1
23	2-10520	Steering Stub Shaft Landmaster Double Splined	1
24	2-45462	Steering support, LM - black	1
-	2-51102	suspension bushings	2 ea
-	2-50152	bolt, 5/16 x 1	4
-	2-50005	Nut, 5/16 keps	4
25	14845	Steering Wheel (used for serial number 48598 and above)	1
-	14846	Center cap (used for serial number 48598 and above)	1
-	2-10508	Center cap (used for serial number 48598 and below)	1
-	2-10509	Steering Wheel (used for serial number 48598 and below)	1
26	2-18169	Steering Washer	1
-	2-50636	Bolt, 1/4 x 3/4	6
-	2-50001	Nut, 1/4 Nylock	6
-	2-50098	Tapered Bolt	1
30	2-42106	Pivot Pedal Asm, Black	1
1	2-70261	Pedal cover, rubber	2
-	2-50152	bolt, 5/16 x 1	6
-	2-50081	bolt, 1/4 x 1 3/4"	1
-	2-50159	bolt, 5/16 x 1 1/2"	1

NOTE: parts denoted as left or right hand are from driver's point of view.

REFERENCE NUMBER	PART NUMBER	PART DESCRIPTION	QUANTITY REQUIRED
-	2-50005	Nut, 5/16 keps	8
-	2-50701	Washer, 5/16 flat	2
31	2-11120	master cylinder	1
-	2-50167	bolt, 5/16 x 2	2
-	2-50005	Nut, 5/16 keps	2
-	2-50806	Clevis, 5/16 rod end	1
-	2-50077	Nut, 5/16" Hex SAE	1
32	2-11124	Brake caliper (Front) (pads not included)	2
-	2-11167	Brake pads (individual)	4
-	2-11168	Caliper Bolts	4
-	2-11169	Caliper Clips	4
33	2-11127	Parking Brake	1
-	2-50086	Bolt, 1/4 x 1 1/4	1
-	2-50001	nut, 1/4" nylock	1
-	2-50163	bolt, 5/16 x 3/4" NC	4
-	2-50005	Nut, 5/16 keps	4
-	2-50701	Washer, 5/16 flat	4
34	2-18038	Brake spreader	2
-	2-50152	bolt, 5/16 x 1	4
-	2-50007	nut, 5/16 nylock	1
35	2-11135	Brake hose, front	1
36	2-11140	Brake hose, rear	1
37	2-45522	Shifter Assembly	1
-	2-11093	Knob, Shifter Imprinted	1
-	2-11082	Cable, shifter	2
-	2-50053	nut, #10-24 Keps nut	2
-	2-50616	screw, #10-24 X 3/4" Pan Head phillips	2
-	2-50770	Washer, #10 flat	2
38	2-45522	Differential Control Assy	1
-	2-11092	Knob, Differential Imprinted	1
-	2-11094	cable, diff lock	
-	2-50053	nut, #10-24 Keps nut	2
-	2-50616	screw, #10-24 X 3/4" Pan Head phillips	2
-	2-50770	Washer, #10 flat	2
-	2-50087	1/4-20 x 1" Hex Hd Bolt	1
-	2-50000	1/4" Keps Nut	2
-	2-50159	5/16-18 x 1 1/2" Hex Hd Bolt	1
-	2-50005	5/16" Keps Nut	2
39	2-11053	Choke Cable	1
40	2-70068	Wire Harness - 653cc	1
40a	2-70094	Key Switch Adapter Harness	1
41	2-70000	Battery, U1L-8250-UTV	1
-	2-70002	Battery Cable, Red - 19"	1
-	2-70010	Battery Cable, Black 27"	1
-	2-70009	Battery Terminal Cover	2
-	2-50087	bolt, 1/4" x 1	2
-	2-50000	nut, 1/4" keps	2
42	2-45414	Battery strap, CW (8 3/4") - black	1
-	2-50083	bolt, 1/4 x 7 1/2	2
-	2-50002	nut, 1/4" wing	2

NOTE: parts denoted as left or right hand are from driver's point of view.

REFERENCE NUMBER	PART NUMBER	PART DESCRIPTION	QUANTITY REQUIRED
43	2-70066	Headlight Switch	1
-	2-70067	Printed Switch 4WD/2WD	1
44	2-70058	Key Switch (keys included) USED ON VEHICLES MANUFACTURED BEFORE SERIAL NUMBER 58843	1
-	2-70060	Key USED ON VEHICLES MANUFACTURED BEFORE SERIAL NUMBER 58843	1
-	2-70093	Key Switch (keys included) USED ON VEHICLES MANUFACTURED AFTER SERIAL NUMBER 58843	1
-	2-70092	Key set (includes 2 keys) USED ON VEHICLES MANUFACTURED AFTER SERIAL NUMBER 58843	1
45	2-70080	Accessory Plug	1
-	2-70081	Accessory Plug cap	1
46	2-18500	Terminal Block Cover - plastic	1
-	2-50625	screw, #10-24 X 1" Pan Head phillips	2
-	2-50053	nut, #10-24 Keps nut	2
47	SEE LAST PAGE FOR HEADLIGHT INFORMATION		
48	2-70019	Relay w/harness, 4x4	1
50	2-18334	Hood LM, Red	1
-	15977	Hood LM, "Spencer" Green	1
-	2-18346	Hood LM, Camo	1
-	2-18342	Hood LM, White	1
50a	2-18341	UTV Grille LM Black	1
50b	15979	UTV Dash LM Black	1
-	2-50817	Push Pin Black Plastic	16
-	2-50621	¼" x 2" Phillip Head Machine Screw	1
-	2-50001	nut, 1/4" nylock	1
-	2-50846	Clamp-Tube-vinyl coated 1-1/4"	2
51	2-18309	Glove Box	1
-	2-50624	Screw, #10 x 3/4 hex - black	5
53	2-18383	Center Console 4x4	1
-	2-50624	Screw, #10 x 3/4 hex - black	14
54	2-18316	Access Cover, Center Console	1
-	2-50624	Screw, #10 x 3/4 hex - black	4
55	2-18382	Plastic, Seat Bottom wrap 4x4	1
-	2-50624	Screw, #10 x 3/4 hex - black	5
56	2-18355	Underseat storage box	1
57	2-18303	Rear Fender - Universal	2
-	2-50001	nut, 1/4 nylock	4
-	2-50087	Bolt, 1/4"-20 X 3/4" Hex Head	4
-	2-50717	1/4" SAE Flat washer	4
58	2-55069	Fuel Tank, Flambeau (used on units BEFORE serial number 58908)	1
-	2-55077	Fuel Tank, QMI (used on units AFTER serial number 58908)	1
-	15698	Clamp, 3/8 Spring Tube	1
-	2-65503	UTV, Fuel Line 3/16" black	1
-	2-55063	Elbow Fuel Inlet with #200 Mesh Screen	1
-	2-55062	Fuel Fitting Grommet	1
-	2-55073	Fuel Tank Cap (used with Flambeau fuel tank)	1
-	2-55066	Fuel Tank Cap (used on units AFTER serial number 58908 with QMI opaque fuel tank)	1
-	2-55071	Fuel Tank Straps	2
-	2-50010	Nut, 3/8 Nylock	4
-	2-50740	Washer, 3/8 Flat	4
59	2-18033	Shaft guard	1
-	2-50163	bolt, 5/16 x 3/4" NC	3
-	2-50005	Nut, 5/16 keps	4

NOTE: parts denoted as left or right hand are from driver's point of view.

REFERENCE NUMBER	PART NUMBER	PART DESCRIPTION	QUANTITY REQUIRED
-	2-50171	Bolt, 5/16 x 3 3/4" USS	1
-	2-45506	Drive Shaft Cover Spacer - Black	1
60	2-10771	Seat back – BLACK & GREY – 43 ½ x 17 ½	1
60	2-10754	Seat back – BLACK – 43 ½ x 17 ½	1
-	2-50619	#14 X 1-3/4" Pan head-Tapping screw	6
61	2-10773	Headrest – BLACK & GREY – 9 x 6 ½	2
61	2-10803	Headrest – BLACK – 9 x 6 ½	2
-	2-50085	bolt, 1/4 x 1 1/2"	4
62	2-10772	Seat bottom – BLACK & GREY – 43 ½ x 17 ½	1
62	2-10755	Seat bottom – BLACK – 43 ½ x 17 ½	1
63	2-45416	seat bar, CW (17 1/2") - black	2
-	2-50609	#14 x 3/4 pan head tapping	6
65	14786	Seatbelt, retractable without sleeve	2
-	8375	Seatbelt plastic sleeve - 7" length	2
-	2-50025	7/16 Nylock	4
70	2-18356	Dump Bed UTV Plastic	1
-	2-50255	5/8 x 4" bolt Zinc plate	2
-	2-50015	5/8 nylock	2
-	2-18413	Bed Bumper 3/8" Rubber	2
73	2-50208	Bed latch bolt, 3/8 x 2 1/2"	1
-	2-50013	nut, 3/8 keps	2
-	2-50740	washer, 3/8 flat	2
75	2-18357	Dump Bed Tailgate UTV Plastic	1
80	2-18328	Roof, Black Textured	1
-	2-18390	UTV, Top – Hardware Package	1
85	2-18411	Windshield - clear	
-	2-18407	Tube Mount, Windshield	
88	2-40729	Front reciever hitch 4x4 kit	1
-	2-50162	Bolt, 5/16 x 1-3/8 - U	4
-	2-50704	Washer, 5/16 Flat	8
-	2-50007	Nut, 5/16 Nylock	8
89	2-40536	Rear Spindle Welded assembly, Left	1
-	2-40536	Rear Spindle Welded assembly, Right	1
90	2-25021	Rear Spindle Bearing	4
101	2-20019	Engine, Subaru V-Twin 653cc	1
-	2-50202	3/8-16 x 1 3/4" Hex Hd Bolt	4
-	2-50740	3/8" Flatwasher, USS	4
102	2-20821	Dana IRS	1
103	2-20822	IRS Half-Shafts	2
103a	2-20873	CV Boot (1 per half shaft)	
-	16175	Circlip, 24.5 x 1.6	2
104	2-52018	Kit, Muffler 650	
107	2-20662	TC, Driver CV Tech	1
105	2-18151	Muffler, Mid Mount	1
-	2-50206	Bolt, 3/8 x 1 Hex Head	2
-	2-50010	Nut, 3/8 Nylock	2
-	2-50740	Washer, 3/8 Flat	4
106	2-18152	Muffler, Lower Mount	1
-	2-70251	Rubber Mounts	2
-	2-50010	Nut, 3/8 Nylock	4

NOTE: parts denoted as left or right hand are from driver's point of view.

REFERENCE NUMBER	PART NUMBER	PART DESCRIPTION	QUANTITY REQUIRED
-	2-50740	Washer, 3/8 Flat	4
107	2-20662	TC, Driver CV Tech (parts list on page 4)	1
108	2-20661	TC, Driven 10.25" CV Tech (parts list on page 5)	1
109	2-25011	8.75" Brake Rotors (rear)	2
-	2-50073	Nut, 5/8 Half Nylock	2
110	2-50745	1" I.D. Spacer Washer	4
111	2-10190	3/16 x 1/4 x 1-1/2" Keystock (for use with CV Tech driver pulley)	1
114	2-50226	Bolt, Tapered	1
115	2-20698	Belt, CV Tech Power Block	1
116	2-50239	Bolt 1/2" x 2" SAE	1
117	2-50722	1/2" Lock Washer	1
118	2-10191	3/16 x 3/16 x 3-1/4" Keystock (for use with CV Tech driven pulley)	1
-	2-50157	5/16x 3/4" Bolt Hex Hd NF	2
-	2-50703	5/16" Lock Washer	2
-	2-50704	5/16" Flatwasher	2
119	2-11124	Brake caliper (Rear) (pads not included)	2
-	2-11167	Brake pads (individual - 2 per caliper)	4
-	2-11168	Caliper Bolts	4
-	2-11169	Caliper Clips	4
-	2-11137	Banjo Bolt	2
-	2-11138	Crush Washers	4
121	2-10583	Rod End Sphcl-UTV (4681-MPM-12)	1
122	2-50021	3/4 Jam nut SAE	3
124	2-50206	bolt, 3/8 x 1	4
-	2-50010	3/8" Nylock Nut	4
-	2-50740	3/8" Flatwasher, USS	4
125	2-50730	3/4" Spacer Washer	6
126	2-50280	3/4 x 2.5 SAE bolt	3
127	2-50020	3/4 SAE nylock	3
128	2-18012	shifter lever, CW - black	1
-	2-50084	1/4-20 x 3/4" Hex Hd Bolt	2
-	2-50000	1/4" Keps Nut	4
129	2-18011	shifter cable mount, CW - black	1
131	2-11012	Throttle Cable, UTV	1
-	2-50087	1/4-20 x 1" Hex Hd Bolt	1
-	2-50000	1/4" Keps Nut	2
-	2-11804	Spring #80704	1
133	2-11804	Spring #80704	1
136	2-65500	fuel hose 3/16" dia - 24"	1
137	2-50849	hose clamps - small	3
138	2-18343	Silcar Belt Guard	1
-	2-50624	#10 x 3/4" Blunt Point Black	7
-	2-50050	#10 Speed Nut - for Plastic	7
-	2-50770	#10 Flatwasher	7
139	2-45449	Upper Control Arm (right rear)	2
-	2-45448	Upper Control Arm (left rear)	
140	2-45450	Lower Control Arm (rear)	2
-	2-51102	suspension bushings	2 ea
-	2-42114	DOM 6.78"	6
-	2-42117	DOM 3.78"	6

NOTE: parts denoted as left or right hand are from driver's point of view.

REFERENCE NUMBER	PART NUMBER	PART DESCRIPTION	QUANTITY REQUIRED
-	2-50095	Bolt, 3/8" x 5"	6
-	2-50225	Bolt, 3/8" x 8"	1
-	2-50097	Bolt, 3/8" x 8.5"	1
150	2-25004	right angle gearbox	1
-	2-10184	Key, 3/16 x 1	3
151	2-20852	Gearbox coupling (before serial # 45918)	1
-	2-20841	Gearbox coupling (after serial # 45918)	1
-	2-50163	bolt, 5/16 x 3/4" NC	2
-	2-50701	Washer, 5/16 flat	2
-	2-50703	Washer, 5/16 lock	2
152	2-18083	Gear Box Mount	1
153	2-18032	diff lock mount	1
-	2-50163	bolt, 5/16 x 3/4" NC	2
-	2-50701	Washer, 5/16 flat	2
-	2-50703	Washer, 5/16 lock	2
ADDITIONAL PARTS FOR "S" MODELS WITH STEEL BED / REAR FLIPSEAT			
-	2-45424	Steel Bed Black	1
-	2-45425	Steel Tailgate Black	1
-	2-70230	Rubber, Bumper – Dome - Large	2
-	2-55094	Flip Seat Kit-UTV	1

HEADLIGHT REPLACEMENT BULBS AND ASSEMBLIES FOR ASW UTILITY VEHICLES

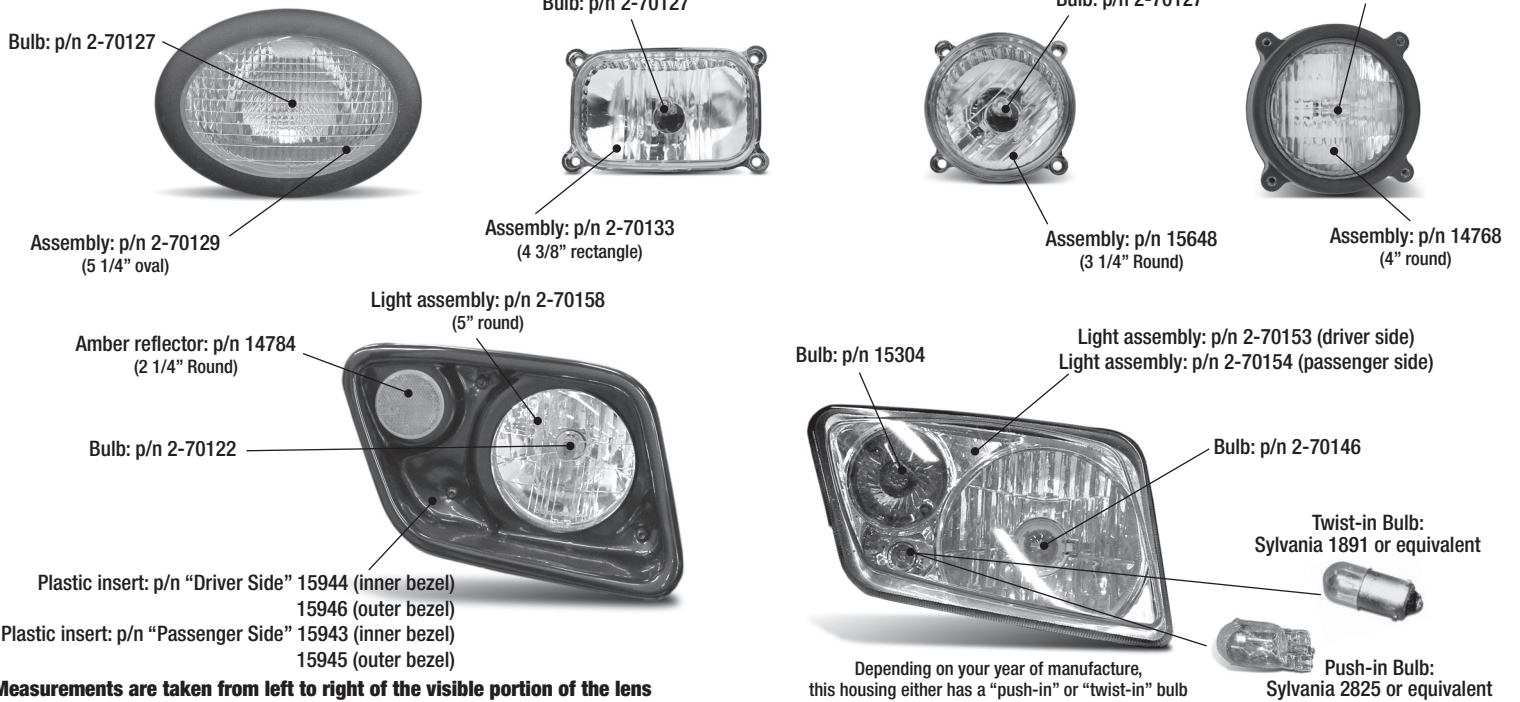

Measurements are taken from left to right of the visible portion of the lens

ORDERING PARTS

FAST & EASY!

- 1) Seek Part(s) from your models illustrated diagram, cross over REF# to PART#
- 2) Type PART# into sites [Search Box] at GoKartsRus.com TIP! - RIGHT CLICK LINK, SELECT OPEN IN NEW TAB
- 3) Add all needed parts to Shopping Cart | Complete "Checkout" | ✓ Done!

If a part does not come up in a Site Search, please [Contact Us](#) (include part# in email)

LOWEST PRICE!