



**AMERICAN  
SPORTWORKS®**

## 200 SERIES LUTV

WITH 150cc ENGINE

### ORDERING PARTS

**FAST & EASY!**

- 1) Seek Part(s) from your models illustrated diagram, cross over REF# to PART#
- 2) Type PART# into sites [Search Box] at [GoKartsRus.com](http://GoKartsRus.com) TIP! - RIGHT CLICK LINK, SELECT OPEN IN NEW TAB
- 3) Add all needed parts to Shopping Cart | Complete "Checkout" | ✓ Done!

*If a part does not come up in a Site Search, please [Contact Us](#) (include part# in email)*

**LOWEST PRICES!**



**150CC 2 WHEEL DRIVE LIGHT UTILITY VEHICLE**

**ILLUSTRATED PARTS LIST**

# TABLE OF CONTENTS

<b>SECTION 1 CYLINDER HEAD ASSEMBLY</b> .....	1
<b>SECTION 2 CYLINDER</b> .....	2
<b>SECTION 3 ENGINE CRANKCASE</b> .....	3
<b>SECTION 4 TRANSMISSION</b> .....	4
<b>SECTION 5 CVT COVER</b> .....	5
<b>SECTION 6 OUTER CRANKCASE ASSEMBLY</b> .....	6
<b>SECTION 7 PISTON / CRANK / CONNECTING ROD</b> .....	7
<b>SECTION 8 CAMSHAFT ASSEMBLY</b> .....	8
<b>SECTION 9 OIL PUMP ASSEMBLY</b> .....	9
<b>SECTION 10 DRIVEN PULLEY &amp; CLUTCH</b> .....	10
<b>SECTION 11 ENGINE ELECTRICAL</b> .....	11
<b>SECTION 12 ELECTRIC START</b> .....	12
<b>SECTION 13 DRIVER PULLEY</b> .....	13
<b>SECTION 14 OIL COOLER</b> .....	14
<b>SECTION 15 FAN COVER / SHROUD ASSEMBLY</b> .....	15
<b>SECTION 16 CARBURETOR</b> .....	16
<b>SECTION 17 FRAME GROUP</b> .....	17,19
<b>SECTION 18 STEERING &amp; BRAKES</b> .....	20
<b>SECTION 19 FRONT SUSPENSION</b> .....	21
<b>SECTION 20 BED / TAILGATE</b> .....	22
<b>SECTION 21 UPPER SWINGARM ASSEMBLY</b> .....	23
<b>SECTION 22 ENGINE / MUFFLER / AIR CLEANER</b> .....	24
<b>SECTION 23 LOWER SWINGARM ASSEMBLY</b> .....	25
<b>SECTION 24 REAR AXLE</b> .....	26
<b>SECTION 25 ELECTRICAL</b> .....	27
<b>SECTION 26 WARNING LABELS</b> .....	28

# 200 SERIES LUTV SECTION 1 CYLINDER HEAD ASSEMBLY

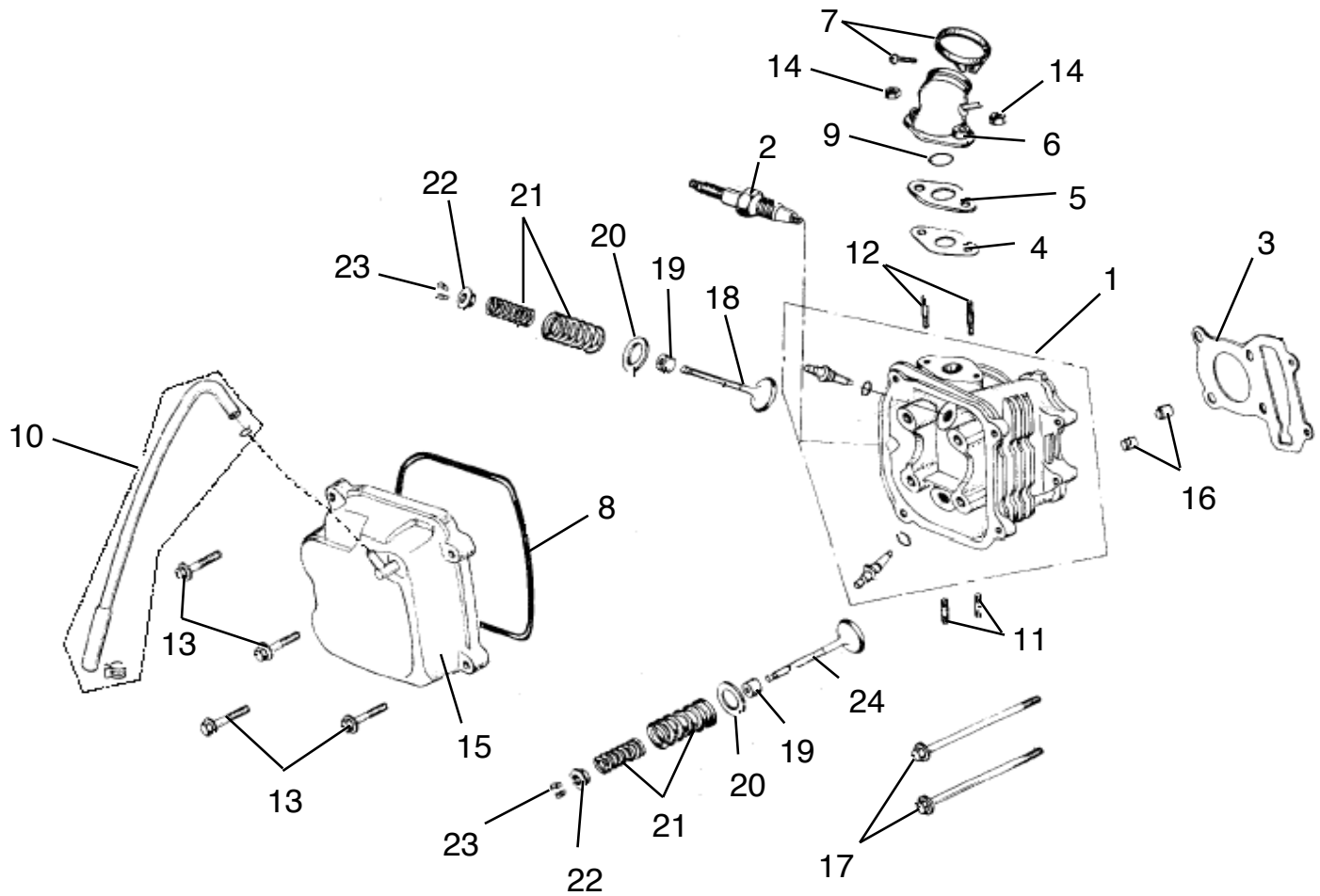

Ref#	Part#	Description	Qty
1	14254	HEAD, CYLINDER - 150CC	1
2	50304	SPARK PLUG (CR7HSA)	1
3	14255	GASKET, CYL HEAD - 150CC	1
4	14256	GASKET, CARB INSULATOR - 150CC	1
5	14257	INSULATOR, CARB - 150CC	1
6	14258	MANIFOLD, INTAKE - 150CC	1
7	14259	CLAMP, CARB HOSE - 150CC	1
8	14260	GASKET, VALVE COVER - 150CC	1
9	14261	O-RING, M27 X 2 RUBBER - 150CC	1
10	14262	TUBE, BREATHER - 150CC	1
11	14263	STUD, M6 X 1.25 X 18	2
12	14264	STUD, M6 X 1.25 X 50	2

Ref#	Part#	Description	Qty
13	50003	BOLT, M6 x 1.00 x 25 HHF	4
14	50024	NUT, M6 x 1.00 HEX FLANGE	2
15	14265	COVER, VALVE - 150CC	1
16	14266	PIN, M10 X 16 DOWEL	2
17	50087	BOLT FLANGE SH 6 X 100	2
18	14267	VALVE, INTAKE - 150CC	1
19	14268	SEAL, VALVE STEM - 150CC	2
20	14269	SEAT, VALVE SPRING OUTER - 150CC	2
21	14270	SPRING, OUTER AND INNER VALVE - 150CC	2
22	14271	RETAINER, VALVE SPRING - 150CC	2
23	14272	KEEPER, VALVE SPRING - 150CC	4
24	14273	VALVE, EXHAUST - 150CC	1

NOTE: parts denoted as left or right hand are from driver's point of view.

# 200 SERIES LUTV SECTION 2 CYLINDER

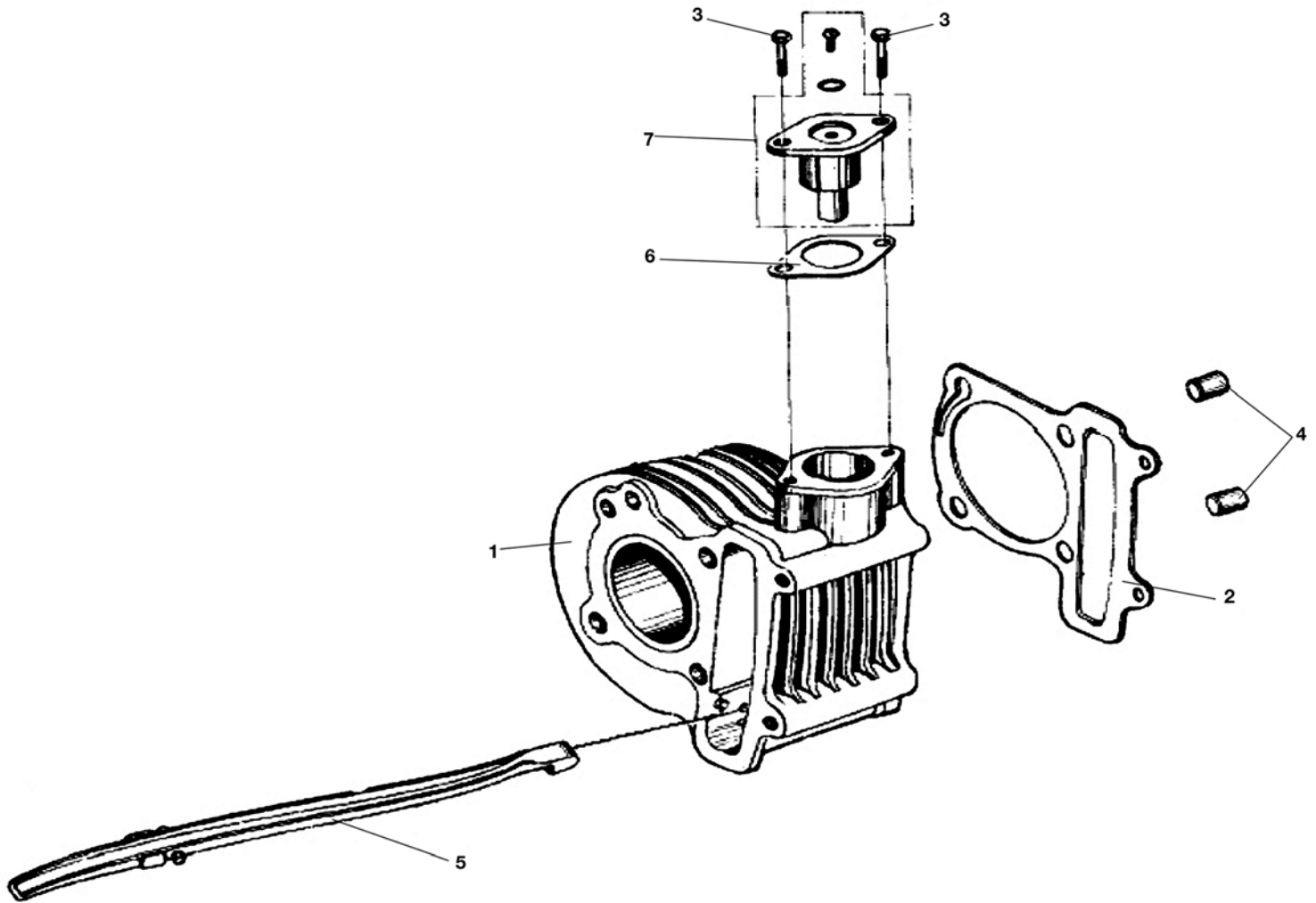

Ref #	Part #	Description	Qty
1	14317	CYLINDER - 150CC	1
2	14582	GASKET, CYLINDER BASE - 150CC	1
3	50032	BOLT FLANGE SH 6 X 22	2
4	14266	PIN, M10 X 16 DOWEL	2
5	14276	TENSIONER, CAM CHAIN - 150CC	1
6	14275	GASKET, CAM CHAIN TENSIONER - 150CC	1
7	14274	ASM, CAM CHAIN TENSIONER - 150CC	1

NOTE: parts denoted as left or right hand are from driver's point of view.

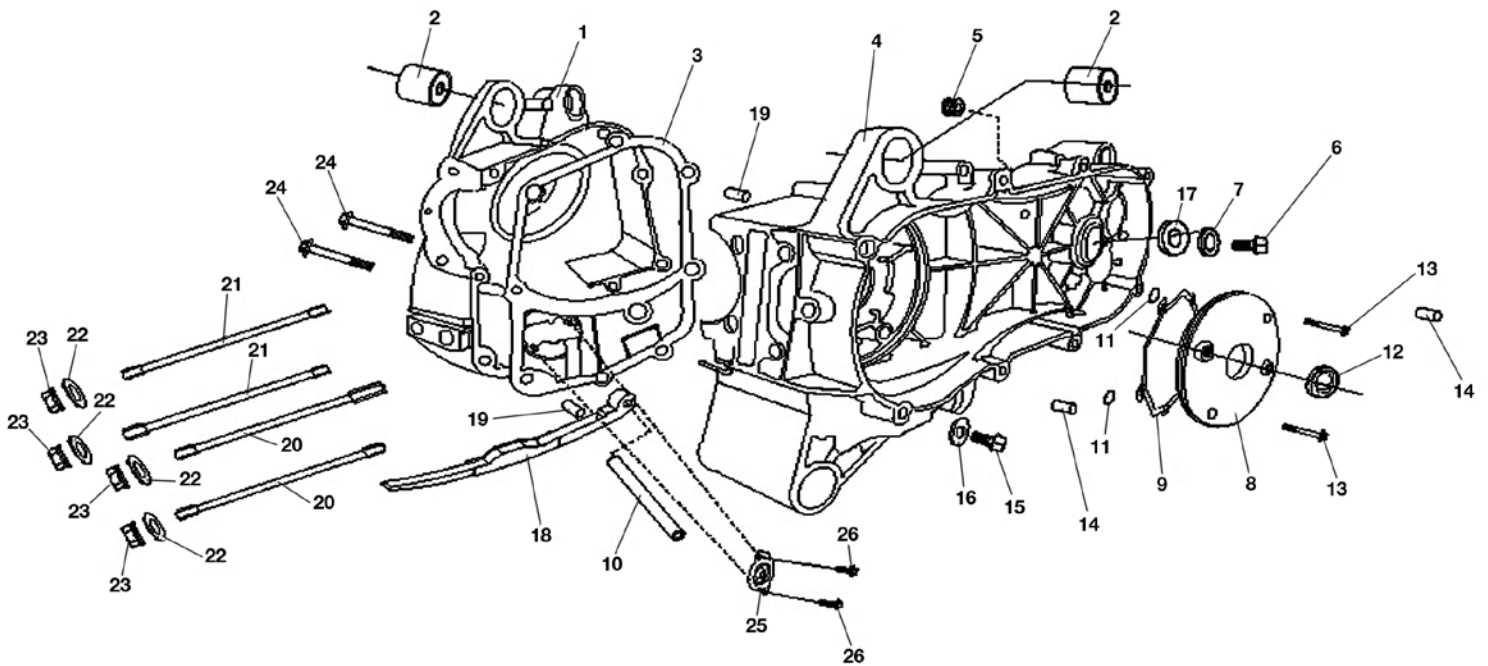

\* ASW determined that it is more cost effective due to labor to replace the entire engine if this part is needed. Once this determination was made, ASW stopped ordering this part as a replacement item and are now sold out.

Ref#	Part#	Description	Qty
1	14277	(OUT OF STOCK)* HOUSING, CRANKCASE RH	1
2	14278	BUSHING, ENGINE HANGER - 150CC	2
3	14279	GASKET, CRANKCASE - 150CC	1
4	14280	HOUSING, CRANKCASE LH - 150CC	1
5	14558	GROMMET	1
6	14281	BOLT, M10 X 1.25 X 15 FHCS ZN	1
7	14282	WASHER, M10.2 X 18 X 1.3 FLAT	1
8	14283	COVER, SMALL LEFT - 150CC	1
9	14284	O-RING, M108 X 2	1
10	14559	PIN	1
11	14285	O-RING, M6 X 1.8	2
12	50104	OIL SEAL 19.8 X 30 X 5	1
13	14286	BOLT, M6 X 1.00 X 18 FHCS ZN	4

Ref#	Part#	Description	Qty
14	14287	PIN, M10 X 14 DOWEL	2
15	14288	BOLT, M12 X 1.5 SPECIAL - 150CC	1
16	14690	WASHER, M12 DAC	2
17	14290	SEAL, M20 X 32 X 6	2
18	14883	GUIDE, CAM CHAIN - 150CC	1
19	50016	PIN DOWEL SPECIAL 8 X 14	2
20	14291	STUD, M8 X 1.25 X 195.5	2
21	14292	STUD, M8 X 1.25 X 187.5	2
22	14293	WASHER, M8 FLAT ZN	4
23	14294	NUT, M8 X 1.25 FLANGE HEAD	4
24	14295	BOLT, M6 X 1.00 X 50 FHCS ZN	2
25	14501	SPACER, OIL - 150CC	1
26	14296	BOLT, M6 X 1.00 X 12 FHCS ZN	2

**NOTE:** parts denoted as left or right hand are from driver's point of view.

# 200 SERIES LUTV SECTION 4 TRANSMISSION

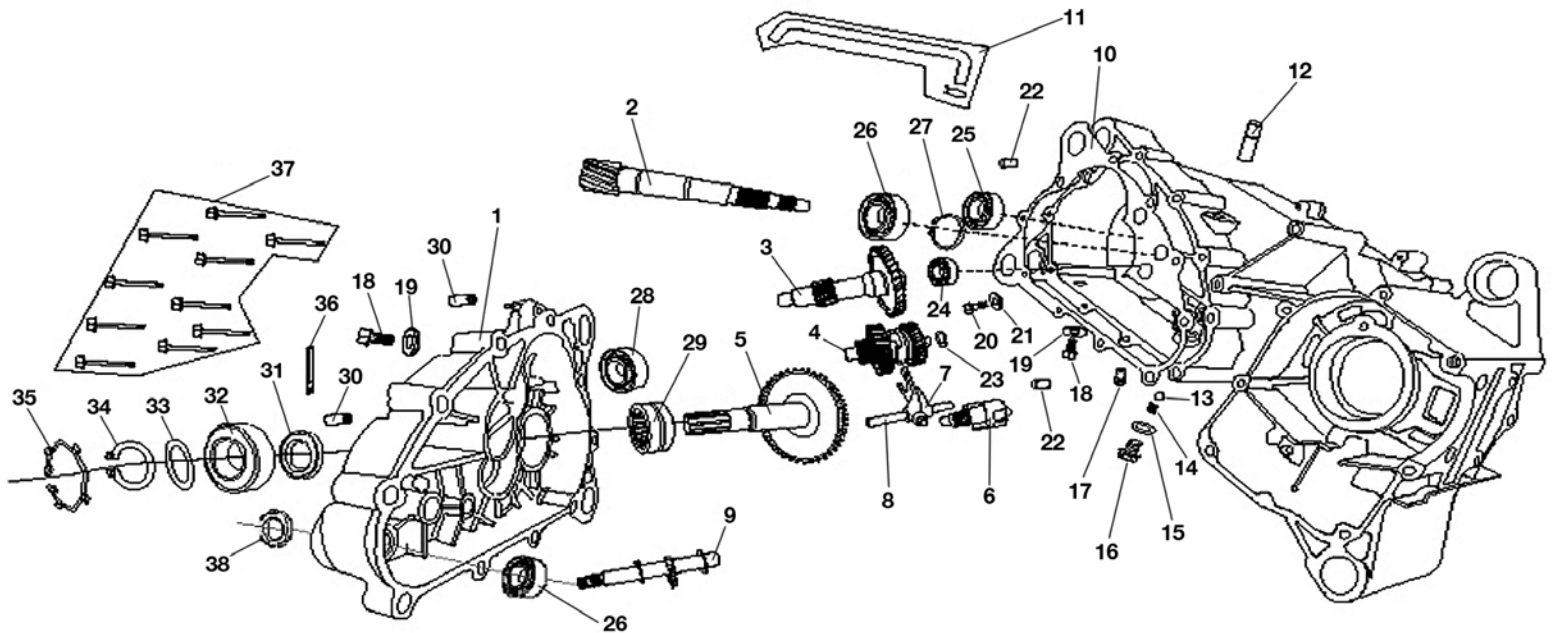

Ref#	Part#	Description	Qty
1	14297	HOUSING, OUTER TRANSMISSION - 150CC	1
2	14298	GEAR, PRI DRIVE - 150CC	1
3	14299	GEAR, SEC DRIVE - 150CC	1
4	14300	ASM, SHIFT GEAR CLUSTER D/N/R - 150CC	1
5	14841	GEAR, FINAL DRIVE SHAFT - 150CC	1
6	14302	ASM, SHIFT SELECTOR - 150CC	1
7	14303	PAWL, SHIFT SELECTOR - 150CC	1
8	14304	ROD, SHIFT PAWL - 150CC	1
9	14305	SHAFT, SHIFTER CAM - 150CC	1
10	14306	GASKET, TRANSMISSION CASE - 150CC	1
11	14307	TUBE, TRANSMISSION VENT - 150CC	1
12	14308	NIPPLE, VENT TUBE - 150CC LARGE	1
13	14309	BALL, SHIFT INDENT - 150CC	1
14	14310	SPRING, SHIFT INDENT - 150CC	1
15	14311	GASKET, SHIFT INDENT - 150CC	1
16	14312	BOLT, SHIFT INDENT - 150CC	1
17	14502	NIPPLE, VENT TUBE - 150CC SMALL	1
18	14313	BOLT, DRAIN/FILL PLUG - 150CC	2
19	14314	GASKET, TRANS DRAIN PLUG - 150CC	2

Ref#	Part#	Description	Qty
20	14296	BOLT, M6 X 1.00 X 12 FHCS ZN	2
21	14315	WASHER, M6 FLAT	2
22	14287	PIN, M10 X 14 DOWEL	2
23	14316	SPACER, M15 INNER GEAR - 150CC	1
24	14149	BEARING, OUTER - 6202-Z	1
25	50102	BEARING BALL RADIAL 6203	1
26	14146	BEARING, INNER - 6204-Z	1
27	14106	CIRCLIP, M20	1
28	14503	BEARING, 6302 15 X 42 X 13	1
29	14504	BEARING, RNA4905 30 X 42 X 17	1
30	14505	BUSHING, SHOCK ABSORBING - 150CC	2
31	14318	SEAL, M30 X 40 X 6	1
32	14598	BEARING, SEALED 6205 - 150CC	1
33	14511	WASHER, M22 X 31 X 2.5 FLAT	1
34	14319	CIRCLIP, M25	1
35	14320	CIRCLIP, M52	1
36	14321	CLAMP, WIRE - 150CC	1
37	14235	BOLT, M6 X 1.00 X 40 FHCS ZN	10
38	14597	OIL SEAL, SHIFTER CAM - 150CC	1

NOTE: parts denoted as left or right hand are from driver's point of view.

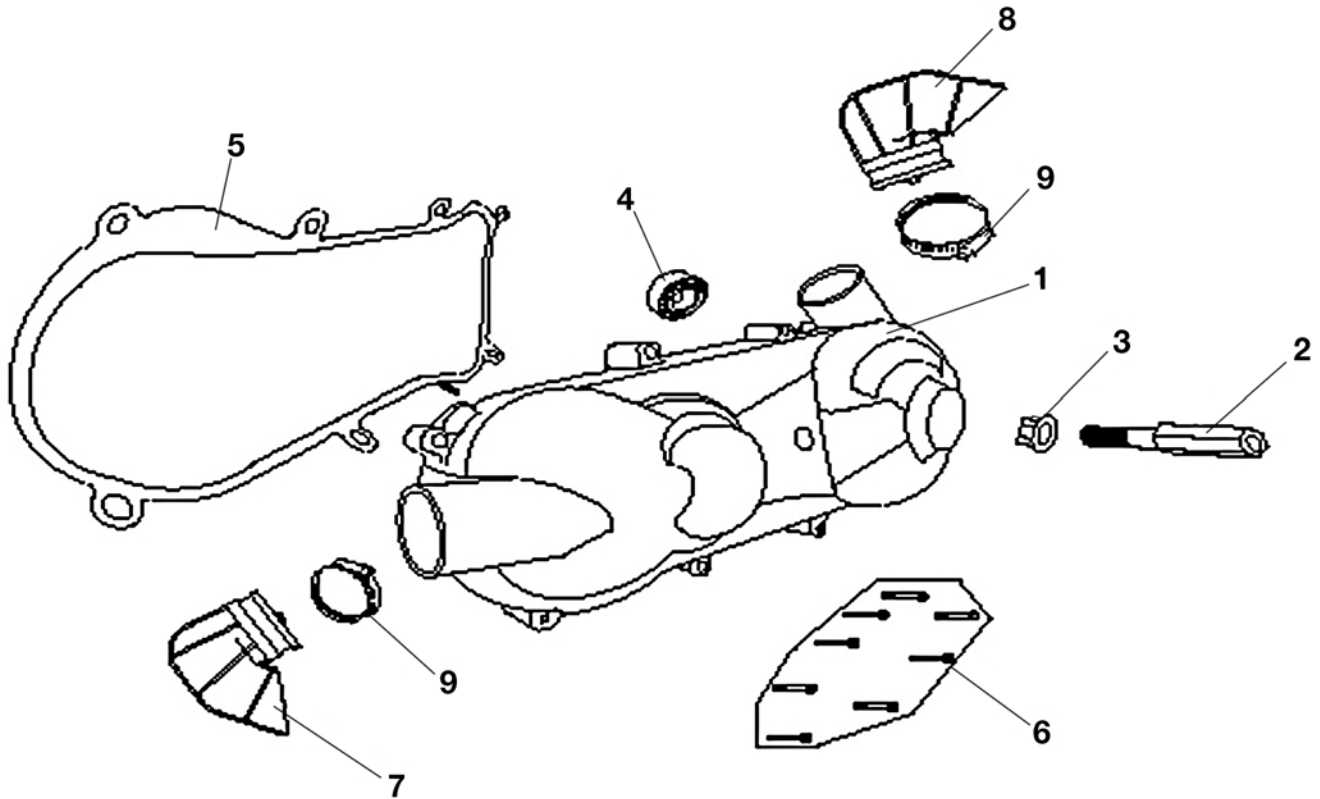

Ref#	Part#	Description	Qty
1	14323	COVER, CVT - 150CC	1
2	14507	BRACKET, EXHAUST - 150CC	1
3	14324	NUT, M12 X 1.25 LOCKING FLANGE ZN	1
4	14508	BEARING, 6200 10 X 30 X 9	2
5	14325	GASKET, CVT COVER - 150CC	1
6	14235	BOLT, M6 X 1.00 X 40 FHCS ZN	8
7	14322	SNORKEL, CVT - 150CC	1
8	14322	SNORKEL, CVT - 150CC	1
9	14509	CLAMP, SNORKEL - 150CC	2

**NOTE:** parts denoted as left or right hand are from driver's point of view.

# 200 SERIES LUTV SECTION 6 OUTER CRANKCASE ASSEMBLY

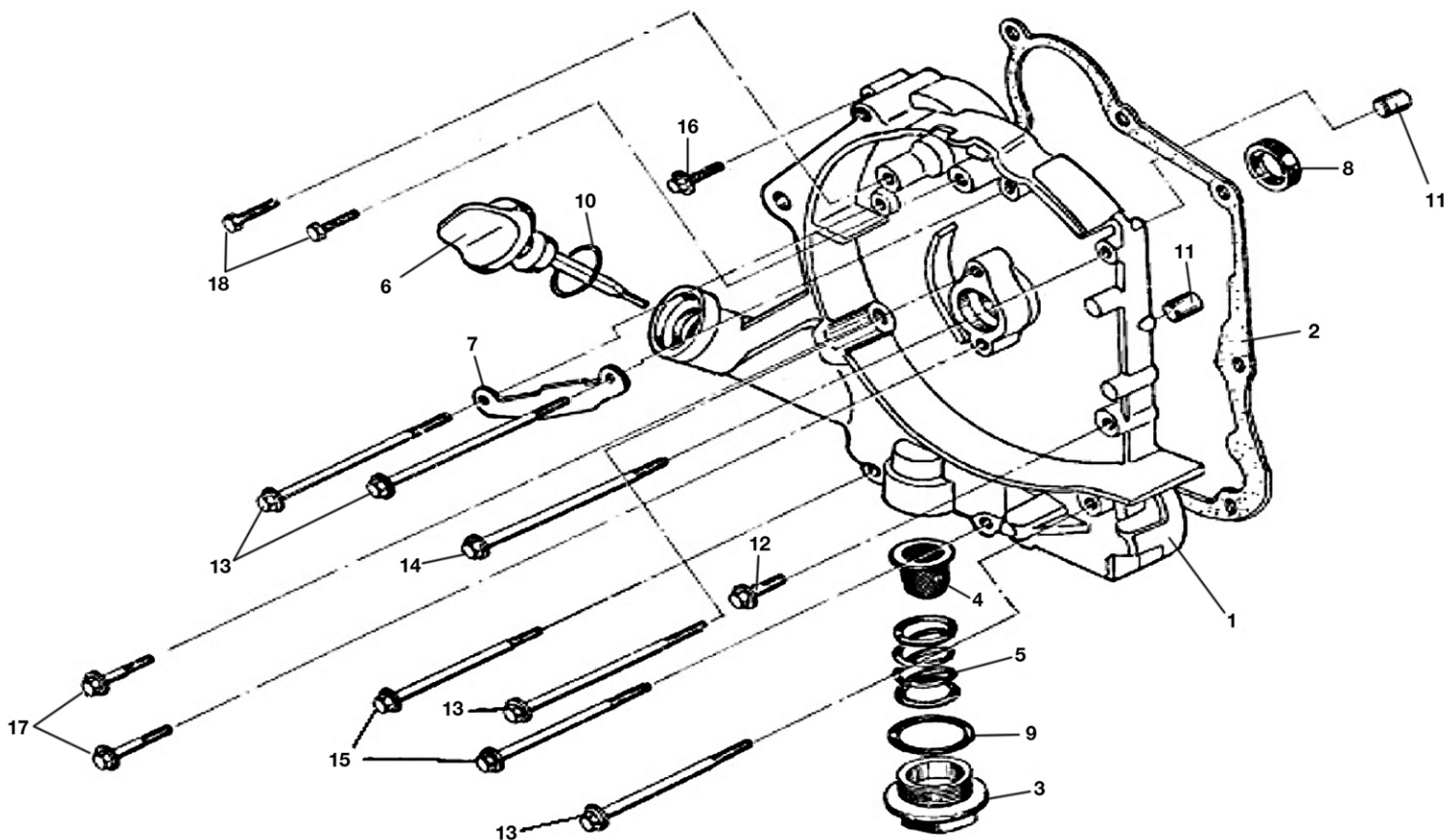

Ref#	Part#	Description	Qty
1	14326	COVER, OUTER CRANKCASE RH - 150CC	1
2	14327	GASKET, OUTER CRANKCASE - 150CC	1
3	14328	CAP, OIL DRAIN - 150CC	1
4	14329	SCREEN, OIL FILTER - 150CC	1
5	14330	SPRING, OIL FILTER SCREEN - 150CC	1
6	14331	DIPSTICK, OIL FILL - 150CC	1
7	14332	CLAMP, AC GENERATOR - 150CC	1
8	14333	SEAL, M19.8 X 30 X 5 OIL	1
9	14334	O-RING, M30.8 X 3	1
10	14335	O-RING, M18 X 3	1
11	50016	PIN DOWEL SPECIAL 8 X 14	2
12	14336	BOLT, M6 X 1.00 X 28 FHCS ZN	1
13	14337	BOLT, M6 X 1.00 X 95 FHCS ZN	4
14	14338	BOLT, M6 X 1.00 X 100 FHCS ZN	1
15	14339	BOLT, M6 X 1.00 X 110 FHCS ZN	2
16	14340	BOLT, M6 X 1.00 X 35 FHCS ZN	1
17	14341	BOLT, M6 X 1.00 X 20 FHCS ZN	2
18	14296	BOLT, M6 X 1.00 X 12 FHCS ZN	2

NOTE: parts denoted as left or right hand are from driver's point of view.



# 200 SERIES LUTV SECTION 7 PISTON, CRANK AND CONNECTING ROD

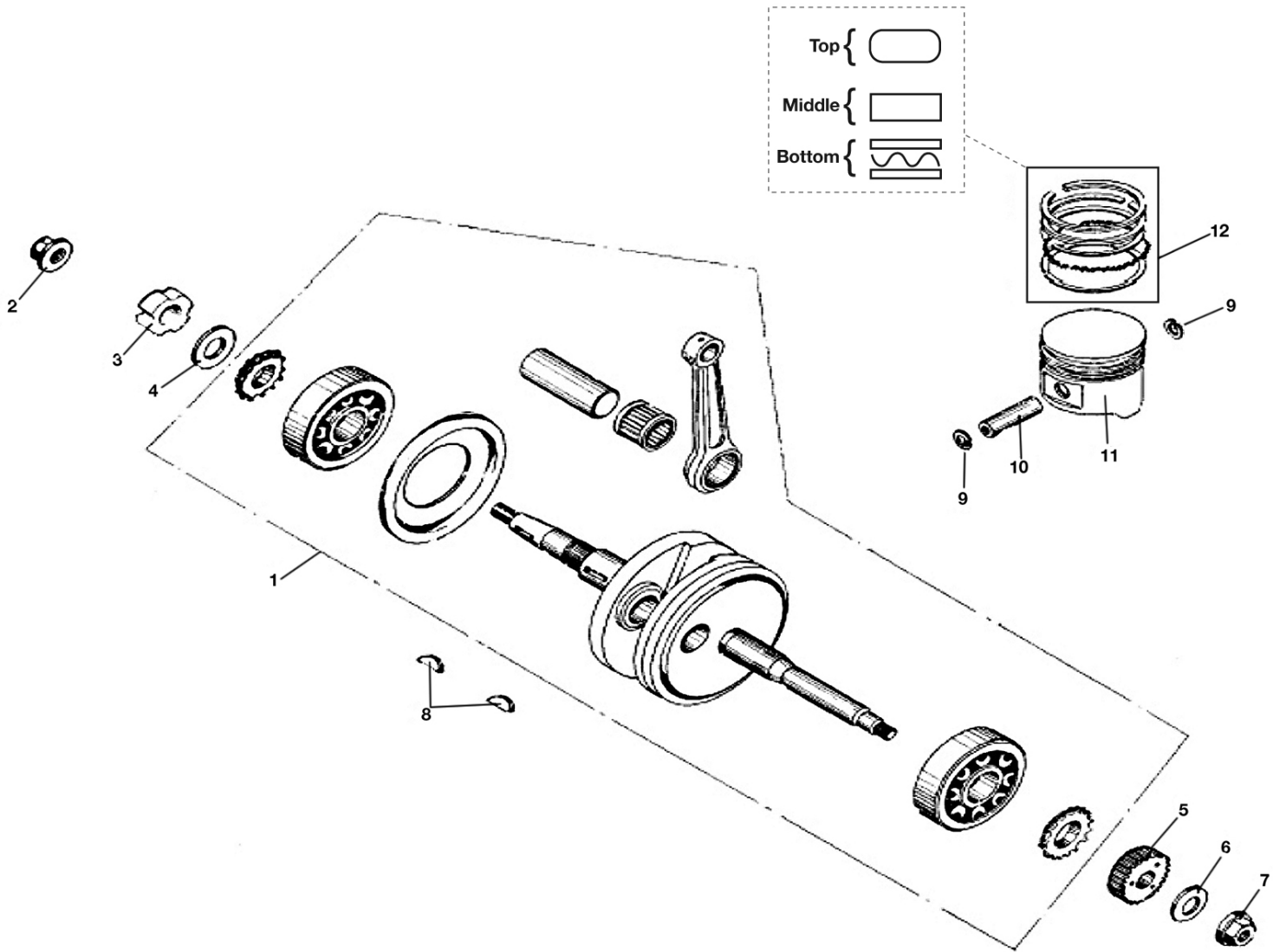

Ref#	Part#	Description	Qty
1	N/A	ASM, CRANK - CONNECTING ROD - 150CC	1
2	14324	NUT, M12 X 1.25 LOCKING FLANGE ZN	1
3	14510	NUT, M22 X 1.00 SPANNING - 150CC	1
4	14511	WASHER, M22 X 31 X 2.5 FLAT	1
5	14344	GEAR, KICK DRIVE - 150CC	1
6	14690	WASHER, M12 DAC	1
7	14324	NUT, M12 X 1.25 LOCKING FLANGE ZN	1
8	14512	KEY, WOODRUFF M4 X 14	1
9	14345	CLIP, PISTON RETAINING - 150CC	2
10	14346	PIN, PISTON WRIST - 150CC	1
11	14347	PISTON - 150CC	1
12	14348	KIT, PISTON RING - 150CC	1

**NOTE:** parts denoted as left or right hand are from driver's point of view.

# 200 SERIES LUTV SECTION 8 CAMSHAFT ASSEMBLY

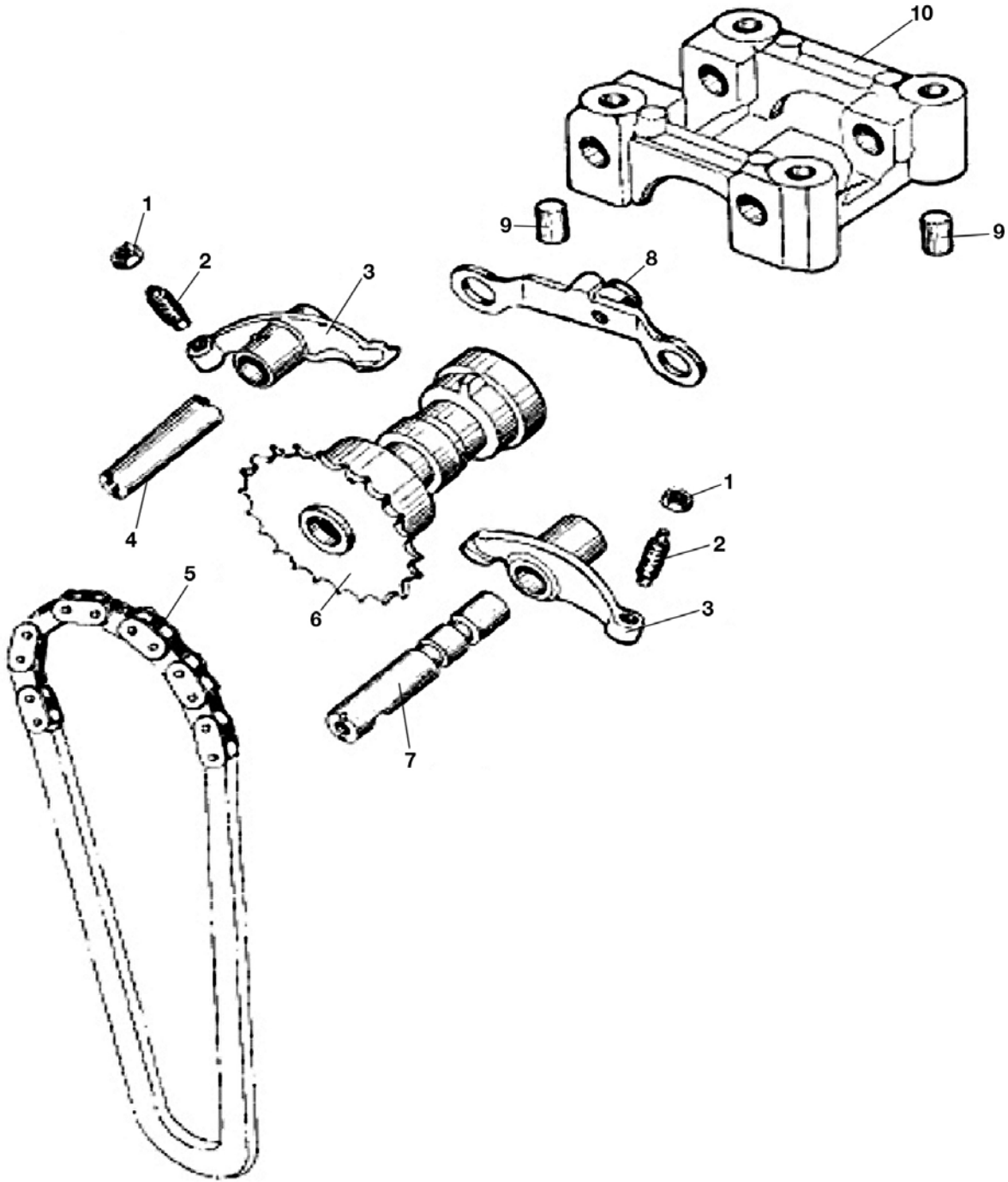

Ref#	Part#	Description	Qty
1	14513	NUT, M5 X 0.5 HEX	2
2	14349	SCREW, TAPPET ADJ - 150CC	2
3	14350	ARM, VALVE ROCKER - 150CC	2
4	14351	SHAFT, EXHAUST ROCKER ARM - 150CC	1
5	14352	CHAIN, CAMSHAFT - 150CC	1
6	14353	CAMSHAFT - 150CC	1
7	14354	SHAFT, INTAKE ROCKER ARM - 150CC	1
8	14355	PLATE, STOP - 150CC	1
9	14266	PIN, M10 X 16 DOWEL	2
10	14356	CAP, CAMSHAFT BRG - 150CC	1

**NOTE:** parts denoted as left or right hand are from driver's point of view.

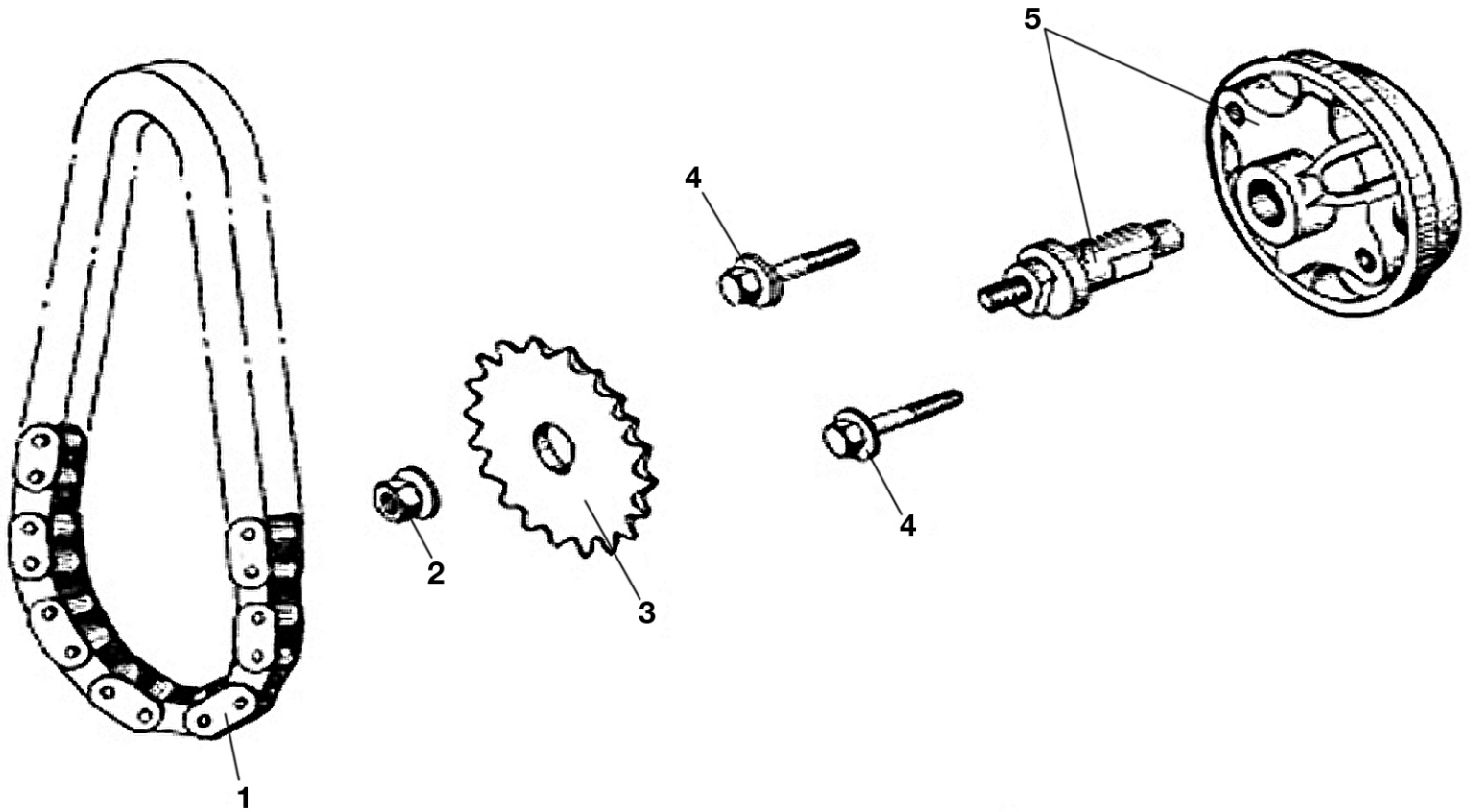

Ref#	Part#	Description	Qty
1	14357	CHAIN, OIL PUMP - 150CC	1
2	14358	NUT, M6 X 1.00 HEX FLANGE	1
3	14359	SPROCKET, OIL PUMP - 150CC	1
4	14360	BOLT, M6 X 1.00 X 30 FHCS ZN	2
5	14361	ASM, OIL PUMP - 150CC	1

**NOTE:** parts denoted as left or right hand are from driver's point of view.

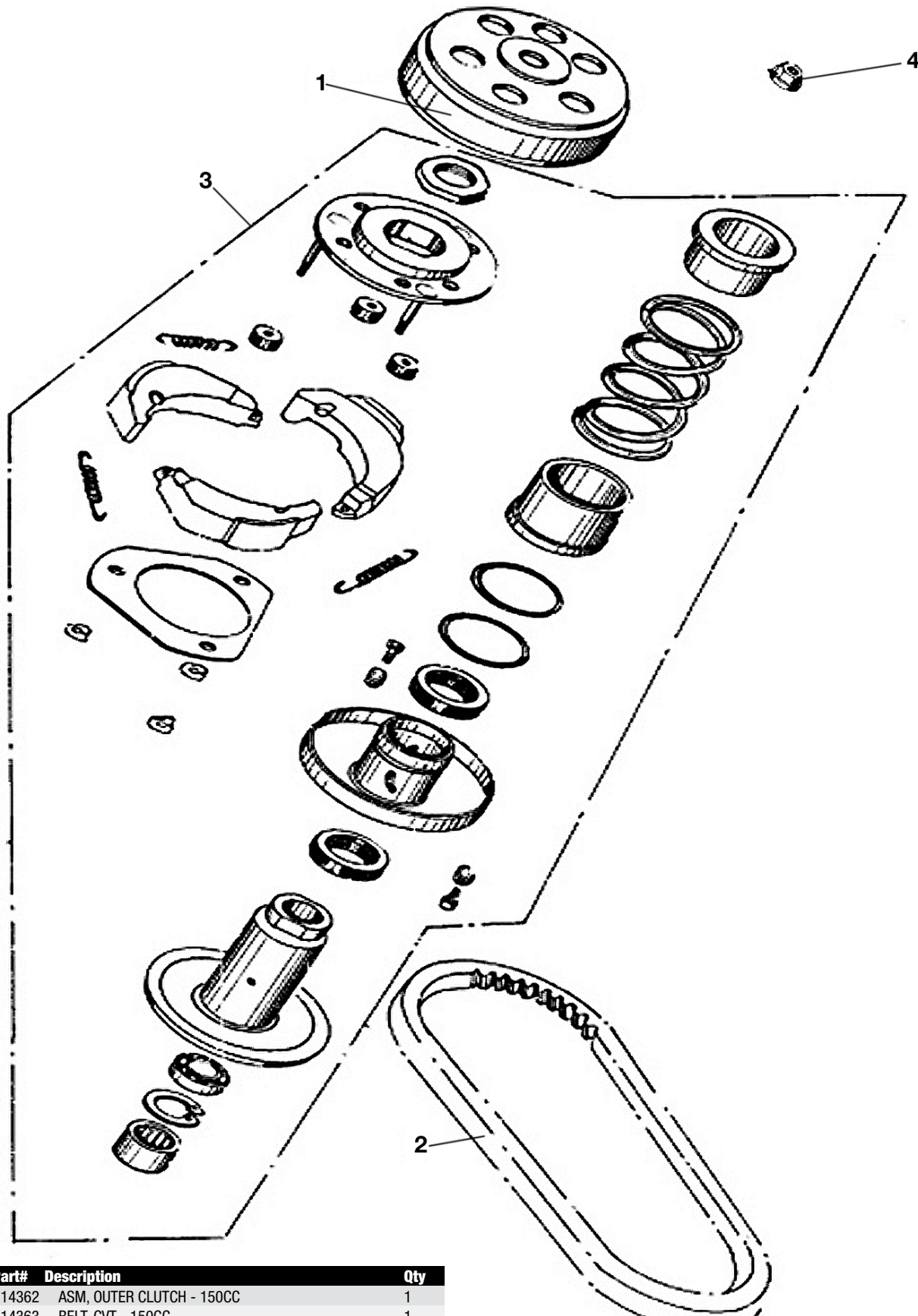

Ref#	Part#	Description	Qty
1	14362	ASM, OUTER CLUTCH - 150CC	1
2	14363	BELT, CVT - 150CC	1
3	14364	ASM, DRIVEN PULLEY - 150CC	1
4	15164	NUT, M12X1.25 LF THIN	1

NOTE: parts denoted as left or right hand are from driver's point of view.

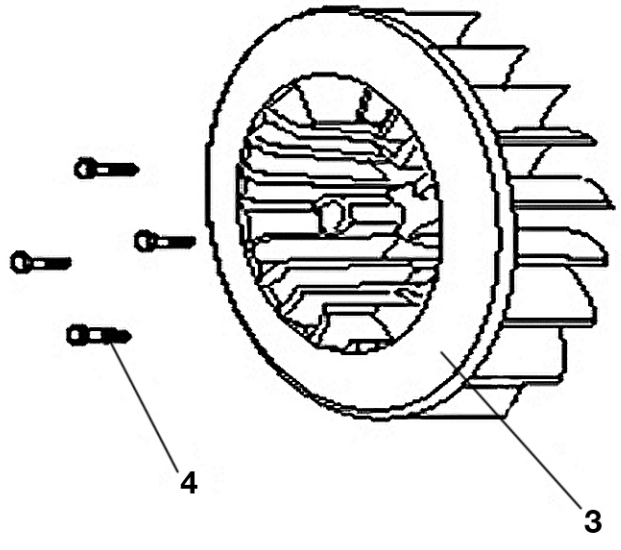
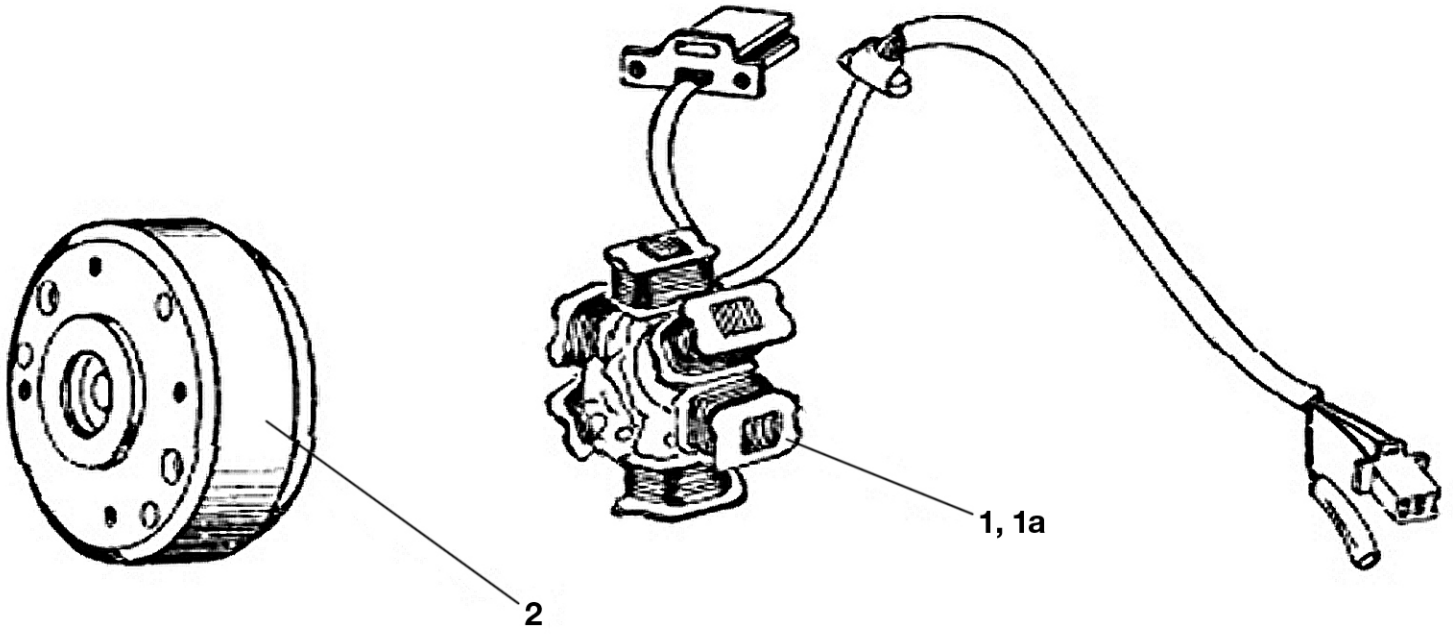

\* 2011 and newer models

Ref#	Part#	Description	Qty
1	14365	MAGNETO - 150CC	1
*1a	15120	MAGNETO, 150CC HO	1
2	14366	FLYWHEEL - 150CC	1
3	14367	FAN, COOLING - 150CC	1
4	14368	BOLT, M6 X 1.00 X 15 FHCS ZN	4

**NOTE:** parts denoted as left or right hand are from driver's point of view.

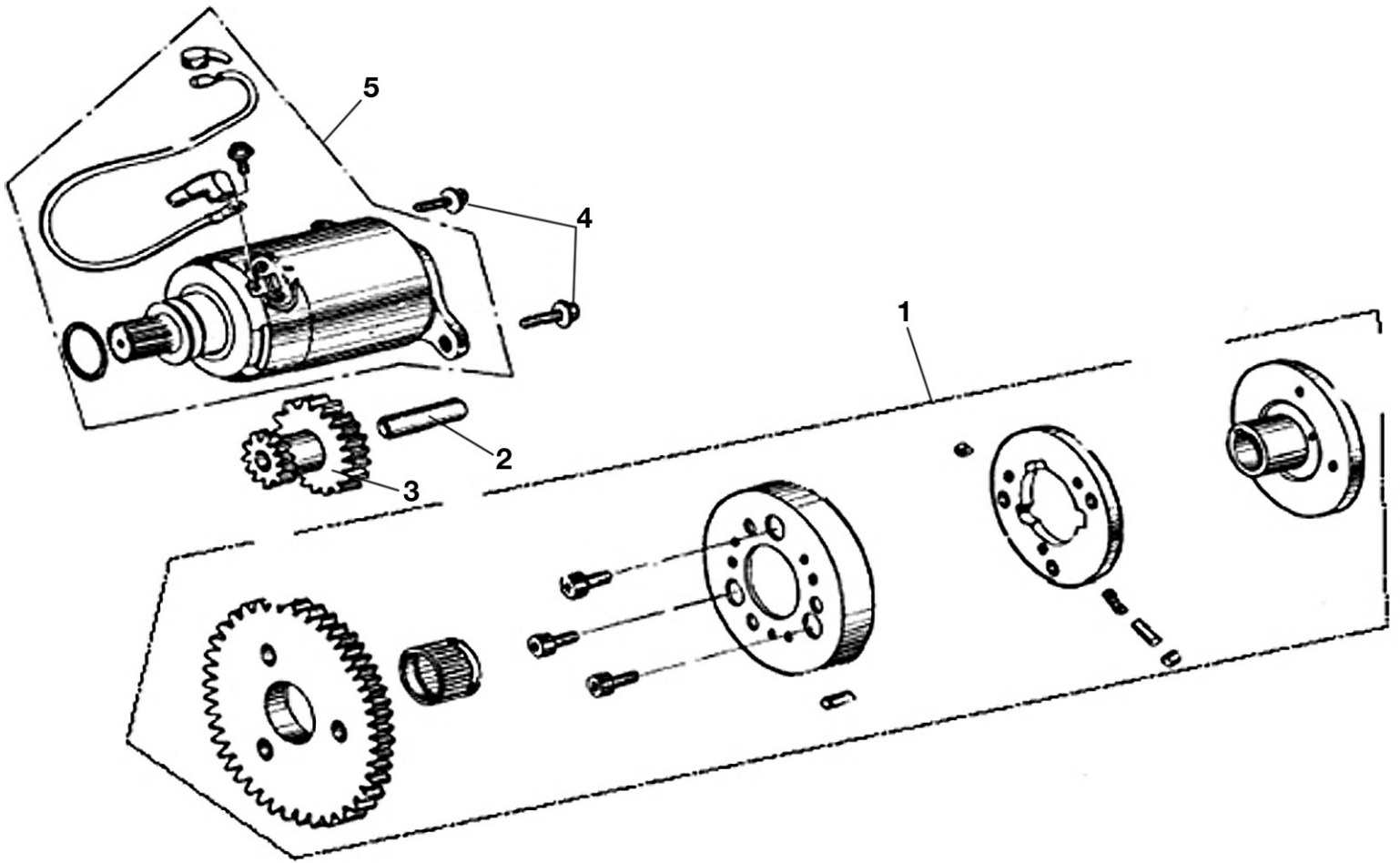

Ref#	Part#	Description	Qty
1	14369	ASM, STARTER CLUTCH - 150CC	1
2	14370	SHAFT, STARTER RED - 150CC	1
3	14371	GEAR, STARTER RED - 150CC	1
4	14372	BOLT, M6 X 1.00 X 16 FHCS ZN	2
5	14373	ASM, STARTER MOTOR - 150CC	1

**NOTE:** parts denoted as left or right hand are from driver's point of view.

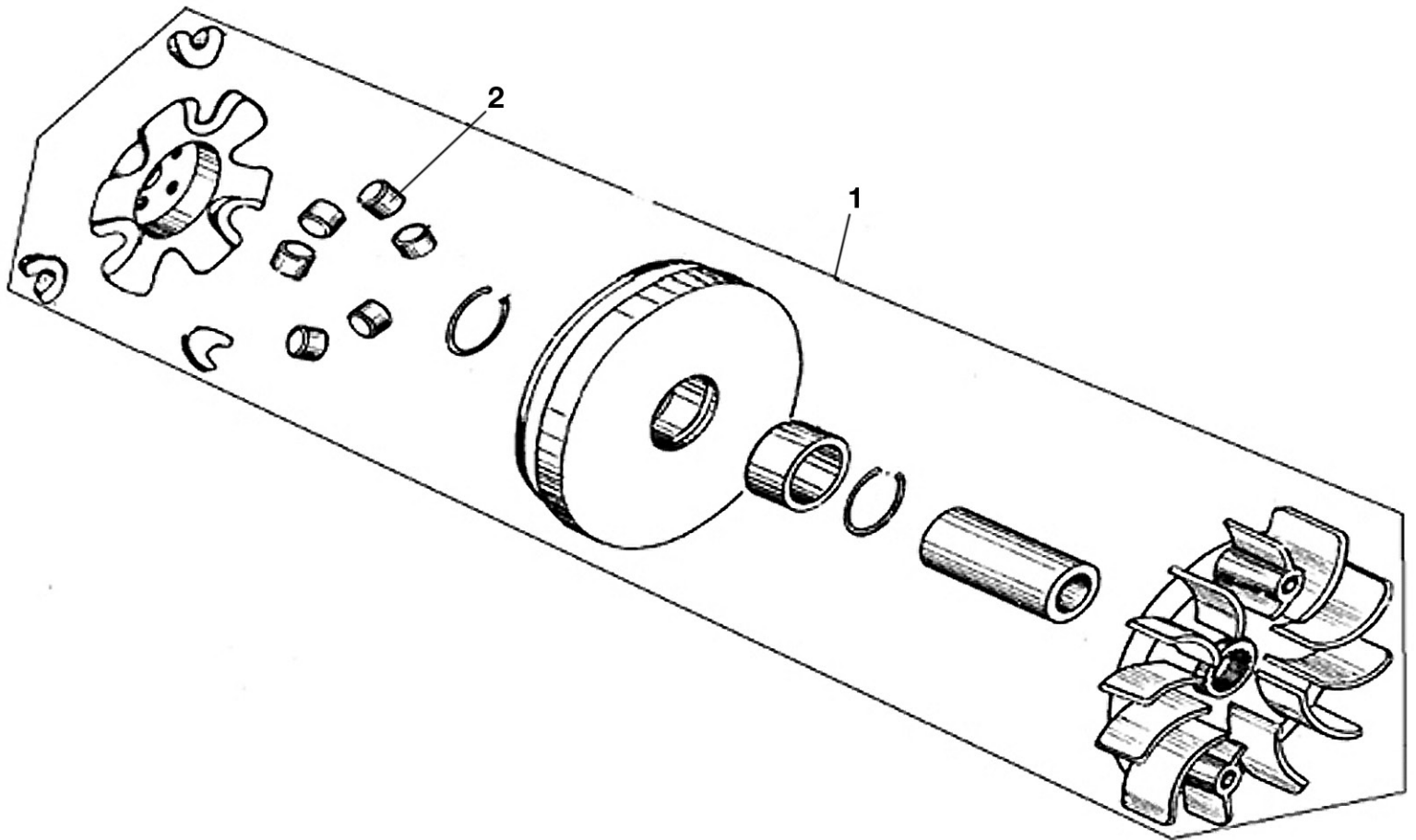

Ref#	Part#	Description	Qty
1	14374	ASM, DRIVER PULLEY - 150CC	1
2	14375	WEIGHT, DRIVER PULLEY - 150CC	6

**NOTE:** parts denoted as left or right hand are from driver's point of view.

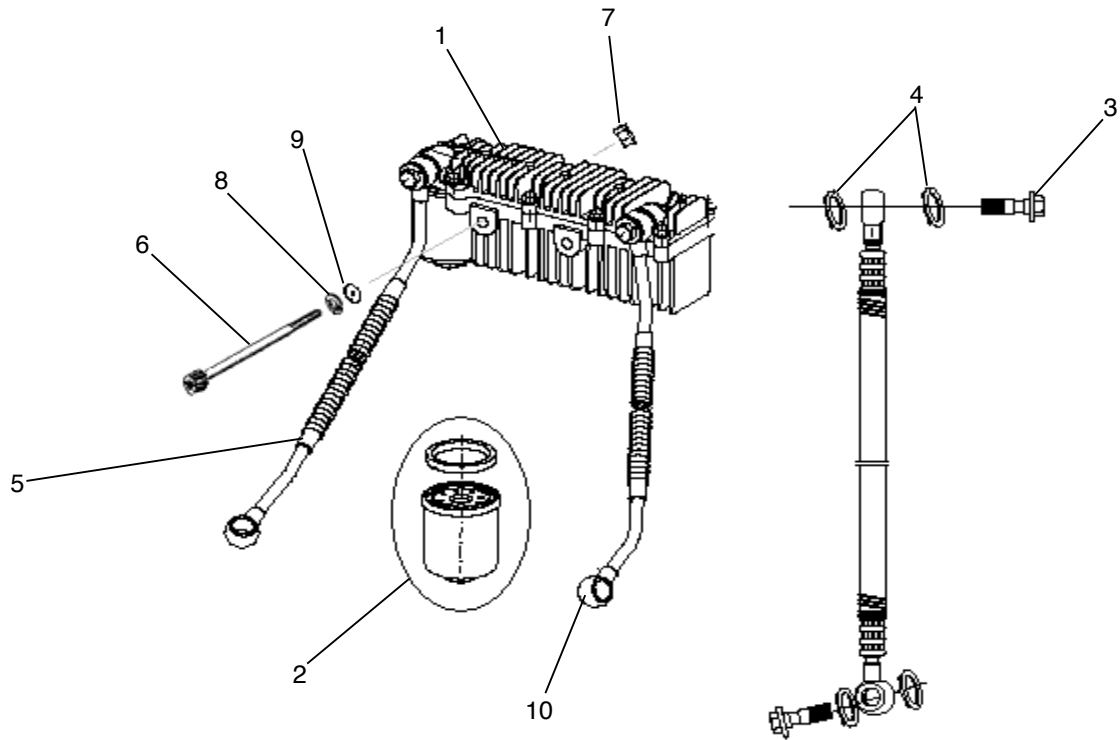

Ref#	Part#	Description	Qty
1	14376	MANIFOLD, OIL COOLER-150CC, W/ FILTER (For units with placement just behind seat)	1
2	14514	FILTER, OIL - 150CC (SEAL INCLUDED)	1
3	14537	BOLT, M12 X 28 BANJO	4
4	14538	WASHER, OIL LINE - 150CC	8
5	14599	HOSE, OIL COOLING - 150CC (540MM)	1
6	14747	BOLT, M8 X 1.25 X 75	2
7	14088	NUT, M8 X 1.25 LOCKING FLANGE ZN	2
8	14748	WASHER, M8 SPLIT LOCK	2
9	14293	WASHER, M8 FLAT ZN	2
10	14515	HOSE, OIL COOLING - 150CC (400MM)	1

**NOTE:** parts denoted as left or right hand are from driver's point of view.



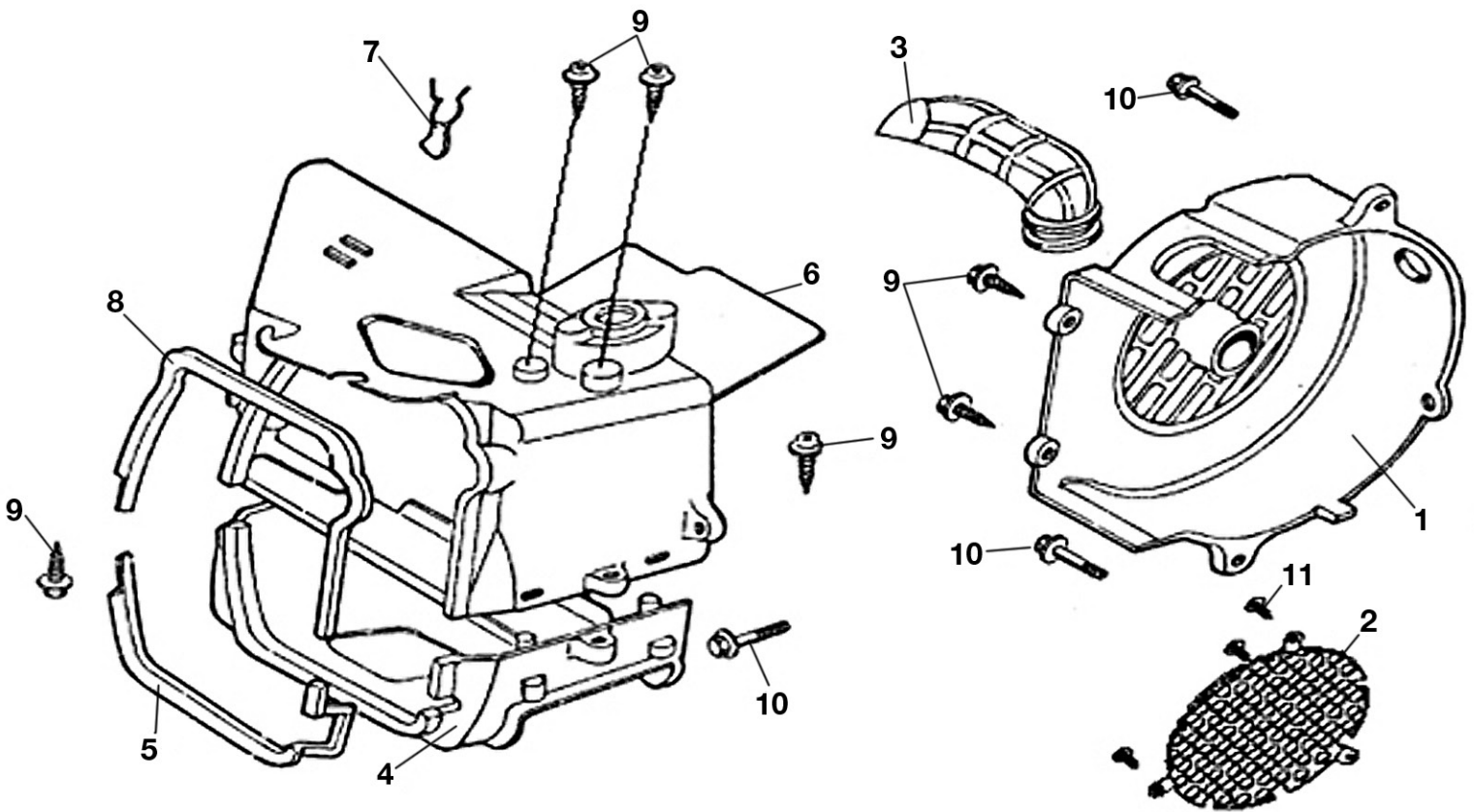

Ref#	Part#	Description	Qty
1	14540	COVER, FAN COMP - 150CC	1
2	14541	COVER, DUST - 150CC	1
3	14542	DUCT, CARBURETOR COOLING - 150CC	1
4	14543	SHROUD, LOWER - 150CC	1
5	14544	SEAL, LOWER SHROUD - 150CC	1
6	14545	SHROUD, UPPER - 150CC	1
7	14546	CLIP, CORD - 150CC	1
8	14547	SEAL, UPPER SHROUD - 150CC	1
9	50065	SCREW TAPPING	6
10	14286	BOLT FLANGE SH 6 X 18	3
11	14539	SCREW, 3.5 X 13 STFH	3

**NOTE:** parts denoted as left or right hand are from driver's point of view.

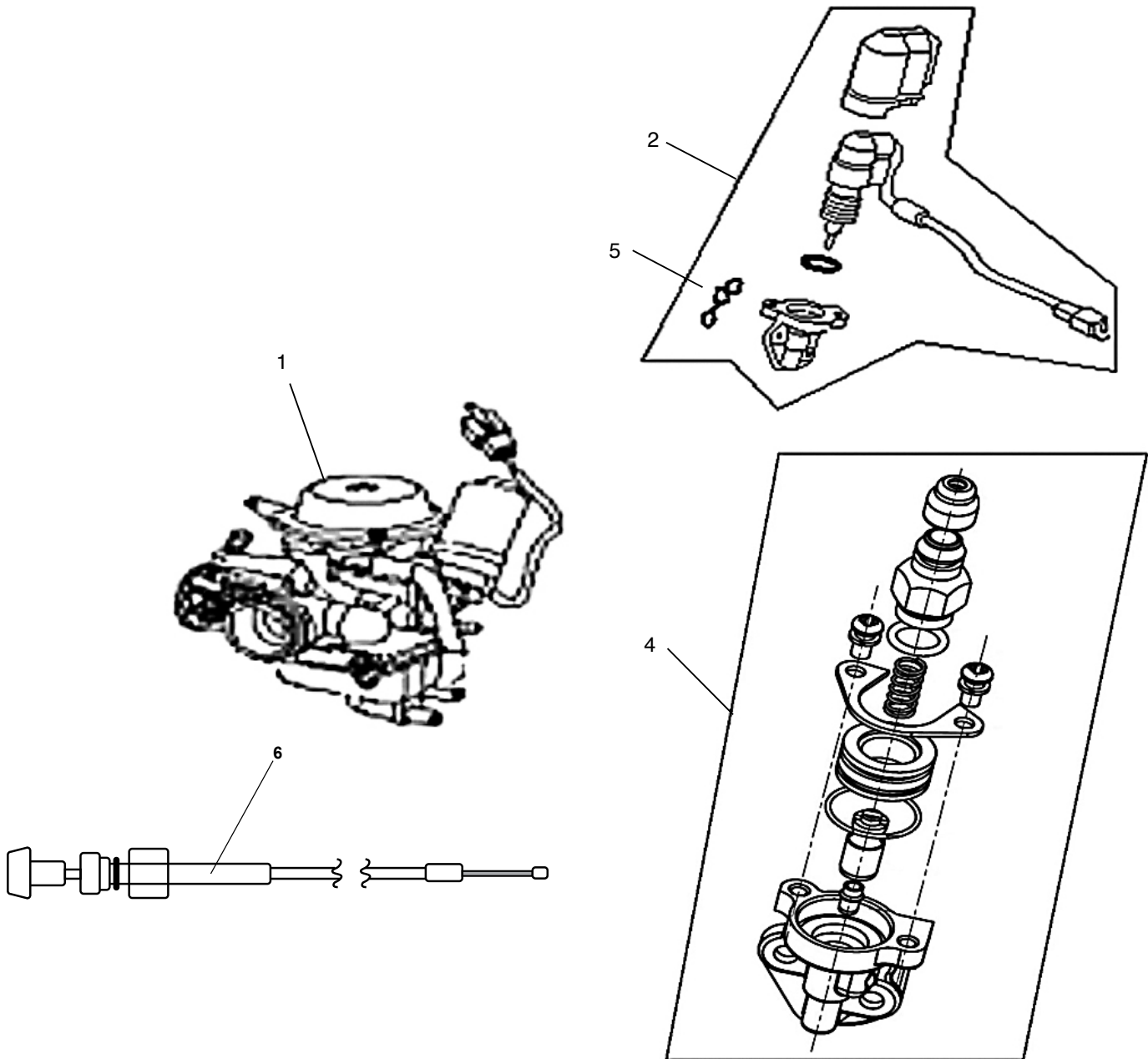

\* For vehicles assembled prior to October 29, 2012.

\*\* For vehicles assembled after October 29, 2012.

**Provide Your American Sportworks Customer Service Representative with the VIN to determine the vehicle's assembly date.**

Ref#	Part#	Description	Qty
1	15856	ASM, CARBURETOR 150CC	1
2	14563	KIT, CARB CHOKE -150CC- DENI/KF CARBS*	1
3	15347	FITTING, VACUUM "Y" - 150CC (NOT SHOWN)	1
4	15458	ASM, MANUAL ENRICHER / CHOKE**	1
5	15460	O-RING, SPECIAL: CARB ENRICHER	1
6	15430	CABLE, CHOKE 3050 MM LONG**	1

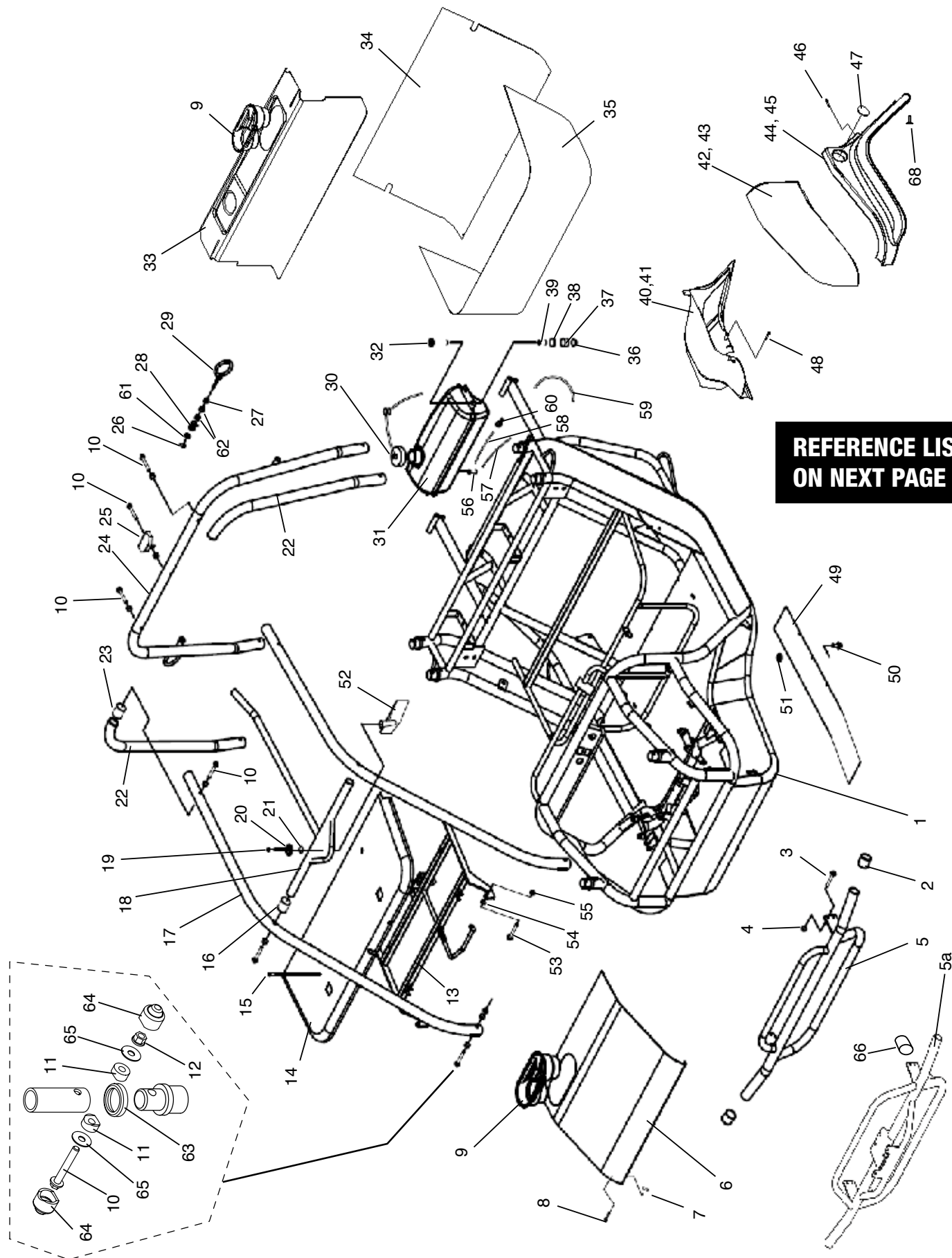

**REFERENCE LIST  
ON NEXT PAGE**

**ILLUSTRATION ON  
PREVIOUS PAGE**

\* For vehicles assembled prior to October 29, 2012.

\*\* For vehicles assembled after October 29, 2012.

**Provide Your American Sportworks Customer Service Representative with the VIN to determine the vehicle's assembly date.**

Ref#	Part#	Description	Qty
1	14858	FRAME, 200 SERIES - CHARCOAL	1
2	14843	CAP, RUBBER BUMPER - 200S	2
3	14436	BOLT, M8 X 1.25 X 25 FHCS ZN	4
4	14088	NUT, M8 X 1.25 LOCKING FLANGE ZN	4
5	14859	BUMPER, 200S - CHARCOAL	1
5a	15112	BUMPER, WINCH MNT - 200 - CHAR	1
6	14804-37	HOOD, 200 SERIES - RED	1
6a	14804-38	HOOD, 200 SERIES - BLUE	1
6b	14804-41	HOOD, 200 SERIES - DK GREEN	1
6c	14804-53	HOOD, 200 SERIES - MENARD GRN	1
6d	14804-48	HOOD, 200 SERIES - CHAR	1
7	14892	NUT, M6 TINNEMAN PLATED	7
8	14820	BOLT, M6 X 1.00 X 14 FHSS	7
9	14842	CUP HOLDER - 200S	2
10	14697	BOLT, M8 X 1.25 X 65 FHCS DAC	13
11	14837	WASHER, CONCAVE CLAMP - 200S	19
12	14088	NUT, M8 X 1.25 LOCKING FLANGE ZN	6
13	14860	FRAME, SEAT TUB COVER - 200S - CHARCOAL	1
14	14861	COVER, SEAT TUB - 200S	1
15	14893	RIVET, 3mm ALUMINUM	N/A
16	14084	ENDCAP, BAR - 1.00 BLACK PLASTIC	3
17	14862	BAR, A PILLAR - 200S - CHARCOAL	2
18	14863	BAR, CENTER CROSS - 200S - CHARCOAL	1
19	14425	BOLT, M5 X .75 X 25 PHMS ZN	1
20	14098	WASHER, MIRROR MOUNT - 7150	1
21	14494	WASHER, M5 SPLIT LOCK ZN	3
22	14864	BAR, B PILLAR RH/LH - 200S - CHARCOAL	2
23	14865	ENDCAP, BAR - 1.5 BLACK PLASTIC	4
24	14866	BAR, C PILLAR - 200S - CHARCOAL	1
25	14956	KIT, CARGO LIGHT - 200S	1
26	15045	CIRCLIP M12 12ID 13.75 OD 1L	2
27	14867	CAP, TOOL HOLDER - 200S	2
28	14868	SPRING, TORSION TOOL HOLDER - 200S	2
29	14869	LOOP, TOOL HOLDER - 200S	2
30	14870	CAP, FUEL W/REMOTE VALVE	1
31	14161	FUEL TANK - CHARCOAL - 6150/7150	1
32	14086	BOLT, M8 X 1.25 X 55 FHCS ZN	4

Ref#	Part#	Description	Qty
33	14871	COVER, REAR DECK - 200S	1
34	14872	BACKSPLASH, SEAT TUB - 200S	1
35	14873	SURROUND, SEAT TUB - 200S	1
36	14088	NUT, M8 X 1.25 LOCKING FLANGE ZN	4
37	14293	WASHER, M8 FLAT ZN	4
38	14163	BUSHING, FUEL TANK MOUNT - 150CC	4
39	14162	SPACER, FUEL TANK - 150CC	4
40	14874	WHEEL WELL, INNER RH - 200S	1
41	14875	WHEEL WELL, INNER LH - 200S	1
42	14876	QUARTER PANEL, UPPER RH - 200S	1
43	14877	QUARTER PANEL, UPPER LH - 200S	1
44	14878	FENDER FLARE, RH - 200S	1
45	14879	FENDER FLARE, LH - 200S	1
46	14827	SCREW, M6 X 1.0 X 15 PHMS NYL - BLK	6
47	14784	REFLECTOR, 54.9 MM - AMBER	2
48	14832	SCREW, M5 X 20 PAN ST - BLK	16
49	14880	SHIELD, CABLE HOUSING - 200S	1
50	14426	BOLT, M6 X 1.00 X 14 FHCS ZN	10
51	14358	NUT, M6 X 1.00 HEX FLANGE	10
52	14090	ASM, REAR VIEW MIRROR - 7150	1
53	14438	BOLT, M8 X 1.25 X 35 HHCS ZN	2
54	14293	WASHER, M8 FLAT ZN	2
55	14088	NUT, M8 X 1.25 LOCKING FLANGE ZN	2
56	50210	AUTO COCK ASSEMBLY*	1
	15454	VALVE, MANUAL ON/OFF/RES W/ O-RING**	1
57	14164	LINE, FUEL #1 - 6150/7150	1
58	14165	LINE, VACUUM #1 - 6150/7150	1
59	14166	LINE, FUEL #2 - 6150/7150	1
60	14167	FILTER, FUEL - 6150/7150	1
61	15046	CAP, TOOL HOLDER D - 200S	2
62	15047	BUSHING, NYLON M12 12ID 20.5 OD 11.25 L	4
63	14941	SEAL, BAR CONNECTION - 1.5 IN	6
64	14945	COVER, BOLT CAP - 1.5 IN	18
65	14944	WASHER, BAR CONNECTION	18
66	15201	CAP, RUBBER BUMPER - WINCH 200	2
67	15255	BUSHING, STEPPED TOOL HOLDER - 200	2
68	15568	SCREW, #12 x .75, FLANGE HEAD	2



# 200 SERIES LUTV SECTION 18 STEERING & BRAKES

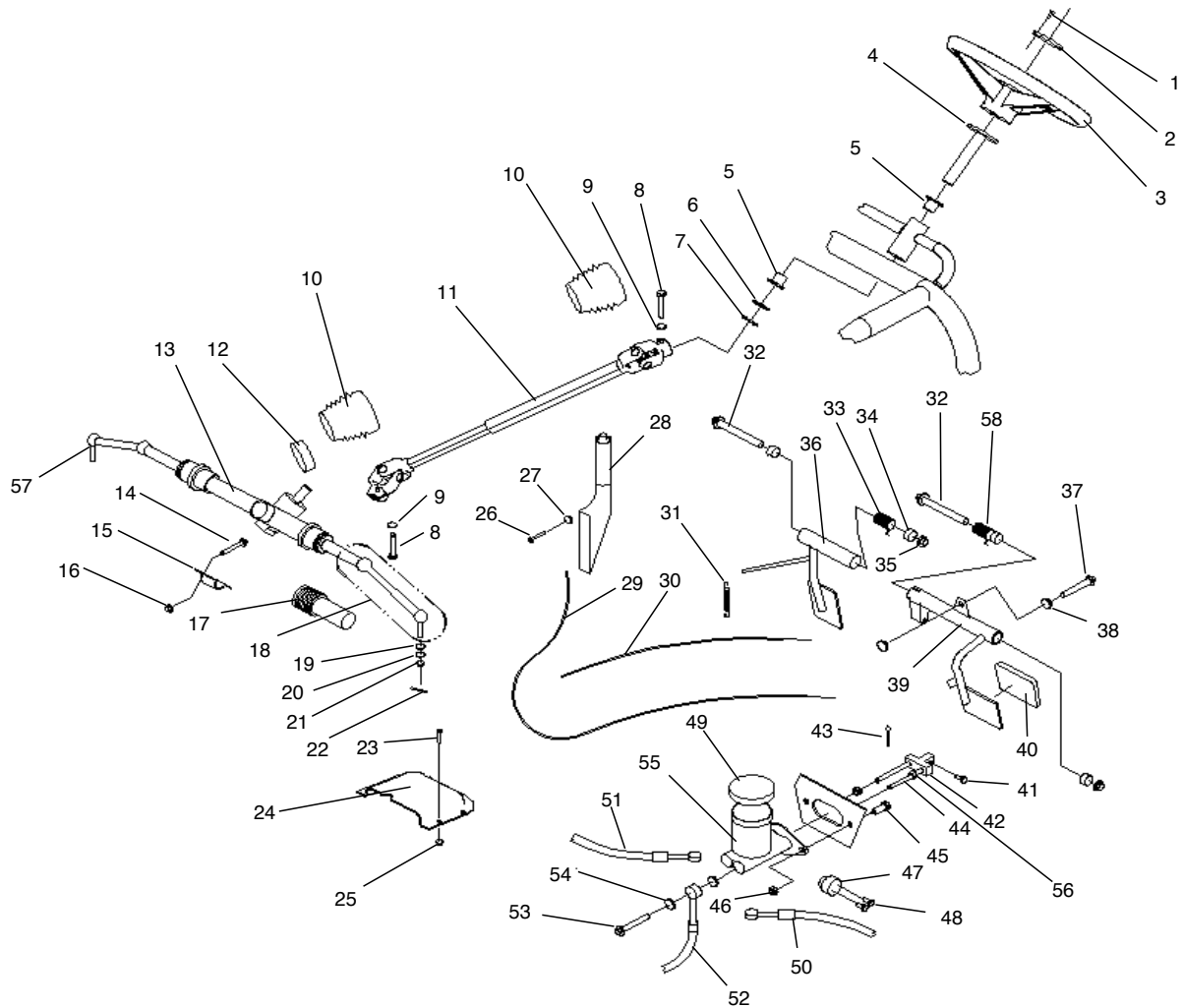

Ref#	Part#	Description	Qty
1	14894	BOLT, M6 X 1.0 X 14 SHCS - ZN	6
2	14846	CAP, STEERING WHEEL - 200S	1
3	14845	STEERING WHEEL - 200S	1
4	14847	SHAFT, STEERING - 200S	1
5	14104	BUSHING, FLANGED SLEEVE 20 X 28 X 24.1	2
6	14895	WASHER, M20 FLAT ZN	1
7	14106	CIRCLIP, M20	1
8	14437	BOLT, M8 X 1.25 X 25 HHCS ZN	2
9	14495	WASHER, M8 SPLIT LOCK ZN	2
10	14412	BOOT, STEERING SHAFT BLACK RUBBER - 7150	2
11	14896	SHAFT, STEERING U-JOINT - 200 SERIES	1
12	14738	DUST SHEILD, R & P BLACK RUBBER - 7150	1
13	14848	ASM, RACK AND PINION - 200S	1
14	14436	BOLT, M8 X 1.25 X 25 FHCS ZN	4
15	14112	BRACKET, RACK AND PINION MNT	2
16	14088	NUT, M8 X 1.25 LOCKING FLANGE ZN	8
17	14109	BOOT, R&P BLACK RUBBER - 7150	2
18	14897	ASM, TIE ROD END - 200 SERIES	2
19	14240	WASHER, M10 FLAT ZN	2
20	14241	WASHER, M10 SPLIT LOCK ZN	2
21	14242	NUT, M10 X 1.25 CASTLE	2
22	14110	PIN, M2 X 15 COTTER	2
23	14426	BOLT, M6 X 1.00 X 14 FHCS ZN	5
24	14900	COVER, FLOOR BRAKE ACCESS - 200S	1
25	14236	NUT, M6 X 1.00 NYLOC ZN	5
26	14426	BOLT, M6 X 1.00 X 14 FHCS ZN	2
27	14236	NUT, M6 X 1.00 NYLOC ZN	2
28	14849	HANDLE, PARK BRAKE - 200S	1
29	14850	CABLE, PARK BRAKE - 200S	1

Ref#	Part#	Description	Qty
30	14851	CABLE, THROTTLE - 200S	1
31	14852	SPRING, THROTTLE PEDAL - 200S	1
32	14442	BOLT, M8 X 1.25 X 145 HHCS ZN	1
33	14113	SPRING, THROTTLE PEDAL - 7150	1
34	14119	BUSHING, SLEEVE 12 X 21 X 12	4
35	14088	NUT, M8 X 1.25 LOCKING FLANGE ZN	8
36	14853-48	PEDAL, THROTTLE - 200S - CHAR	1
37	14439	BOLT, M8 X 1.25 X 40 FHCS ZN	2
38	14610	NUT, M8 X 1.25	4
39	14854-48	PEDAL, BRAKE - 200S - CHAR	1
40	2-70261	PAD, RUBBER-BRAKE	2
41	14116	PIN, M6 X 24 BRAKE BLOCK - 6150/7150	1
42	14101	T BLOCK, BRAKE - 7150	1
43	14489	PIN, M2 X 12 COTTER	1
44	14117	PUSHROD, BRAKE ADJUST - 7150	2
45	14438	BOLT, M8 X 1.25 X 35 HHCS ZN	2
46	14088	NUT, M8 X 1.25 LOCKING FLANGE ZN	2
47	14118	SWITCH, BRAKE LIGHT - 7150	1
48	14454	SCREW, M3 X .5 X 6 PHMS ZN	2
49	14131	CAP, BRAKE MASTER CYL - 7150	1
50	15466	HOSE, HYD BRAKE - 26"	1
51	14129	HOSE, HYD BRAKE - 43"	1
52	14130	HOSE, HYD BRAKE - 75"	1
53	14460	BOLT, M10 X 24 BRAKE BANJO	3
54	14127	WASHER, BRASS BRAKE LINE	6
55	14121	ASM, MASTER CYLINDER - 7150	1
56	14610	NUT, M8 X 1.25 DAC	2
57	15316	BOOT, TIE ROD 150CC	2
58	14120	SPRING, BRAKE PEDAL	1

NOTE: parts denoted as left or right hand are from driver's point of view.

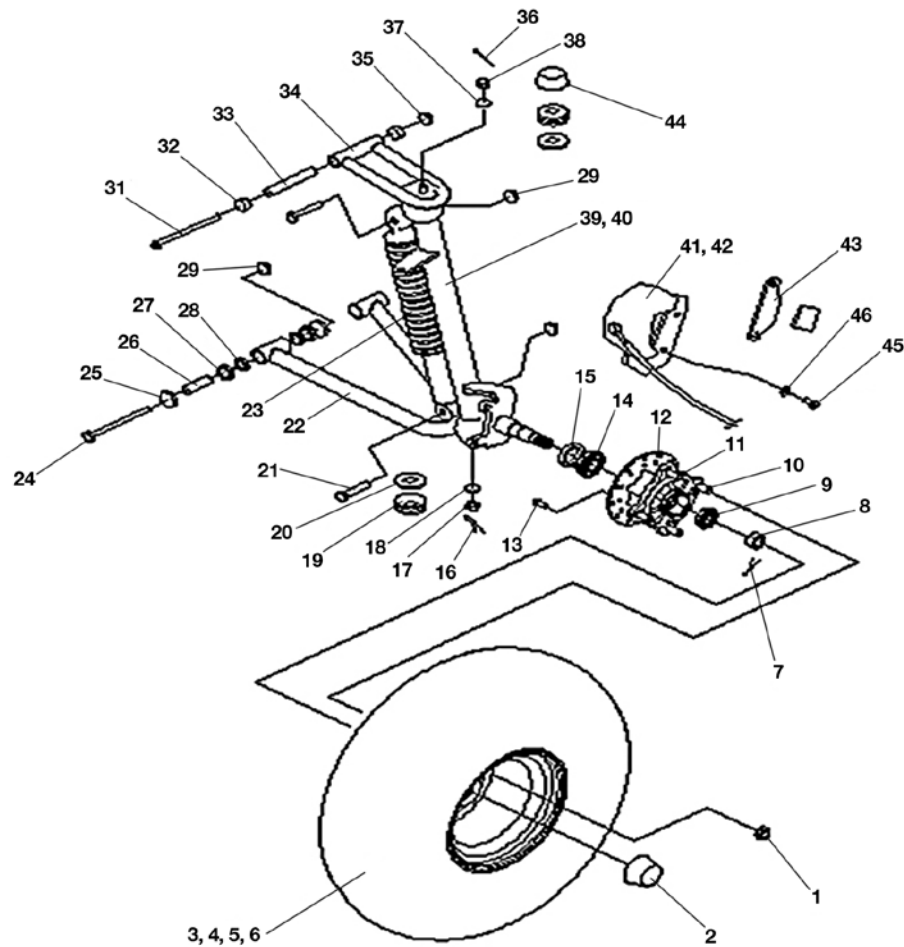

\* Use prior to VIN L6KUA0075EKB04807

\*\* Use on VIN L6KUA0075EKB04807 and after

Ref#	Part#	Description	Qty
1	13979	NUT, M10 X 1.25 WF ZN	8
2	14151	CAP, HUB NOSE - BLACK RUBBER	2
3	14809	ASM, TIRE/WH RH - 20X7-8	1
4	14810	ASM, TIRE/WH LH - 20X7-8	1
5	14813	TIRE, FRONT 20X7-8 - FAR EAST	2
6	14755	WHEEL, 8 X 5 4-110MM, SILVER	2
7	14150	PIN, M2 X 20 COTTER	2
8	14727	NUT, M14 X 1.25 CASTLE	2
9	14149	BEARING, OUTER - 6202-Z *	2
	15339	BEARING, OUTER - 3202-2RS **	2
10	14147	STUD, M10 X 1.25 X 31 WHEEL	8
11	14148	HUB, FRONT WHEEL - 6150/7150	2
12	14144	DISC, FRONT BRAKE - 7150	2
13	14237	BOLT, M6 X 1.00 X 12 HHCS DAC	12
14	14146	BEARING, INNER - 6204-Z	2
15	14145	SEAL, M47 X 25 X 7 DUST	2
16	14490	PIN, M1.8 X 20 COTTER	2
17	14244	NUT, M12 X 1.25 CASTLE	2
18	14245	WASHER, M12 SPLIT LOCK ZN	2
19	14137	SEAL, BALL JOINT - 6150/7150	4
20	14138	SPACER, BALL JOINT HEAD - 6150/7150	4
21	14246	BOLT, M10 X 1.25 X 40 FHCS ZN	4
22	14157-48	A ARM, LOWER - CHAR W/ ZERK	2
23	14808	SHOCK, 325MM FRONT - CHR/BLK	2
24	14447	BOLT, M10 X 1.25 X 80 FHCS ZN	4

Ref#	Part#	Description	Qty
25	14154	CAP, DUST - LWR SUSP ARM - 7150	8
26	14140	SPANNER, A ARM LOWER - 7150	4
27	14155	BUSHING, FLANGED SLEEVE 15 X 21 X 16	8
28	14156	O-RING, M21.2 X 2.65	8
29	14243	NUT, M10 X 1.25 LOCKING FLANGE ZN	8
30	14594	GREASE ZERK - 7150	6
31	14133	BOLT, M8 X 1.25 X 105 FHCS ZN	2
32	14126	BUSHING, FLANGED SLEEVE 12 X 16 X 12	4
33	14134	SPANNER, A ARM UPPER - 7150	2
34	14136-48	A ARM, UPPER - CHAR W/ ZERK	2
35	14088	NUT, M8 X 1.25 LOCKING FLANGE ZN	2
36	14490	PIN, M1.8 X 20 COTTER	2
37	14245	WASHER, M12 SPLIT LOCK ZN	2
38	14244	NUT, M12 X 1.25 CASTLE	2
39	14139	ASM, STRUT/SPINDLE LH - CHAR - 7150 *	1
	15340	ASM, STRUT/SPINDLE LH - CHAR - 200 **	1
40	14132	ASM, STRUT/SPINDLE RH - CHAR - 7150 *	1
	15341	ASM, STRUT/SPINDLE RH - CHAR - 200 **	1
41	14152	ASM, BRAKE CALIPER - RF - 7150	1
42	14143	ASM, BRAKE CALIPER - LF - 7150	1
43	14654	KIT, BRAKE PAD FRONT	2
44	14834	CAP, NUT COVER RUBBER - BLK	2
45	14455	BOLT, M8 X 1.25 X 14 SHCS PL	4
46	14748	WASHER, M8 SPLIT LOCK	4

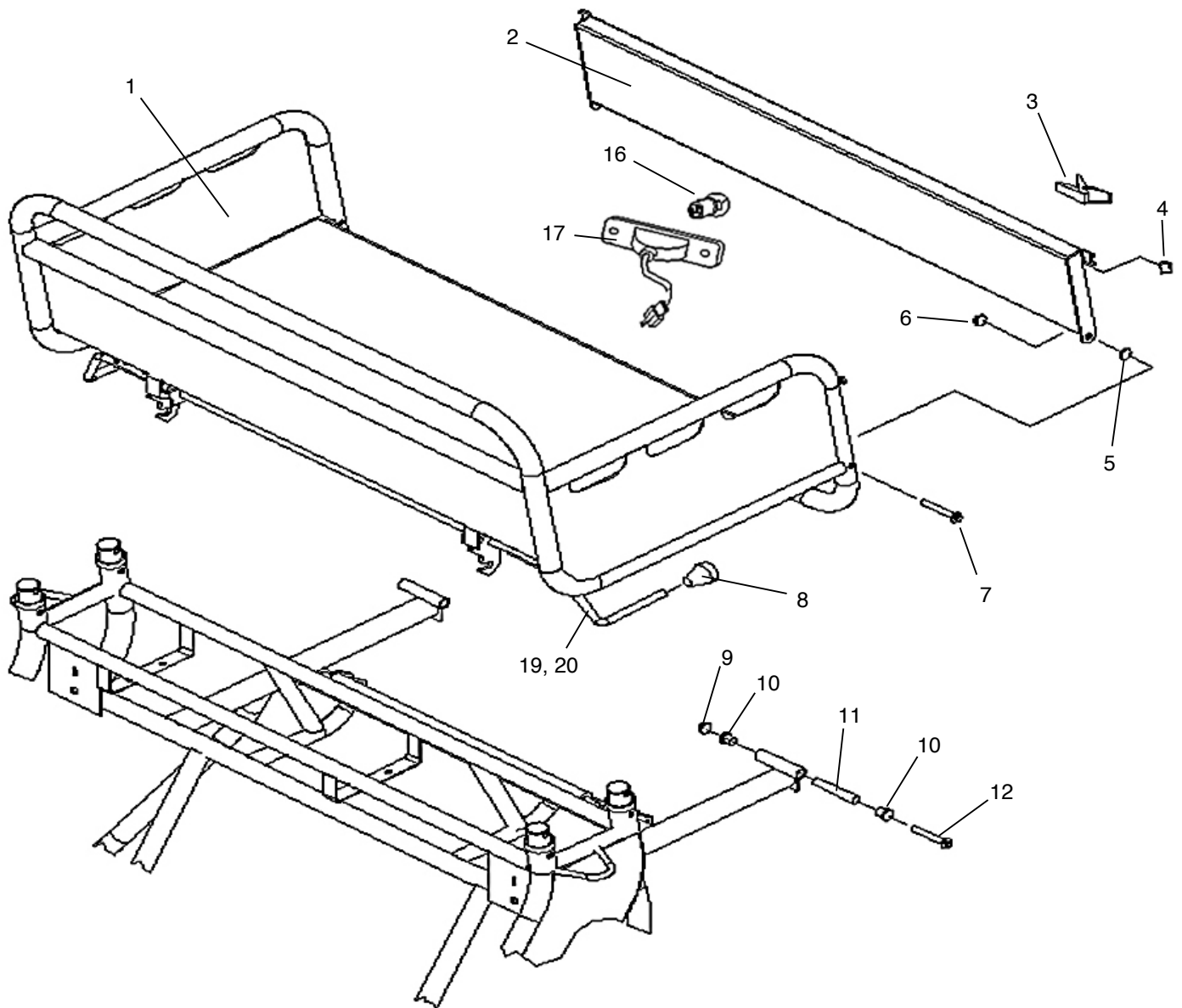

Ref#	Part#	Description	Qty
1	14901	BED, CARGO - 200S - CHARCOAL	1
2	14902	TAILGATE, 200S - CHARCOAL	1
3	14903	LATCH, TAILGATE - 200S - ZN	2
4	14904	BUSHING, TAILGATE - 200S	2
5	14240	WASHER, M10 FLAT	2
6	14243	NUT, M10 X 1.25 LOCKING FLANGE ZN	2
7	15569	BOLT, M10 X 1.25 X 50 FHCS	2
8	14905	KNOB, BED LATCH - 200S - BLK	2
9	14088	NUT, M8 X 1.25 LOCKING FLANGE ZN	2
10	14126	BUSHING, FLANGED SLEEVE 12 X 16 X 12	4

Ref#	Part#	Description	Qty
11	14134	SPANNER, A ARM UPPER - 7150	2
12	14133	BOLT, M8 X 1.25 X 105 FHCS ZN	2
13	14906	PIN, LATCH - 200S	3
14	14907	NUT, LATCH ADJUST - 200S	3
15	14908	BRACKET, LATCH ADJUST - 200S	3
16	14461	BULB, TAIL LIGHT - 12V 10/5W - 7150	1
17	14462	ASM, TAIL LIGHT W/BULB - 7150	1
18	15088	SCREW, BED ADJUST W/ BUMPER	2
19	15081	HANDLE, BED LATCH RH - 200	1
20	15082	HANDLE, BED LATCH LH - 200	1

**NOTE:** parts denoted as left or right hand are from driver's point of view.



 <p><b>WARNING</b> EXHAUST GAS HARMFUL Engine exhaust from this product contains chemicals, known in certain quantities to cause cancer, birth defects, or other reproductive harm.</p>	<p><b>ADVERTENCIA</b> GASES DE ESCAPE NOCIVOS Gases de motor de este producto contienen productos químicos, conocidos que en determinadas cantidades pueden causar cáncer, defectos de nacimiento u otros daños reproductivos.</p>
--	--

11330-NS

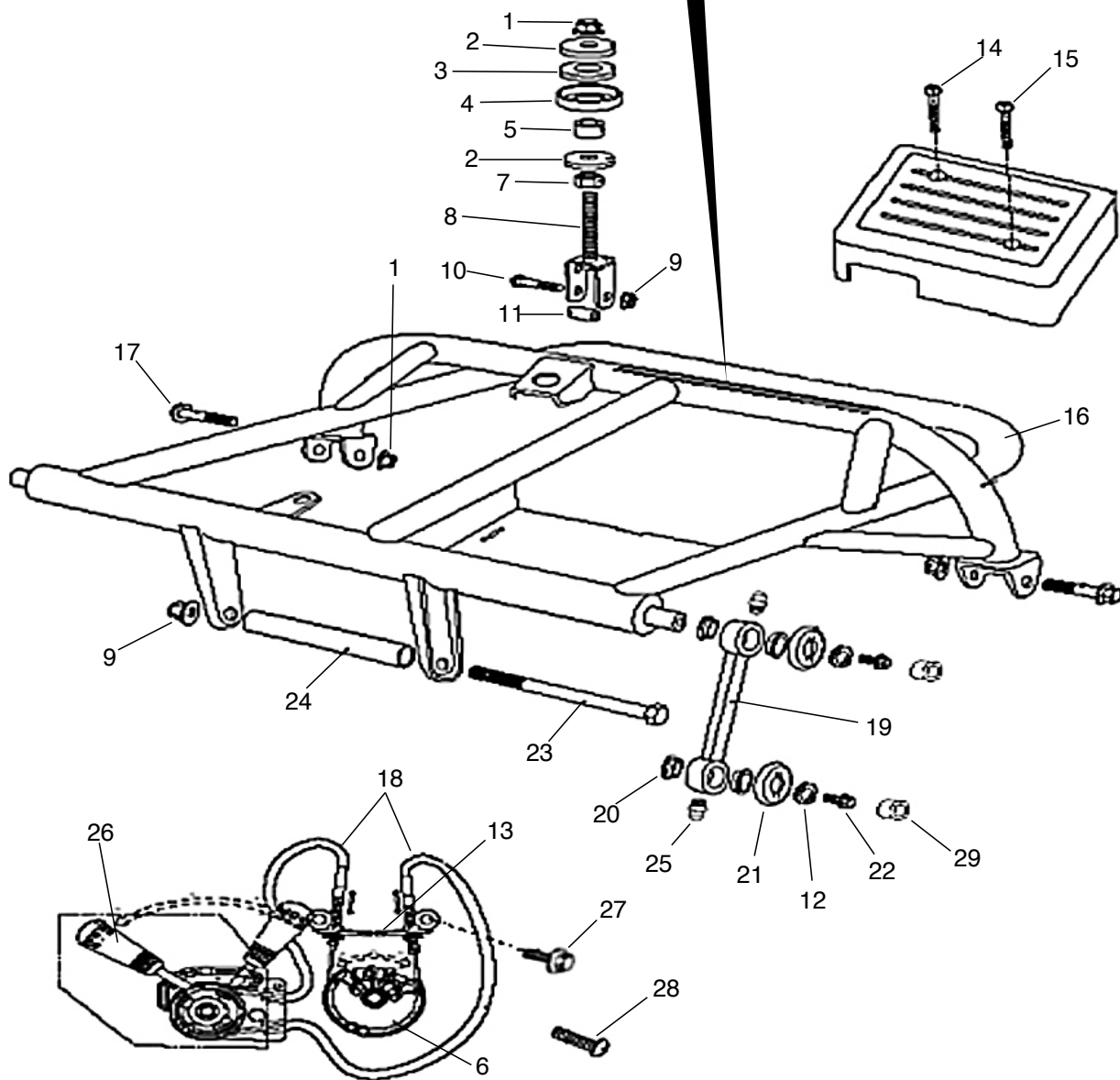

Ref#	Part#	Description	Qty
1	14324	NUT, M12 X 1.25 LOCKING FLANGE ZN	3
2	14710	WASHER - CHAIN ADJUSTER	2
3	14467	BUSHING, ENGINE ADJ ISOLATOR - 150CC	1
4	14468	SPACER, ENGINE ADJ CUP - 150CC	1
5	14469	SPACER, ENGINE ADJ ALIGNMENT - 150CC	1
6	14750	DISC, SHIFT CONTROL - 150CC	1
7	14492	NUT, M12 X 1.25 HEX ZN	1
8	14470	LINK, CHAIN TENSIONING - 150CC	1
9	14243	NUT, M10 X 1.25 LOCKING FLANGE ZN	1
10	14446	BOLT, M10 X 1.25 X 45 FHCS ZN	1
11	14471	SPACER, ENGINE MOUNTING LINK - 150CC	1
12	14748	WASHER, SPLIT LOCK	4
13	14473	BRACKET, SHIFT CABLE - 150CC	1
14	14431	BOLT, M6 X 1.00 X 60 PHMS DAC	2
15	15323	COVER, ELECTRICAL BOX - BOX NO STOP SWIT	1

Ref#	Part#	Description	Qty
16	14173	ASM, UPPER SWINGARM - CHARCOAL - 7150	1
17	14452	BOLT, M12 X 1.25 X 60 FHCS ZN	2
18	14456	CABLE, D/N/R SHIFT - 150CC	2
19	14174	LINK, REAR SWINGARM - CHARCOAL - 7150	2
20	14175	BUSHING, FLANGED SLEEVE 15 X 21 X 10	8
21	14176	SPACER, SWINGARM LINK - 7150	4
22	14434	BOLT, M8 X 1.25 X 16 FHCS ZN	4
23	14449	BOLT, M10 X 1.25 X 195 HHCS ZN	1
24	14177	SPANNER, ENGINE MOUNT - 6150/7150	1
25	14594	GREASE ZERK - 7150	4
26	14749	ASM, TRANS SHIFT LEVER - 150CC	1
27	14426	BOLT, M6 X 1.00 X 14 FHCS ZN	2
28	14341	BOLT, M6 X 1.00 X 20 FHCS ZN	1
29	15389	CAP, SOCKET CAP SCREW - BLACK	4

NOTE: parts denoted as left or right hand are from driver's point of view.

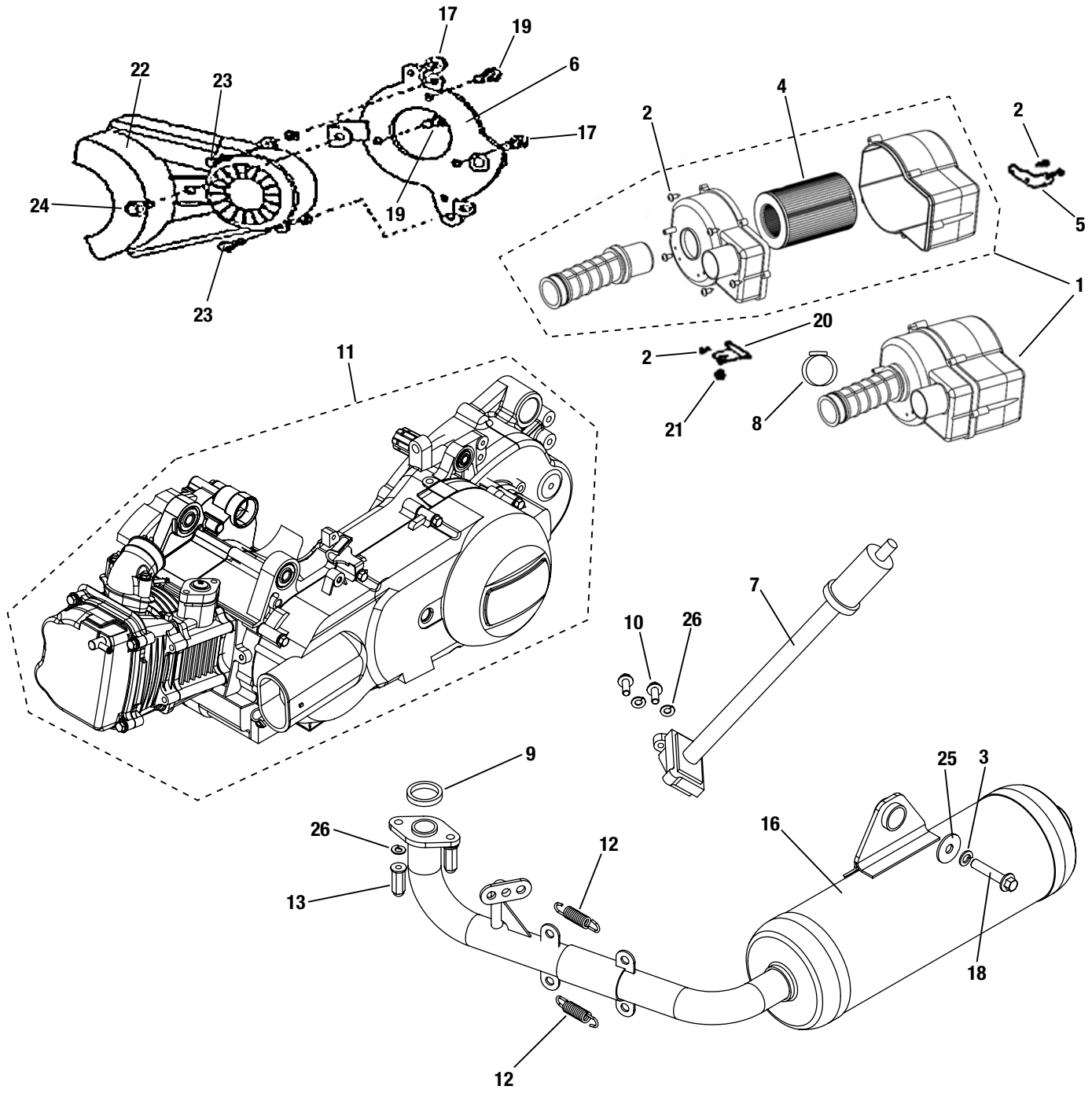



Ref#	Part#	Description	Qty
1	14192	ASM, AIR CLEANER - 150CC	1
2	14423	SCREW, M5 X 16 PHSM ZN	9
3	14495	WASHER, M8 SPLIT LOCK ZN	1
4	14194	FILTER, AIR - 150CC	1
5	14201	BRACKET, #2 AIR CLEANER MNT - 6150/7150	1
6	14480	BRACKET, REAR ENG MOUNT - 150CC	1
7	14762	AIR INJECTION ASM, MUFFLER - 6150/7150	1
8	14481	CLAMP, HOSE 45MM	2
9	14196	GASKET, EX PIPE - 150CC	1
10	14372	BOLT, M6 X 1.00 X 16 FHCS	2
11	14531	ASM, ENGINE - 7150	1
12	14482	SPRING, EXHAUST PIPE - 150CC	2

Ref#	Part#	Description	Qty
13	50050	NUT (HEX) CAP M6	2
16	14760	ASM, MUFFLER W/ AIR INJ MOUNT-6150/7150	1
17	14433	BOLT, M8 X 1.25 X 15 FHCS ZN	1
18	14439	BOLT, M8 X 1.25 X 40 FHCS ZN	1
19	14433	BOLT, M8 X 1.25 X 15 FHCS	3
20	14200	BRACKET, #1 AIR CLEANER MNT - 6150/7150	1
21	14445	BOLT, M8 X 1.25 X 10 FHCS ZN	1
22	14484	GUARD, CHAIN - 150CC	1
23	14430	BOLT, M6 X 1.00 X 30 FHCS	2
24	14436	BOLT, M8 X 1.25 X 30 FHCS	1
25	14497	WASHER, M8 X 27 X 2 FLAT ZN	1
26	14238	WASHER, M6 SPLIT LOCK DAC	4

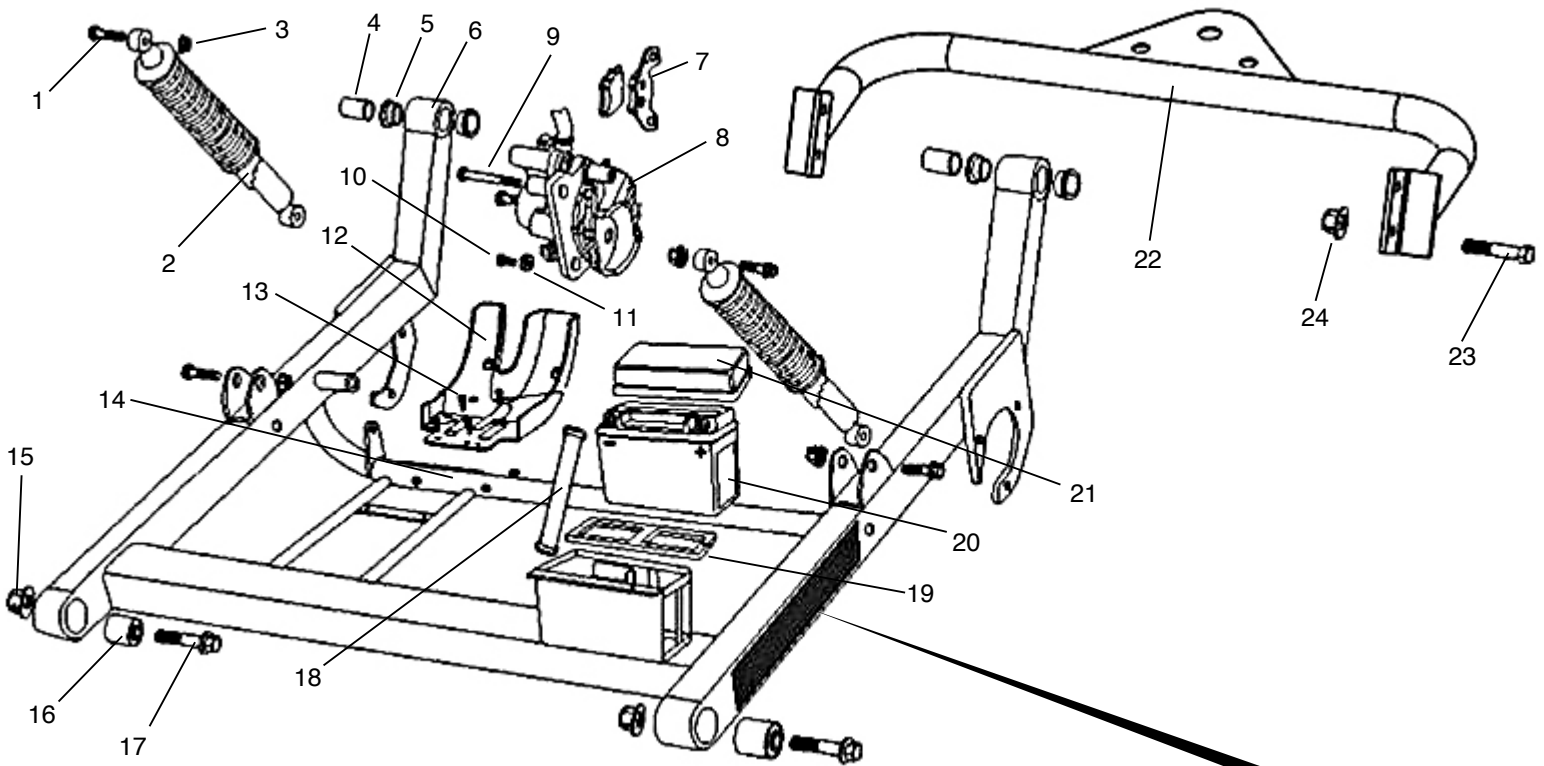
**NOTE: parts denoted as left or right hand are from driver's point of view.**



 <b>WARNING</b> <b>HOT SURFACES</b> Surfaces around the engine and exhaust can be extremely hot. Allow surfaces to cool before servicing.	 <b>ADVERTENCIA</b> <b>SUPERFICIES CALIENTES</b> Las superficies alrededor del motor y el escape pueden estar extremadamente calientes. Permita que las superficies se enfríen antes de realizar el mantenimiento.
--	---

11330-AS

Ref#	Part#	Description	Qty
1	14246	BOLT, M10 X 1.25 X 40 FHCS ZN	4
2	14535	SHOCK, REAR - CHR/YELLOW - 6150/7150	2
3	14243	NUT, M10 X 1.25 LOCKING FLANGE ZN	4
4	14485	SPANNER, M18 X 37 - 150CC	2
5	14182	BUSHING, REAR SWINGARM UPPER - 7150	4
6	15526	WDMT, LOWER SWINGARM - 200	1
7	14183	KIT, REAR BRAKE PAD - 7150	1
8	14184	ASM, REAR CALIPER W/PARK - 7150	1
9	14441	BOLT, M8 X 1.25 X 100 FHCS ZN	1
10	14432	BOLT, M8 X 1.25 X 12 HHCS ZN	1
11	14500	WASHER, M8 STAR ZN	1
12	14185	GUARD, LOWER CHAIN - 6150/7150	1

Ref#	Part#	Description	Qty
13	14372	BOLT, M6 X 1.00 X 16 FHCS ZN	3
14	14236	NUT, M6 X 1.00 NYLOC FLANGE ZN	3
15	14324	NUT, M12 X 1.25 LOCKING FLANGE ZN	2
16	14191	BUSHING, SWINGARM ISOLATOR - 6150/7150	2
17	14452	BOLT, M12 X 1.25 X 60 FHCS ZN	2
18	14187	STRAP, BATTERY HOLD DOWN - 6150/7150	1
19	14188	GASKET, BATTERY CAP - 6150/7150	1
20	14189	BATTERY - GTX9-BS	1
21	14186	COVER, BATTERY - 6150/7150	1
22	15525	HITCH, BOLT-ON FOR 200 SERIES MODELS	1
23	15422	BOLT, 3/8"-16 X 1.75" HHCS BLK DAC	4
24	15442	NUT, 3/8"-16 HEX CENTERLOCK DAC	4

NOTE: parts denoted as left or right hand are from driver's point of view.

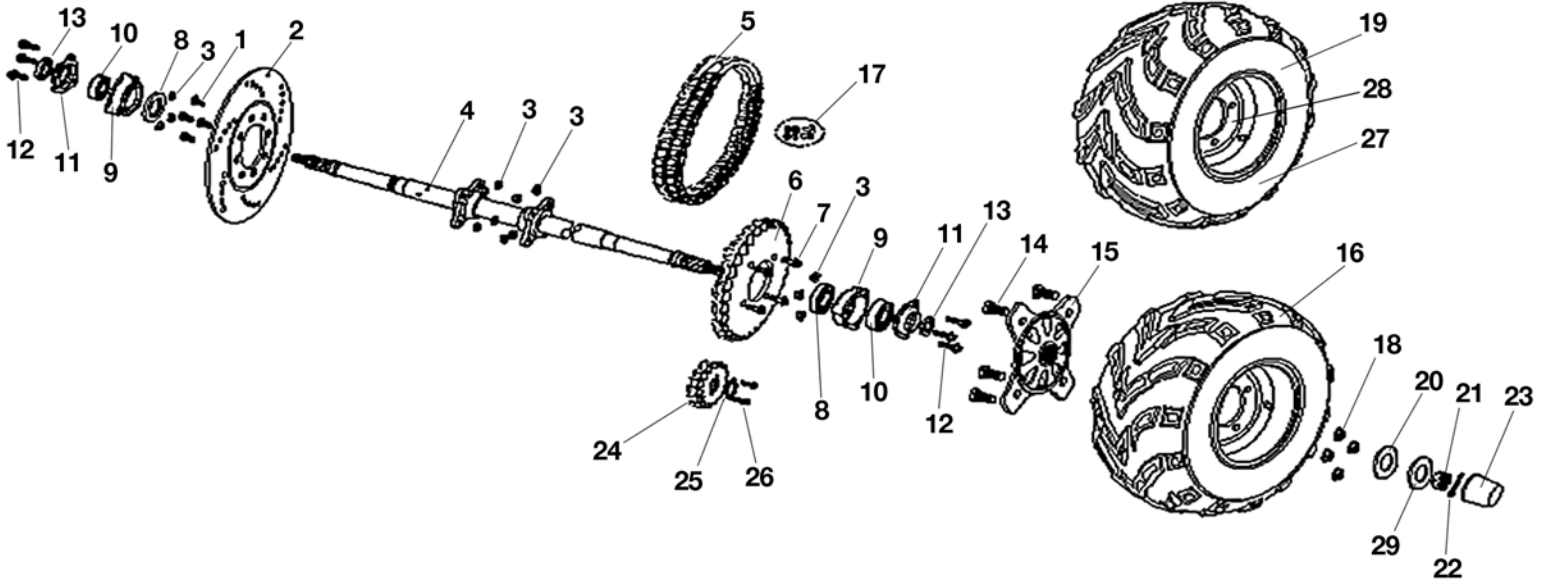

\* Use prior to VIN L6KUA0076FBB05241

\*\* Use on VIN L6KUA0076FBB05241 and after

Ref#	Part#	Description	Qty
1	14435	BOLT, M8 X 1.25 X 22 FHCS ZN	4
2	14202	DISC, 8.75 REAR BRAKE - 6150/7150	1
3	14088	NUT, M8 X 1.25 LOCKING FLANGE ZN	16
4	14816	AXLE, TAPERED END - 200 SERIES	1
5	14831	CHAIN, DBL ROW 54 X 50P INCL ML	1
6	14819	SPROCKET, DBL ROW 40T - 200S	1
7	14436	BOLT, M8 X 1.25 X 25 FHCS ZN	4
8	14206	SEAL, M50 X 34 X 7 DUST	2
9	14207	HOUSING, AXLE BRG - 6150/7150	2
10	14208	BEARING - 6206	2
11	14209	FLANGE, BEARING - 6150/7150	2
12	14439	BOLT, M8 X 1.25 X 40 FHCS ZN	6
13	14210	SEAL, M42 X 30 X 7 DUST	2
14	14147	STUD, M10 X 1.25 X 31 WHEEL	8
15	14817	HUB, TAPERED 150CC - 4-165MM	2

Ref#	Part#	Description	Qty
16	14811	ASM, TIRE/WH FAR WAY RH - 22X10-10	1
17	14912	MASTER LINK, DR 50 CHAIN	1
18	13979	NUT, M10 X 1.25 WF ZN	8
19	14812	ASM, TIRE/WH FAR WAY LH - 22X10-10	1
20	14248	SPACER, M16 X 16 X 4	2
21	14249	NUT, M16 X 2.00 CASTLE	2
22	14213	PIN, M4 X 30 COTTER *	2
	15387	PIN, M3.2 X 32 COTTER **	2
23	14151	CAP, HUB NOSE - BLACK RUBBER	2
24	14830	SPROCKET, DBL ROW 50P 12T - 200S	1
25	14218	KEEPER, SPROCKET - 6150/7150	1
26	14296	BOLT, M6 X 1.00 X 12 FHCS ZN	2
27	14814	TIRE, 22X10-10 - FAR EAST	1
28	14758	WHEEL, 10 X 9.5 4-165MM, SILVER	2
29	15384	WASHER, BELLEVILLE, M16 **	2

**NOTE:** parts denoted as left or right hand are from driver's point of view.

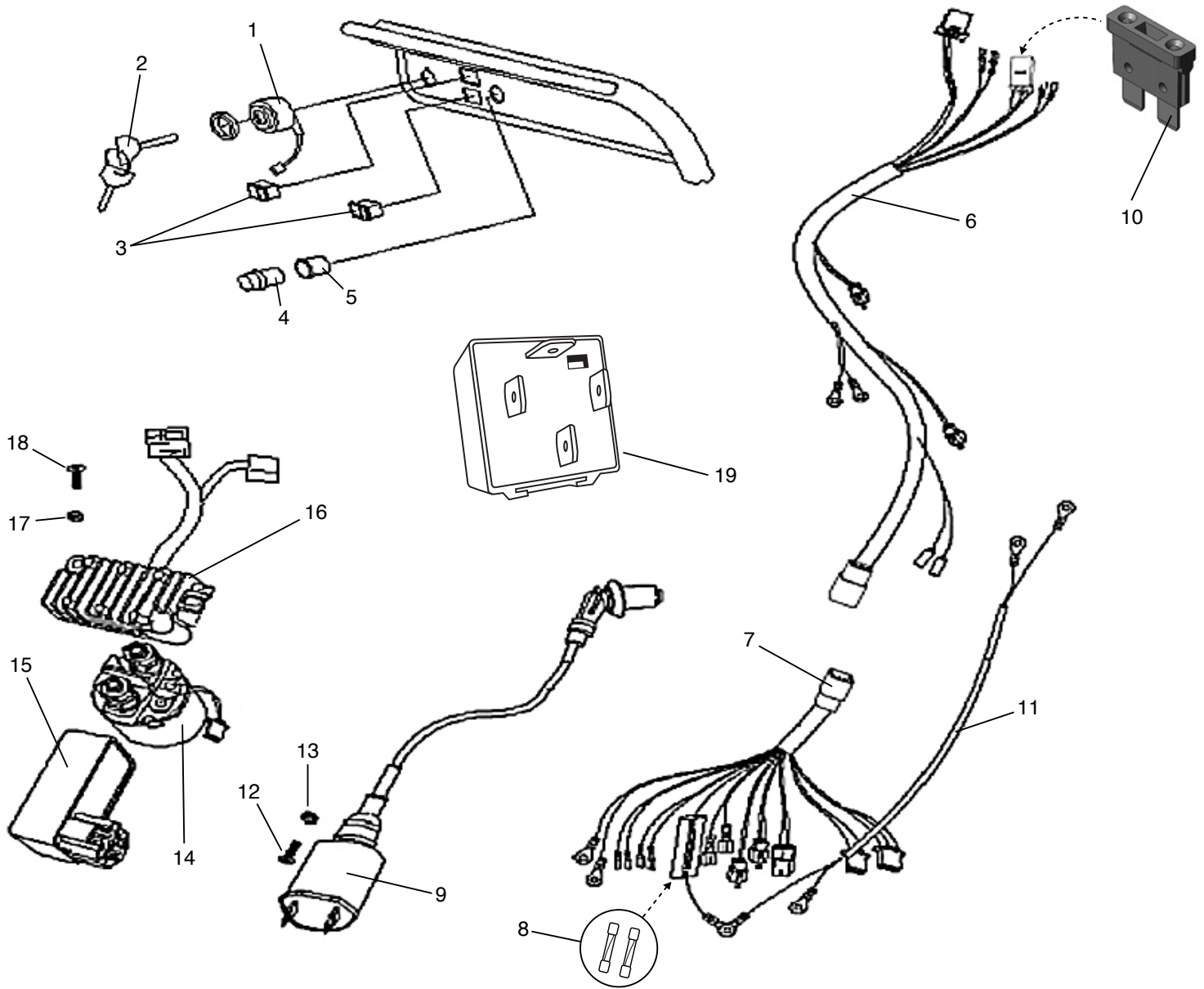

\* 2011 and newer models

\*\* available at most automotive part stores.

Ref#	Part#	Description	Qty
1	14222	SWITCH, KEYED IGNITION W/KEY - 6150/7150	1
2	14588	KEY SET - 6150/7150	1
3	14220	SWITCH, HEADLIGHT - 7150	2
4	14914	PLUG, WEATHER - 12V OUTLET	1
5	14915	OUTLET, 12V 15A	1
6	14916	HARNESS, MAIN WIRING - 200S	1
6a*	15084	HARNESS, MAIN W/ FUSE - 200	1
7	14740	HARNESS, SWINGARM WIRING - 7150	1
7a*	15083	HARNESS, SWINGARM HO ALT - 200	1
8	14231	FUSE, 15AMP - WAYTEK 46115	2
9	14227	COIL, IGNITION W/CAP - 6150/7150	1

Ref#	Part#	Description	Qty
10*		FUSE, 15AMP ATC/ATO BLADE FUSE **	2
11	14486	HARNESS, BATTERY - 150CC	1
12	14425	BOLT, M5 X .75 X 25 PHMS ZN	1
13	14491	NUT, M5 X .75 NYLOC ZN	1
14	14225	RELAY, STARTER - 6150/7150	1
15	14226	CDI - 6150/7150	1
16	14224	REGULATOR, VOLTAGE - 6150/7150	1
16a*	15085	REGULATOR, VOLTAGE - HO ALTERNATOR - 200	1
17	14236	NUT, M6 X 1.00 NYLOC FLANGE ZN	2
18	14428	SCREW, M6 X 1.00 X 20 PHMS DAC	2
19	15016	RELAY, BRAKE INTERLOCK - 200S	1

NOTE: parts denoted as left or right hand are from driver's point of view.

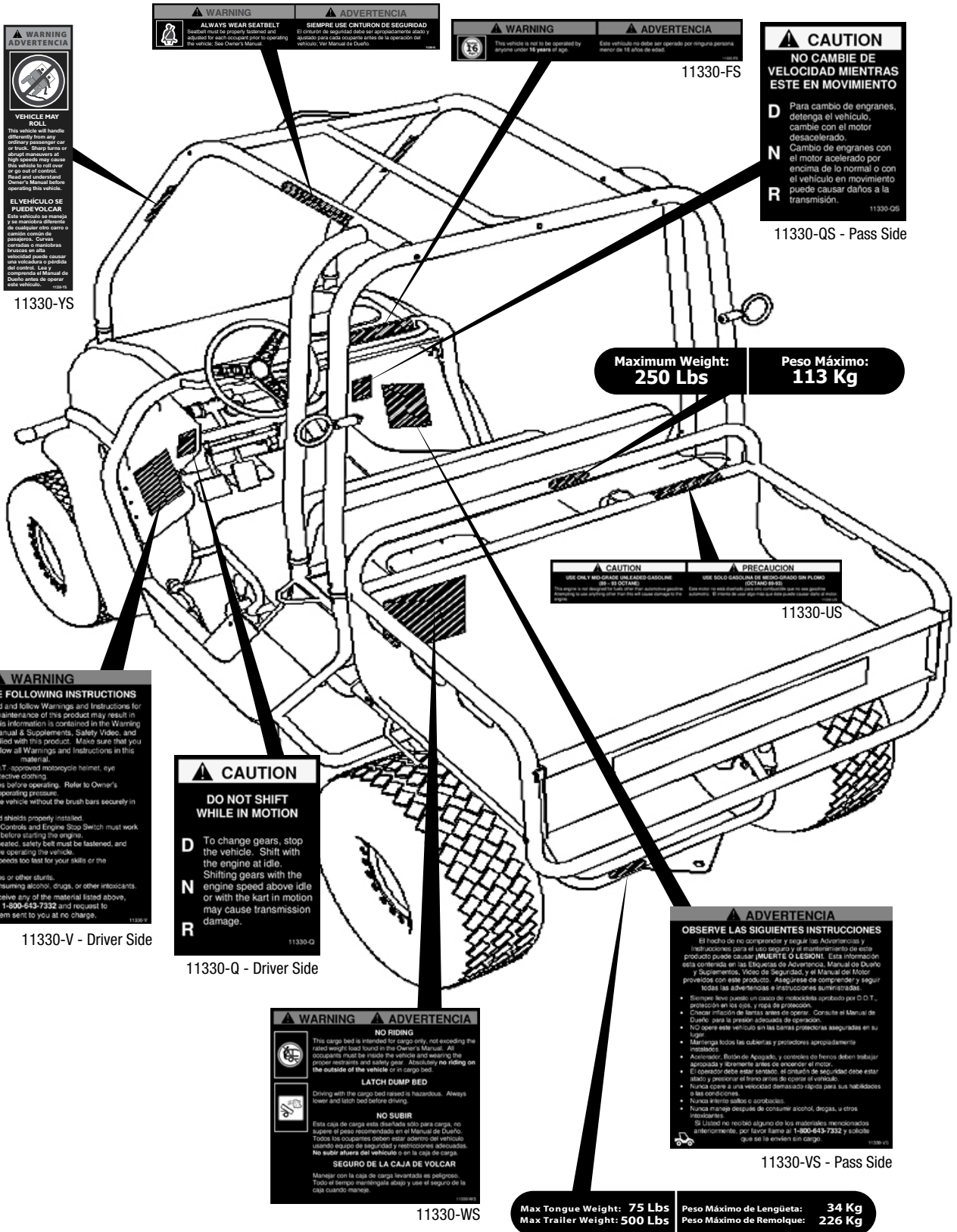

**WARNING ADVERTENCIA**

**VEHICLE MAY ROLL**  
This vehicle will handle differently from any ordinary passenger car or truck. Sharp turns or abrupt maneuvers at high speeds may cause this vehicle to roll over or tip out of control. Read and understand Owner's Manual before operating this vehicle.

**EL VEHICULO SE PUEDE VOLCAR**  
Este vehiculo se maneja de manera diferente de cualquier otro carro o camion ordinario de pasajeros. Curvas o maniobras bruscas a altas velocidades pueden causar una volcadura o puetada del control. Lea y comprenda el Manual de Datos antes de operar este vehiculo.

11330-YS

**WARNING** **ADVERTENCIA**

**ALWAYS WEAR SEATBELT**  
Seatbelt must be properly fastened and adjusted for each occupant prior to operating the vehicle. See Owner's Manual.

**SIEMPRE USE CINTURON DE SEGURIDAD**  
El cinturón de seguridad debe ser apropiadamente usado y ajustado para cada ocupante antes de la operación del vehículo. Ver Manual de Datos.

**WARNING** **ADVERTENCIA**

This vehicle is not to be operated by anyone under 16 years of age.

Este vehiculo no debe ser operado por ninguna persona menor de 16 años de edad.

11330-FS

**CAUTION**

**NO CAMBIE DE VELOCIDAD MIENTRAS ESTE EN MOVIMIENTO**

**D** Para cambio de engranes, detenga el vehiculo, cambie con el motor desacelerado.

**N** Cambio de engranes con el motor acelerado por encima de lo normal o con el vehiculo en movimiento puede causar danos a la transmision.

**R**

11330-QS - Pass Side

**Maximum Weight: 250 Lbs** **Peso Máximo: 113 Kg**

**CAUTION** **PRECAUCION**

USE ONLY MID-GRADE UNLEADED GASOLINE (89-92 OCTANE)

USE SOLO GASOLINA DE MEDIO-GRADO SIN PLOMO (OCTANAS 89-92)

11330-US

**WARNING**

**OBSERVE THE FOLLOWING INSTRUCTIONS**  
Failure to understand and follow Warnings and Instructions for the safe use and maintenance of this product may result in **Death or Injury!** This information is contained in the Warning Labels, Owner's Manual & Supplements, Safety Video, and Engine Manual supplied with this product. Make sure that you understand and follow all Warnings and Instructions in this material.

- Always wear a D.O.T. approved motorcycle helmet, eye protection, and protective clothing.
- Check tire pressures before operating. Refer to Owner's Manual for proper operating pressures.
- Do NOT operate the vehicle without the brush bars securely in place.
- Keep all covers and shields properly installed.
- Throttle and Brake Controls and Engine Stop Switch must work properly and freely before starting the engine.
- Operator must be seated, safety belt must be fastened, and brake applied before operating the vehicle.
- Never operate at speeds too fast for your skills or the conditions.
- Never attempt jumps or other stunts.
- Never ride after consuming alcohol, drugs, or other intoxicants.

If you did not receive any of the material listed above, please call 1-800-643-7332 and request to have them sent to you at no charge.

11330-V - Driver Side

**CAUTION**

**DO NOT SHIFT WHILE IN MOTION**

**D** To change gears, stop the vehicle. Shift with the engine at idle.

**N** Shifting gears with the engine speed above idle or with the kart in motion may cause transmission damage.

**R**

11330-Q - Driver Side

**WARNING** **ADVERTENCIA**

**NO RIDING**  
This cargo bed is intended for cargo only, not exceeding the rated weight load found in the Owner's Manual. All occupants must be seated in the vehicle and wearing the proper restraints and safety gear. Absolutely no riding on the outside of the vehicle or in cargo bed.

**LATCH DUMP BED**  
Driving with the cargo bed raised is hazardous. Always lower and latch bed before driving.

**NO SUBIR**  
Esta caja de carga esta disenada solo para carga, no soporte el peso recomendado en el Manual de Datos. Todos los ocupantes deben estar adentro del vehiculo, usando equipo de seguridad y restricciones adecuadas. No subir afuera del vehiculo o en la caja de carga.

**SEGURO DE LA CAJA DE VOLCAR**  
Manejar con la caja de carga levantada es peligroso. Todo el tiempo manténgala abajo y use el seguro de la caja cuando maneje.

11330-WS

**ADVERTENCIA**

**OBSERVE LAS SIGUIENTES INSTRUCCIONES**  
El hecho de no comprender y seguir las Advertencias e Instrucciones para el uso seguro y el mantenimiento de este producto puede causar **MUERTE O LESION!** Esta información está contenida en las Etiquetas de Advertencias, Manual de Datos y Suplementos, Video de Seguridad, y el Manual del Motor provistos con este producto. Asegúrese de comprender y seguir todas las advertencias e instrucciones suministradas.

- Siempre use casco, un casco de motocicleta aprobado por D.O.T., protección en los ojos, ropa de protección.
- Comprobar inflación de llantas antes de operar. Consulte el Manual de Datos para la presión adecuada de operación.
- NO opere este vehículo sin las barras protectoras aseguradas en su lugar.
- Mantenga todos los cubiertas y protectores apropiadamente instalados.
- Antes de operar, Botón de Acelerado, y controles de frenos deben trabajar apropiada y libremente antes de encender el motor.
- El operador debe estar sentado, el cinturón de seguridad debe estar abastado y asegurar el freno antes de operar el vehículo.
- Nunca opere a una velocidad demasiado rápida para sus habilidades o las condiciones.
- Nunca intente saltos o acrobacias.
- Nunca maneje después de consumir alcohol, drogas, u otros intoxicantes.

Si Usted no recibió alguno de los materiales mencionados anteriormente, por favor llame al 1-800-643-7332 y solicite que se le envíen sin cargo.

11330-VS - Pass Side

**Max Tongue Weight: 75 Lbs** **Peso Máximo de Lengüeta: 34 Kg**  
**Max Trailer Weight: 500 Lbs** **Peso Máximo de Remolque: 226 Kg**

# HEADLIGHT REPLACEMENT BULBS AND ASSEMBLIES FOR ASW UTILITY VEHICLES

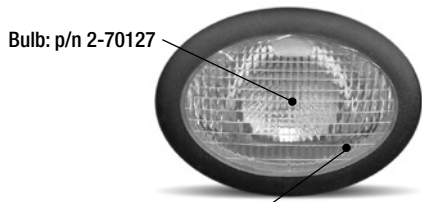

Bulb: p/n 2-70127

Assembly: p/n 2-70129  
(5 1/4" oval)

Bulb: p/n 2-70127

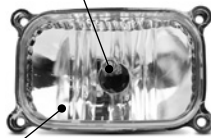

Assembly: p/n 2-70133  
(4 3/8" rectangle)

Bulb: p/n 2-70127



Assembly: p/n 15648  
(3 1/4" Round)

Bulb: Sealed housing  
no bulb available



Assembly: p/n 14768  
(4" round)

Light assembly: p/n 2-70158  
(5" round)

Amber reflector: p/n 14784  
(2 1/4" Round)



Bulb: p/n 2-70122

Plastic insert: p/n "Driver Side" 15944 (inner bezel)  
15946 (outer bezel)

Plastic insert: p/n "Passenger Side" 15943 (inner bezel)  
15945 (outer bezel)

Measurements are taken from left to right of the visible portion of the lens

Light assembly: p/n 2-70153 (driver side)  
Light assembly: p/n 2-70154 (passenger side)

Bulb: p/n 15304

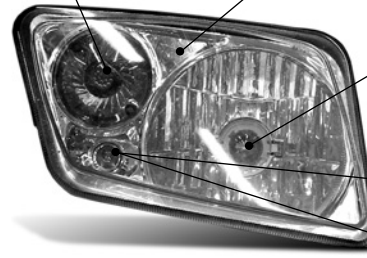

Bulb: p/n 2-70146

Twist-in Bulb:  
Sylvania 1891 or equivalent



Depending on your year of manufacture,  
this housing either has a "push-in" or "twist-in" bulb

Push-in Bulb:  
Sylvania 2825 or equivalent



## ORDERING PARTS

FAST & EASY!

- 1) Seek Part(s) from your models illustrated diagram, cross over REF# to PART#
- 2) Type PART# into sites [Search Box] at [GoKartsRus.com](http://GoKartsRus.com) TIP! - RIGHT CLICK LINK, SELECT OPEN IN NEW TAB
- 3) Add all needed parts to Shopping Cart | Complete "Checkout" | ✓ Done!

If a part does not come up in a Site Search, please [Contact Us](#) (include part# in email)

LOWEST PRICES!