



AMERICAN SPORTWORKS®

200 SERIES LUTV 2015 Model 202

WITH 150cc ENGINE

ORDERING PARTS

FAST & EASY!

- 1) Seek Part(s) from your models illustrated diagram, cross over REF# to PART#
- 2) Type PART# into sites [Search Box] at GoKartsRus.com TIP! - RIGHT CLICK LINK, SELECT OPEN IN NEW TAB
- 3) Add all needed parts to Shopping Cart | Complete "Checkout" | ✓Done!

If a part does not come up in a Site Search, please [Contact Us](#) (include part# in email)

LOWEST PRICE!



150CC 2 WHEEL DRIVE LIGHT UTILITY VEHICLE

ILLUSTRATED PARTS LIST

TABLE OF CONTENTS

SECTION 1 CYLINDER HEAD ASSEMBLY	1
SECTION 2 CYLINDER	2
SECTION 3 ENGINE CRANKCASE	3
SECTION 4 TRANSMISSION	4
SECTION 5 CVT COVER	5
SECTION 6 OUTER CRANKCASE ASSEMBLY	6
SECTION 7 PISTON / CRANK / CONNECTING ROD	7
SECTION 8 CAMSHAFT ASSEMBLY	8
SECTION 9 OIL PUMP ASSEMBLY	9
SECTION 10 DRIVEN PULLEY & CLUTCH	10
SECTION 11 ENGINE ELECTRICAL	11
SECTION 12 ELECTRIC START	12
SECTION 13 DRIVER PULLEY	13
SECTION 14 FAN COVER / SHROUD ASSEMBLY	14
SECTION 15 CARBURETOR	15
SECTION 16 FRAME GROUP	16,18
SECTION 17 STEERING & BRAKES	19
SECTION 18 FRONT SUSPENSION	20
SECTION 19 BED / TAILGATE	21
SECTION 20 ENGINE / MUFFLER / AIR CLEANER	22
SECTION 21 SWINGARM ASSEMBLY	23
SECTION 22 REAR AXLE	24
SECTION 23 ELECTRICAL	25

200 SERIES LUTV SECTION 1 CYLINDER HEAD ASSEMBLY

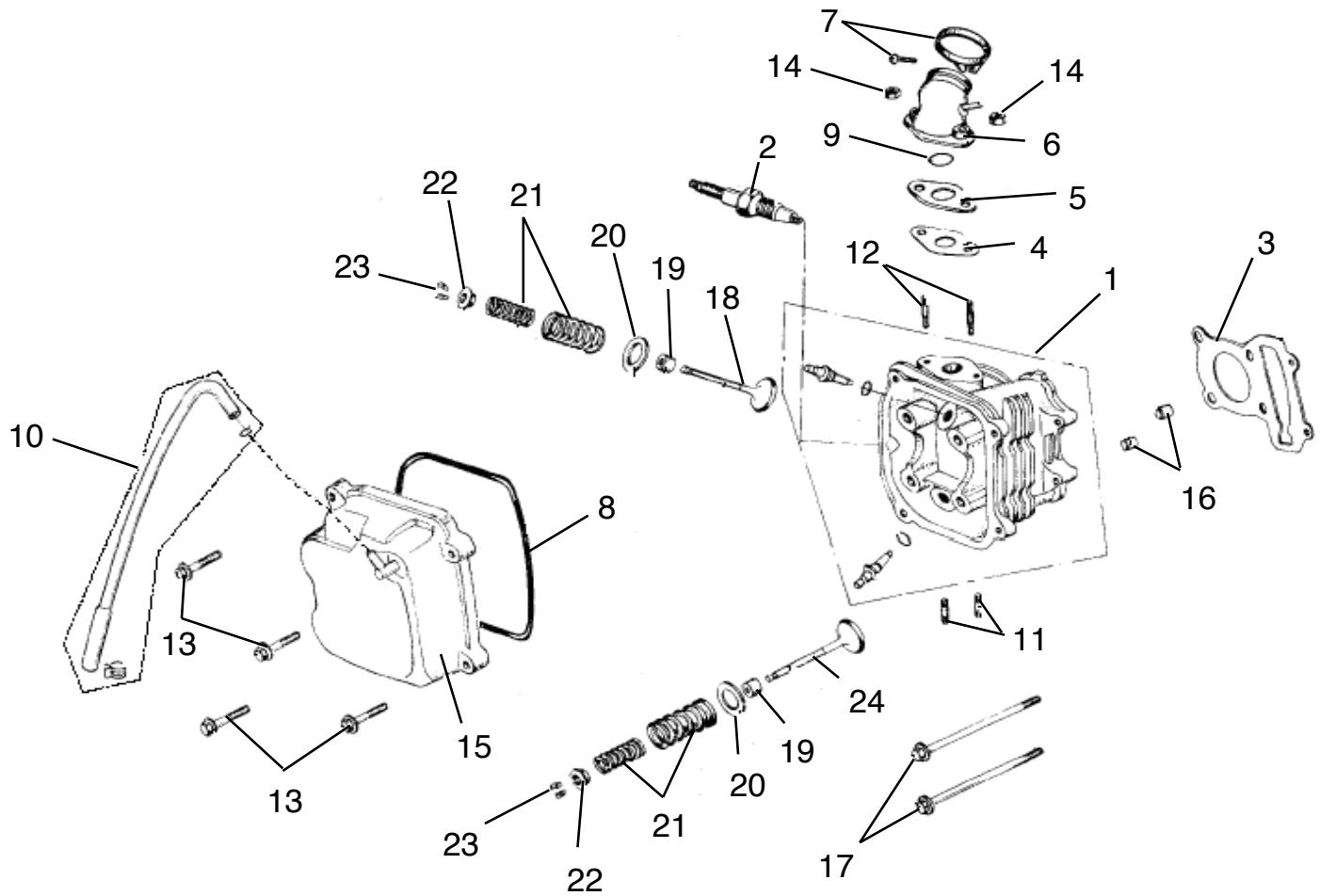

Ref#	Part#	Description	Qty
1	14254	HEAD, CYLINDER - 150CC	1
2	50304	SPARK PLUG (CR7HSA)	1
3	14255	GASKET, CYL HEAD - 150CC	1
4	14256	GASKET, CARB INSULATOR - 150CC	1
5	14257	INSULATOR, CARB - 150CC	1
6	14258	MANIFOLD, INTAKE - 150CC	1
7	14259	CLAMP, CARB HOSE - 150CC	1
8	14260	GASKET, VALVE COVER - 150CC	1
9	14261	O-RING, M27 X 2 RUBBER - 150CC	1
10	14262	TUBE, BREATHER - 150CC	1
11	14263	STUD, M6 X 1.25 X 18	2
12	14264	STUD, M6 X 1.25 X 50	2

Ref#	Part#	Description	Qty
13	50003	BOLT, M6 x 1.00 x 25 HHF	4
14	50024	NUT, M6 x 1.00 HEX FLANGE	2
15	14265	COVER, VALVE - 150CC	1
16	14266	PIN, M10 X 16 DOWEL	2
17	50087	BOLT FLANGE SH 6 X 100	2
18	14267	VALVE, INTAKE - 150CC	1
19	14268	SEAL, VALVE STEM - 150CC	2
20	14269	SEAT, VALVE SPRING OUTER - 150CC	2
21	14270	SPRING, OUTER AND INNER VALVE - 150CC	2
22	14271	RETAINER, VALVE SPRING - 150CC	2
23	14272	KEEPER, VALVE SPRING - 150CC	4
24	14273	VALVE, EXHAUST - 150CC	1

NOTE: parts denoted as left or right hand are from driver's point of view.

200 SERIES LUTV SECTION 2 CYLINDER

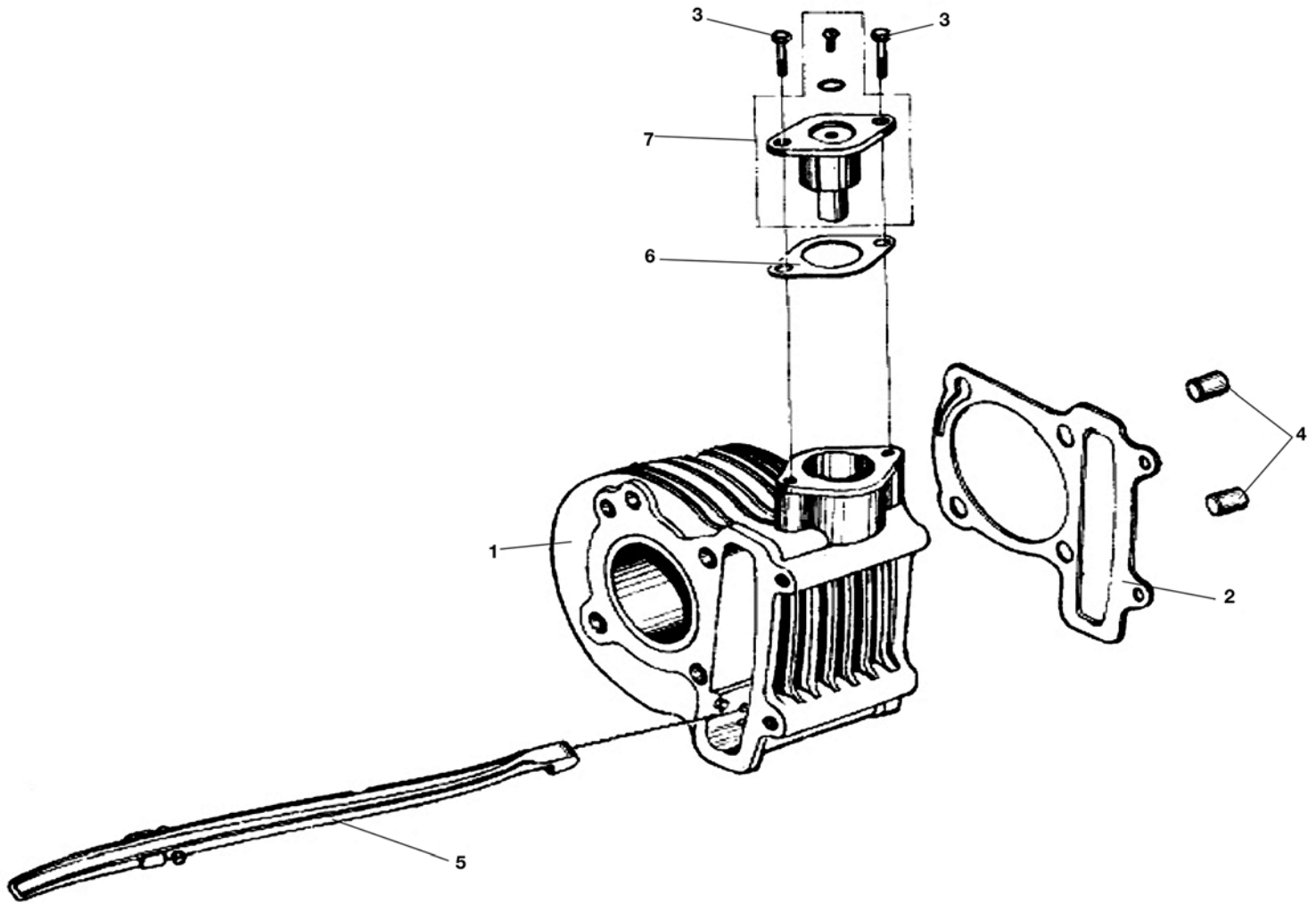

Ref #	Part #	Description	Qty
1	14317	CYLINDER - 150CC	1
2	14582	GASKET, CYLINDER BASE - 150CC	1
3	50032	BOLT FLANGE SH 6 X 22	2
4	14266	PIN, M10 X 16 DOWEL	2
5	14276	TENSIONER, CAM CHAIN - 150CC	1
6	14275	GASKET, CAM CHAIN TENSIONER - 150CC	1
7	14274	ASM, CAM CHAIN TENSIONER - 150CC	1

NOTE: parts denoted as left or right hand are from driver's point of view.

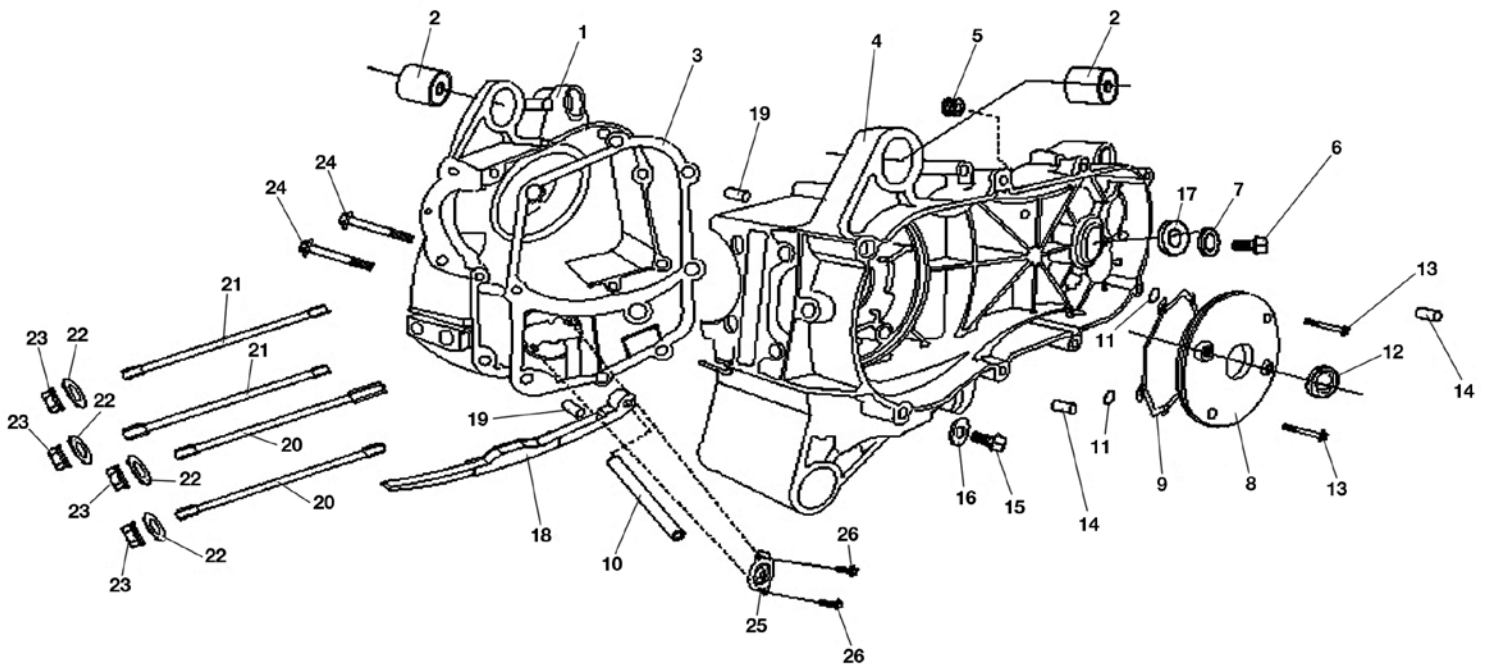

* ASW determined that it is more cost effective due to labor to replace the entire engine if this part is needed. Once this determination was made, ASW stopped ordering this part as a replacement item and are now sold out.

Ref#	Part#	Description	Qty
1	14277	(OUT OF STOCK)* HOUSING, CRANKCASE RH	1
2	14278	BUSHING, ENGINE HANGER - 150CC	2
3	14279	GASKET, CRANKCASE - 150CC	1
4	14280	HOUSING, CRANKCASE LH - 150CC	1
5	14558	GROMMET	1
6	14281	BOLT, M10 X 1.25 X 15 FHCS ZN	1
7	14282	WASHER, M10.2 X 18 X 1.3 FLAT	1
8	14283	COVER, SMALL LEFT - 150CC	1
9	14284	O-RING, M108 X 2	1
10	14559	PIN	1
11	14285	O-RING, M6 X 1.8	2
12	50104	OIL SEAL 19.8 X 30 X 5	1
13	14286	BOLT, M6 X 1.00 X 18 FHCS ZN	4

Ref#	Part#	Description	Qty
14	14287	PIN, M10 X 14 DOWEL	2
15	14288	BOLT, M12 X 1.5 SPECIAL - 150CC	1
16	14690	WASHER, M12 DAC	2
17	14290	SEAL, M20 X 32 X 6	2
18	14883	GUIDE, CAM CHAIN - 150CC	1
19	50016	PIN DOWEL SPECIAL 8 X 14	2
20	14291	STUD, M8 X 1.25 X 195.5	2
21	14292	STUD, M8 X 1.25 X 187.5	2
22	14293	WASHER, M8 FLAT ZN	4
23	14294	NUT, M8 X 1.25 FLANGE HEAD	4
24	14295	BOLT, M6 X 1.00 X 50 FHCS ZN	2
25	14501	SPACER, OIL - 150CC	1
26	14296	BOLT, M6 X 1.00 X 12 FHCS ZN	2

NOTE: parts denoted as left or right hand are from driver's point of view.

200 SERIES LUTV SECTION 4 TRANSMISSION

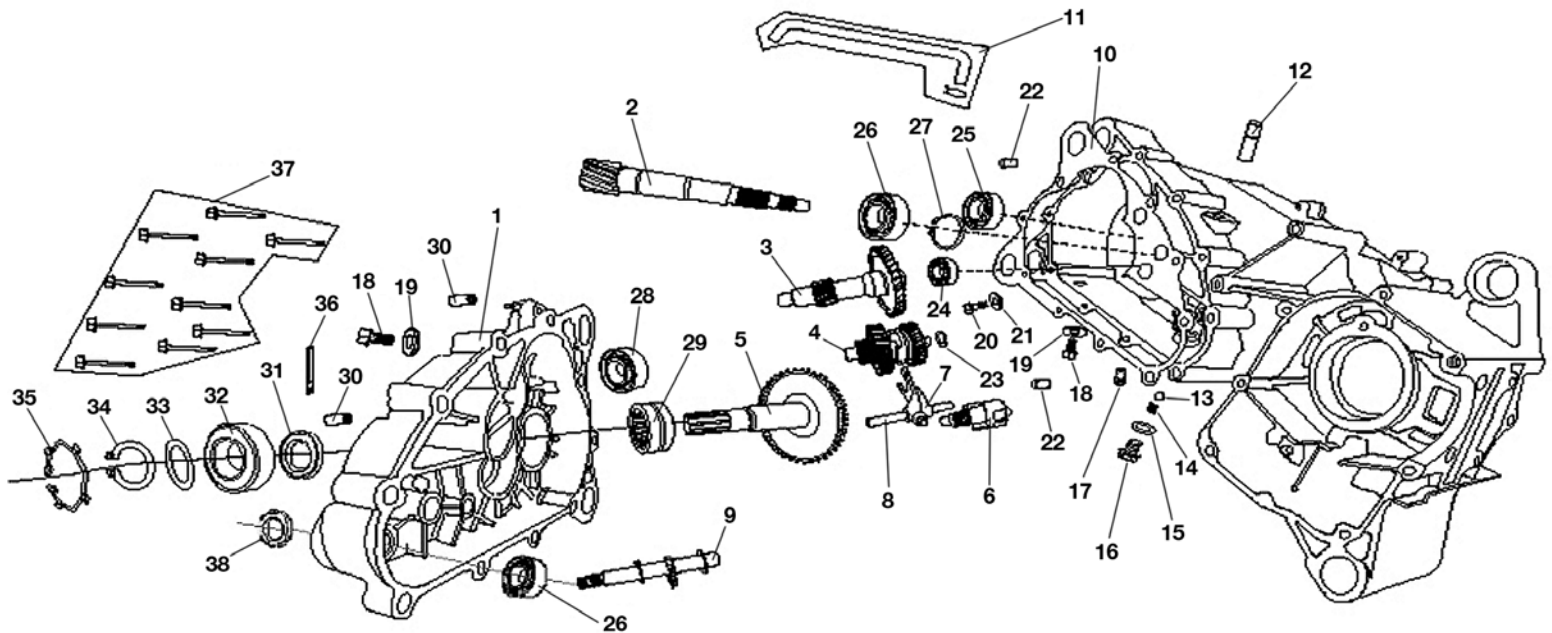

Ref#	Part#	Description	Qty
1	14297	HOUSING, OUTER TRANSMISSION - 150CC	1
2	14298	GEAR, PRI DRIVE - 150CC	1
3	14299	GEAR, SEC DRIVE - 150CC	1
4	14300	ASM, SHIFT GEAR CLUSTER D/N/R - 150CC	1
5	14841	GEAR, FINAL DRIVE SHAFT - 150CC	1
6	14302	ASM, SHIFT SELECTOR - 150CC	1
7	14303	PAWL, SHIFT SELECTOR - 150CC	1
8	14304	ROD, SHIFT PAWL - 150CC	1
9	14305	SHAFT, SHIFTER CAM - 150CC	1
10	14306	GASKET, TRANSMISSION CASE - 150CC	1
11	14307	TUBE, TRANSMISSION VENT - 150CC	1
12	14308	NIPPLE, VENT TUBE - 150CC LARGE	1
13	14309	BALL, SHIFT INDENT - 150CC	1
14	14310	SPRING, SHIFT INDENT - 150CC	1
15	14311	GASKET, SHIFT INDENT - 150CC	1
16	14312	BOLT, SHIFT INDENT - 150CC	1
17	14502	NIPPLE, VENT TUBE - 150CC SMALL	1
18	14313	BOLT, DRAIN/FILL PLUG - 150CC	2
19	14314	GASKET, TRANS DRAIN PLUG - 150CC	2

Ref#	Part#	Description	Qty
20	14296	BOLT, M6 X 1.00 X 12 FHCS ZN	2
21	14315	WASHER, M6 FLAT	2
22	14287	PIN, M10 X 14 DOWEL	2
23	14316	SPACER, M15 INNER GEAR - 150CC	1
24	14149	BEARING, OUTER - 6202-Z	1
25	50102	BEARING BALL RADIAL 6203	1
26	14146	BEARING, INNER - 6204-Z	1
27	14106	CIRCLIP, M20	1
28	14503	BEARING, 6302 15 X 42 X 13	1
29	14504	BEARING, RNA4905 30 X 42 X 17	1
30	14505	BUSHING, SHOCK ABSORBING - 150CC	2
31	14318	SEAL, M30 X 40 X 6	1
32	14598	BEARING, SEALED 6205 - 150CC	1
33	14511	WASHER, M22 X 31 X 2.5 FLAT	1
34	14319	CIRCLIP, M25	1
35	14320	CIRCLIP, M52	1
36	14321	CLAMP, WIRE - 150CC	1
37	14235	BOLT, M6 X 1.00 X 40 FHCS ZN	10
38	14597	OIL SEAL, SHIFTER CAM - 150CC	1

NOTE: parts denoted as left or right hand are from driver's point of view.

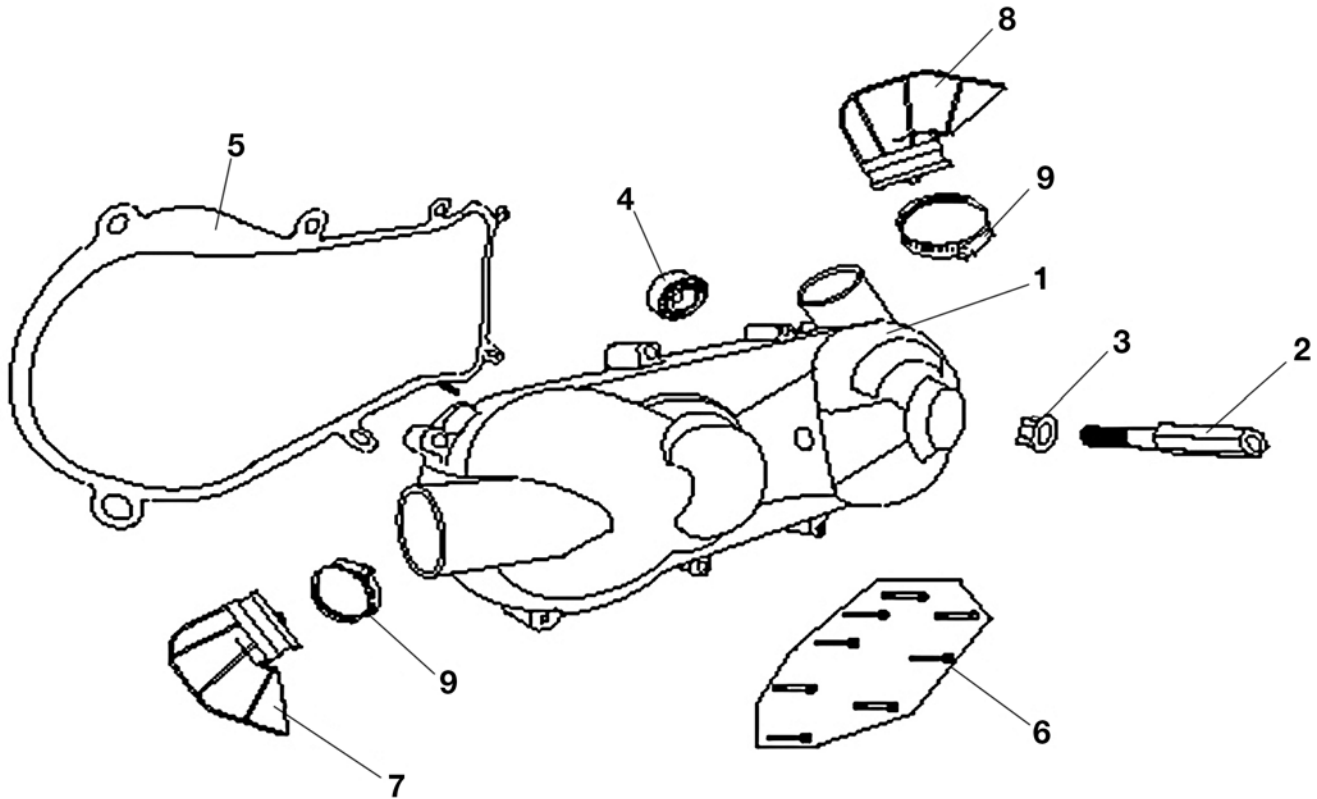

Ref#	Part#	Description	Qty
1	14323	COVER, CVT - 150CC	1
2	14507	BRACKET, EXHAUST - 150CC	1
3	14324	NUT, M12 X 1.25 LOCKING FLANGE ZN	1
4	14508	BEARING, 6200 10 X 30 X 9	2
5	14325	GASKET, CVT COVER - 150CC	1
6	14235	BOLT, M6 X 1.00 X 40 FHCS ZN	8
7	14322	SNORKEL, CVT - 150CC	1
8	14322	SNORKEL, CVT - 150CC	1
9	14509	CLAMP, SNORKEL - 150CC	2

NOTE: parts denoted as left or right hand are from driver's point of view.

200 SERIES LUTV SECTION 6 OUTER CRANKCASE ASSEMBLY

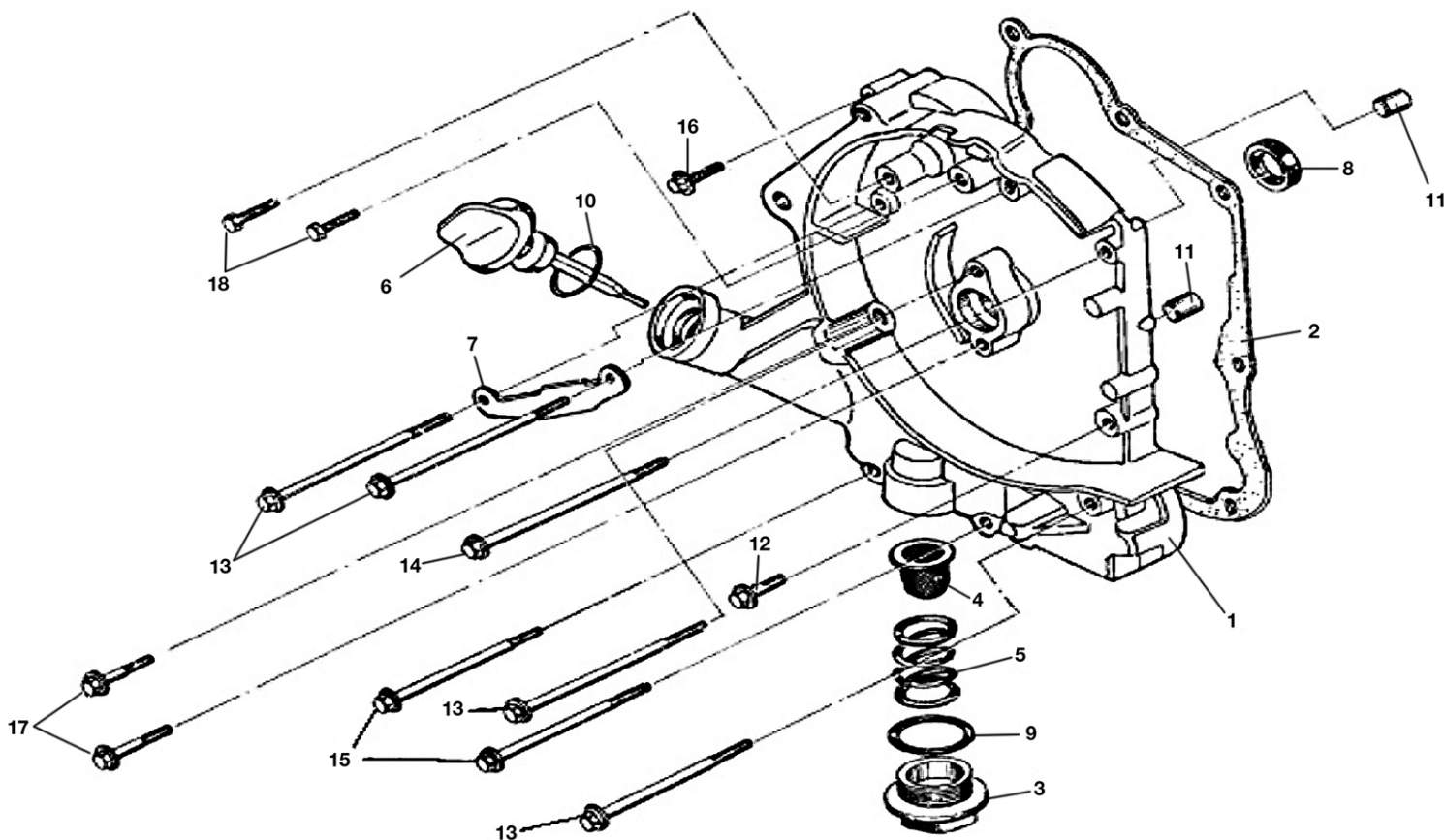

Ref#	Part#	Description	Qty
1	14326	COVER, OUTER CRANKCASE RH - 150CC	1
2	14327	GASKET, OUTER CRANKCASE - 150CC	1
3	14328	CAP, OIL DRAIN - 150CC	1
4	14329	SCREEN, OIL FILTER - 150CC	1
5	14330	SPRING, OIL FILTER SCREEN - 150CC	1
6	14331	DIPSTICK, OIL FILL - 150CC	1
7	14332	CLAMP, AC GENERATOR - 150CC	1
8	14333	SEAL, M19.8 X 30 X 5 OIL	1
9	14334	O-RING, M30.8 X 3	1
10	14335	O-RING, M18 X 3	1
11	50016	PIN DOWEL SPECIAL 8 X 14	2
12	14336	BOLT, M6 X 1.00 X 28 FHCS ZN	1
13	14337	BOLT, M6 X 1.00 X 95 FHCS ZN	4
14	14338	BOLT, M6 X 1.00 X 100 FHCS ZN	1
15	14339	BOLT, M6 X 1.00 X 110 FHCS ZN	2
16	14340	BOLT, M6 X 1.00 X 35 FHCS ZN	1
17	14341	BOLT, M6 X 1.00 X 20 FHCS ZN	2
18	14296	BOLT, M6 X 1.00 X 12 FHCS ZN	2

NOTE: parts denoted as left or right hand are from driver's point of view.

200 SERIES LUTV SECTION 7 PISTON, CRANK AND CONNECTING ROD

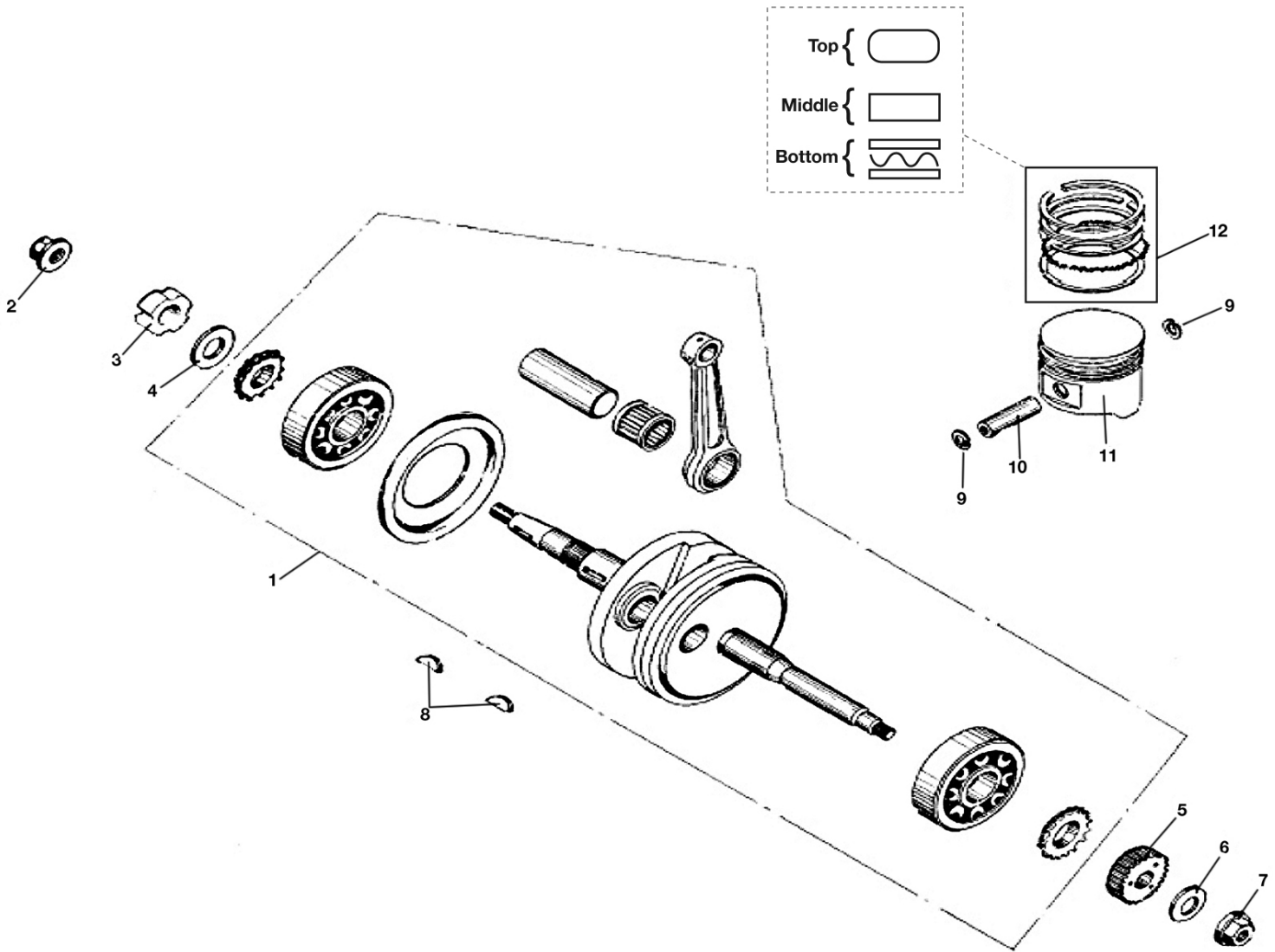

Ref#	Part#	Description	Qty
1	N/A	ASM, CRANK - CON ROD - 150CC	1
2	14324	NUT, M12 X 1.25 LOCKING FLANGE ZN	1
3	14510	NUT, M22 X 1.00 SPANNING - 150CC	1
4	14511	WASHER, M22 X 31 X 2.5 FLAT	1
5	14344	GEAR, KICK DRIVE - 150CC	1
6	14690	WASHER, M12 DAC	1
7	14324	NUT, M12 X 1.25 LOCKING FLANGE ZN	1
8	14512	KEY, WOODRUFF M4 X 14	1
9	14345	CLIP, PISTON RETAINING - 150CC	2
10	14346	PIN, PISTON WRIST - 150CC	1
11	14347	PISTON - 150CC	1
12	14348	KIT, PISTON RING - 150CC	1

NOTE: parts denoted as left or right hand are from driver's point of view.

200 SERIES LUTV SECTION 8 CAMSHAFT ASSEMBLY

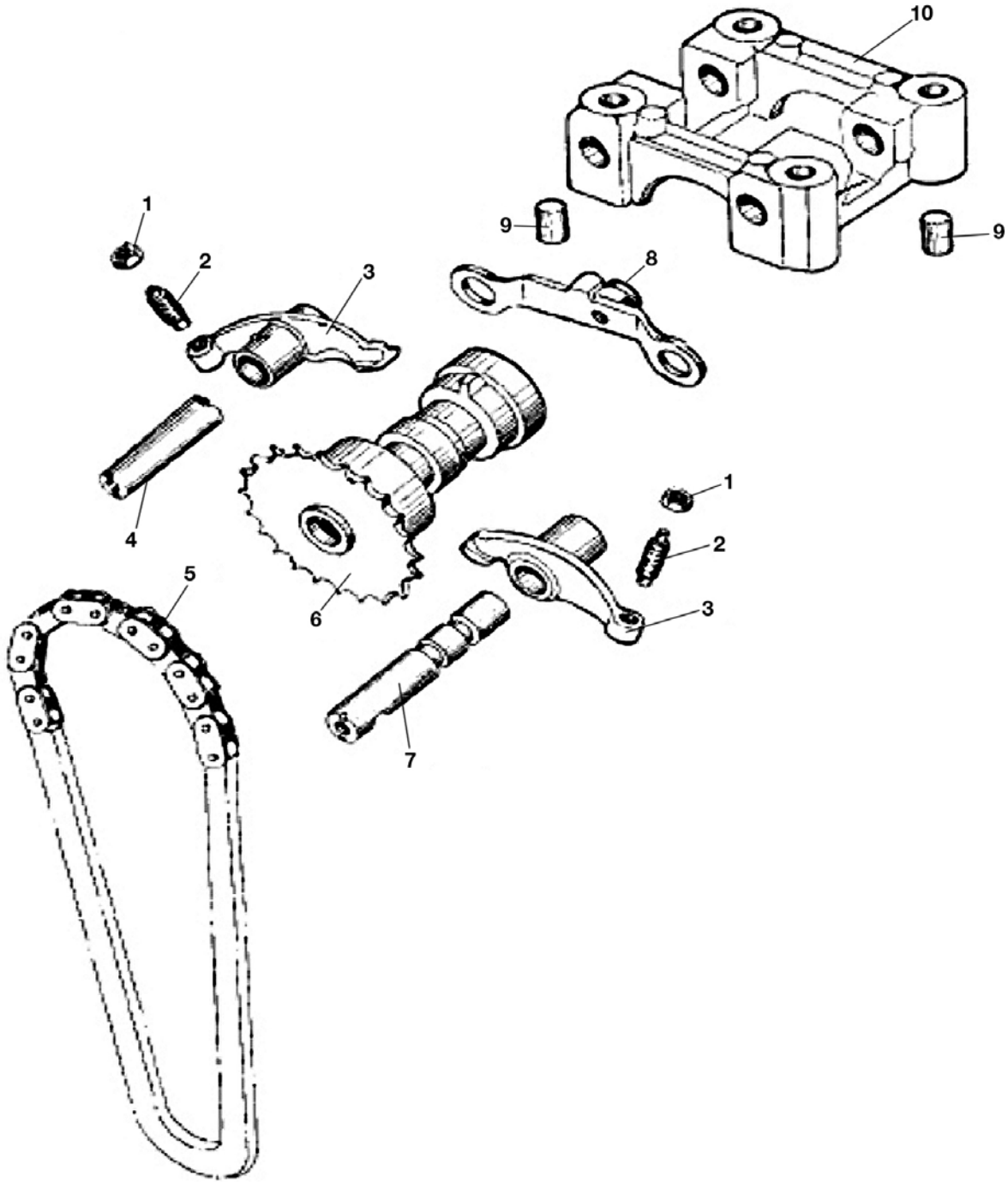

Ref#	Part#	Description	Qty
1	14513	NUT, M5 X 0.5 HEX	2
2	14349	SCREW, TAPPET ADJ - 150CC	2
3	14350	ARM, VALVE ROCKER - 150CC	2
4	14351	SHAFT, EXHAUST ROCKER ARM - 150CC	1
5	14352	CHAIN, CAMSHAFT - 150CC	1
6	14353	CAMSHAFT - 150CC	1
7	14354	SHAFT, INTAKE ROCKER ARM - 150CC	1
8	14355	PLATE, STOP - 150CC	1
9	14266	PIN, M10 X 16 DOWEL	2
10	14356	CAP, CAMSHAFT BRG - 150CC	1

NOTE: parts denoted as left or right hand are from driver's point of view.

200 SERIES LUTV SECTION 9 OIL PUMP ASSEMBLY

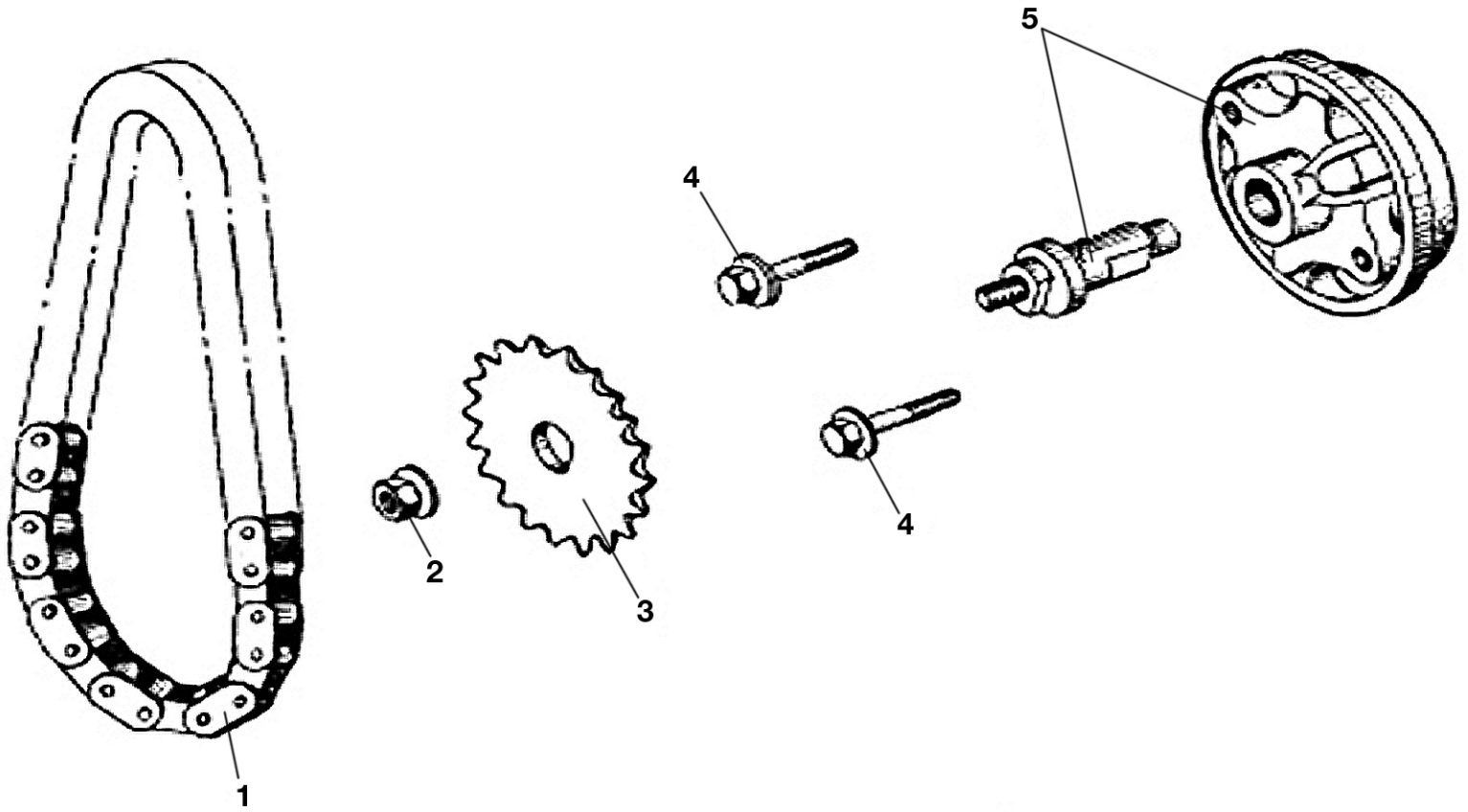

Ref#	Part#	Description	Qty
1	14357	CHAIN, OIL PUMP - 150CC	1
2	14358	NUT, M6 X 1.00 HEX FLANGE	1
3	14359	SPROCKET, OIL PUMP - 150CC	1
4	14360	BOLT, M6 X 1.00 X 30 FHCS ZN	2
5	14361	ASM, OIL PUMP - 150CC	1

NOTE: parts denoted as left or right hand are from driver's point of view.

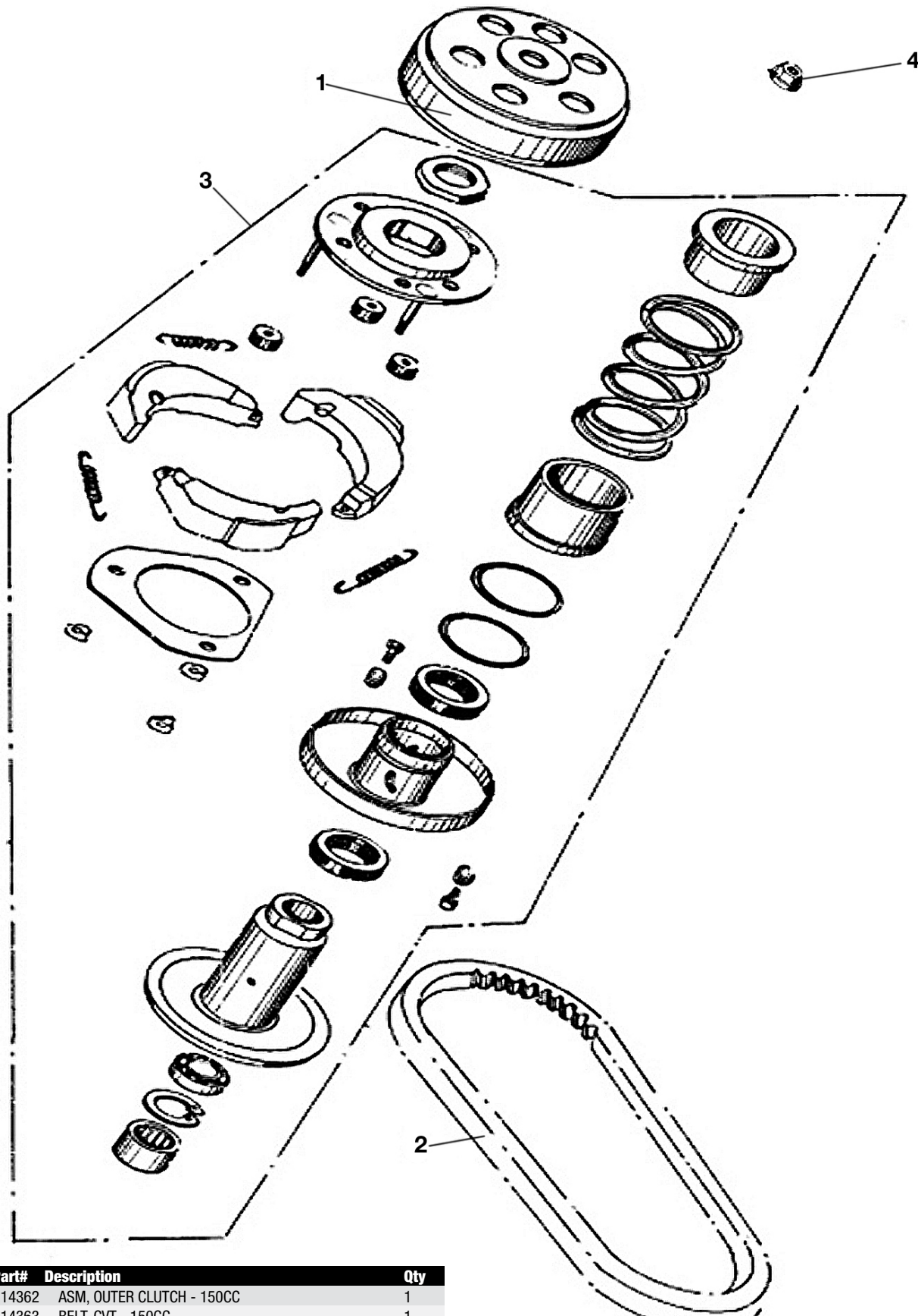

Ref#	Part#	Description	Qty
1	14362	ASM, OUTER CLUTCH - 150CC	1
2	14363	BELT, CVT - 150CC	1
3	14364	ASM, DRIVEN PULLEY - 150CC	1
4	15164	NUT, M12X1.25 LF THIN	1

NOTE: parts denoted as left or right hand are from driver's point of view.

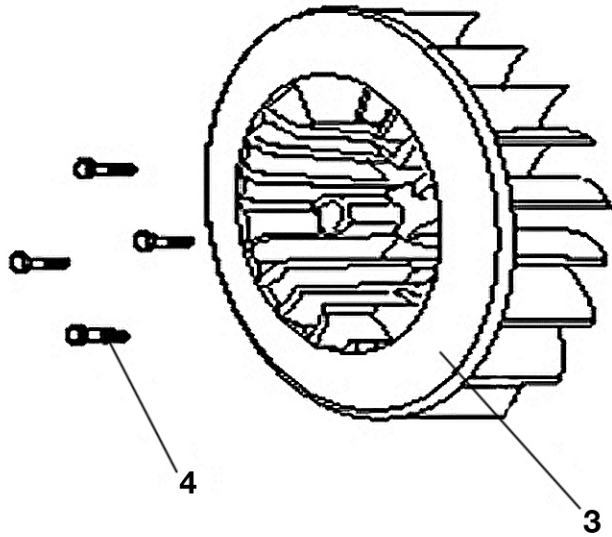
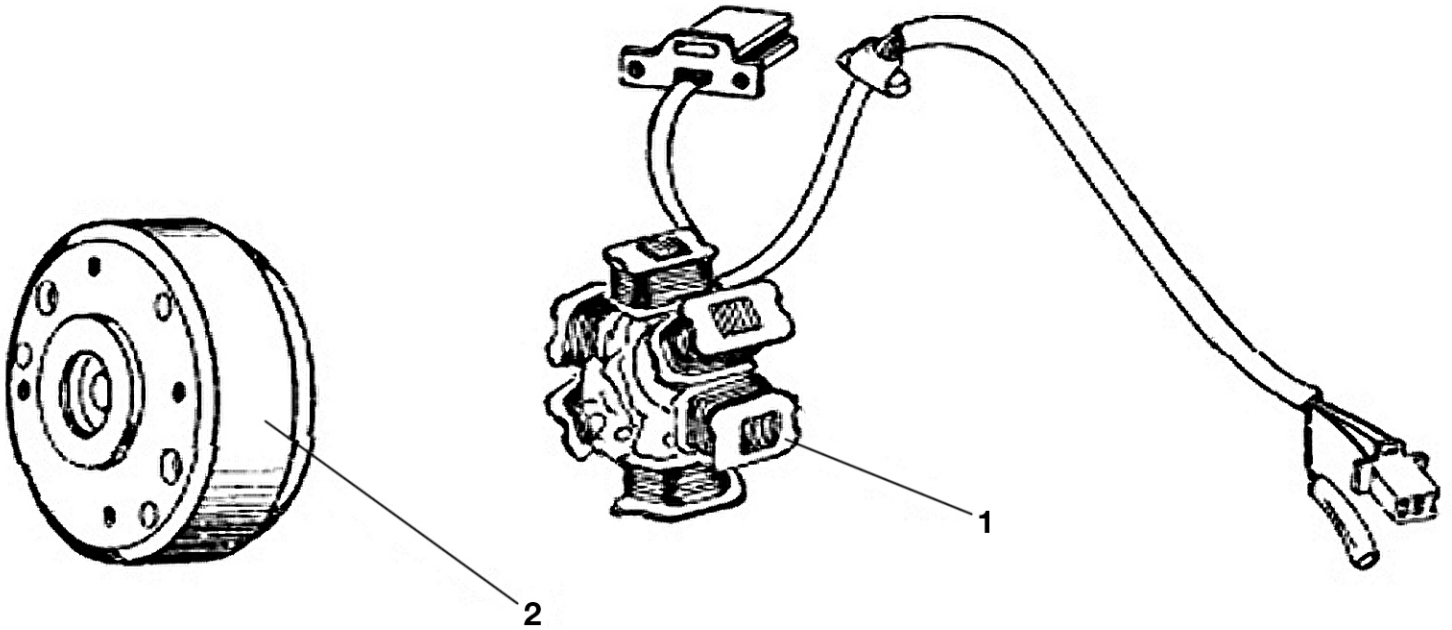

Ref#	Part#	Description	Qty
1	15120	MAGNETO, 150CC H0	1
2	14366	FLYWHEEL - 150CC	1
3	14367	FAN, COOLING - 150CC	1
4	14368	BOLT, M6 X 1.00 X 15 FHCS ZN	4

NOTE: parts denoted as left or right hand are from driver's point of view.

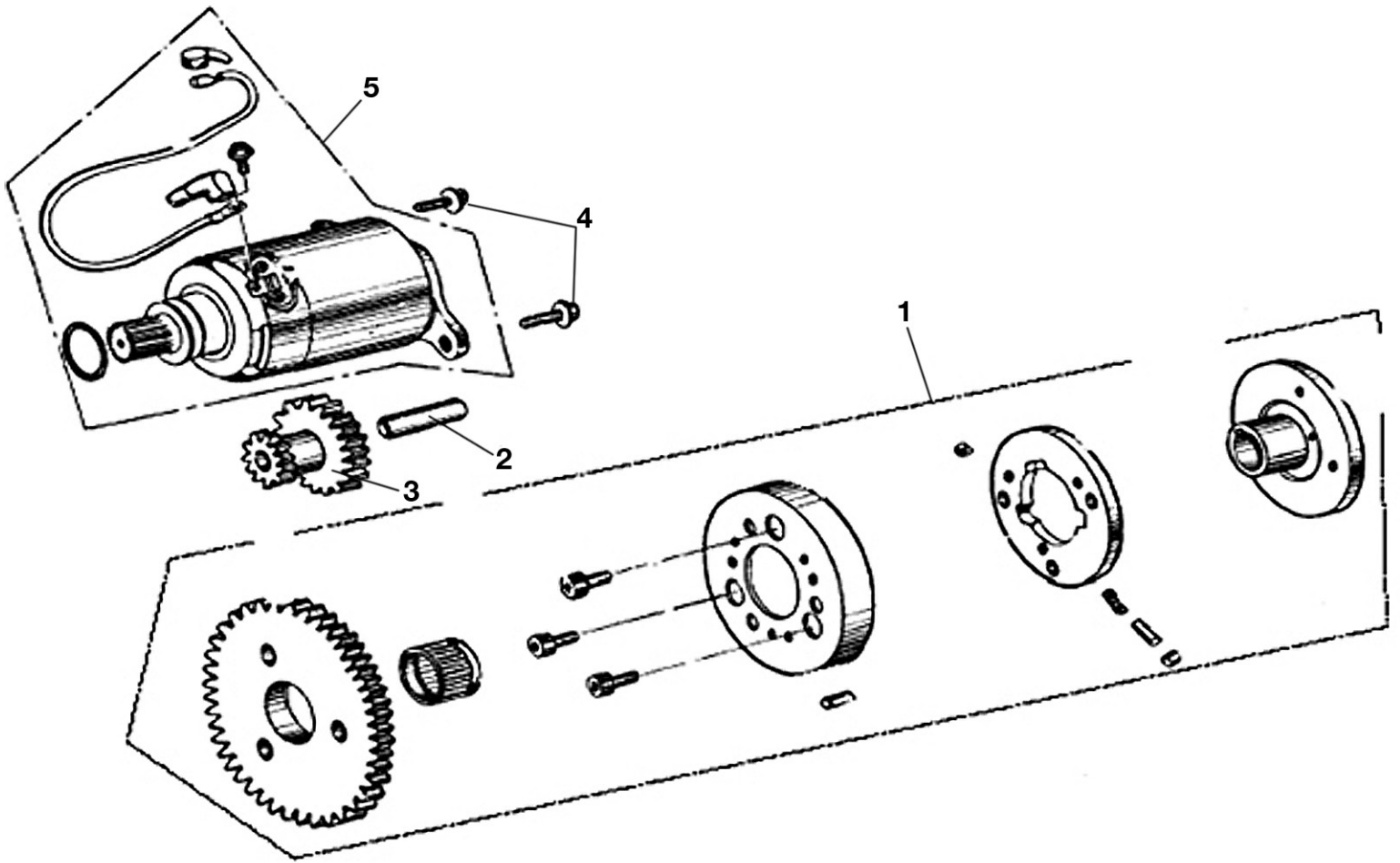

Ref#	Part#	Description	Qty
1	14369	ASM, STARTER CLUTCH - 150CC	1
2	14370	SHAFT, STARTER RED - 150CC	1
3	14371	GEAR, STARTER RED - 150CC	1
4	14372	BOLT, M6 X 1.00 X 16 FHCS ZN	2
5	14373	ASM, STARTER MOTOR - 150CC	1

NOTE: parts denoted as left or right hand are from driver's point of view.

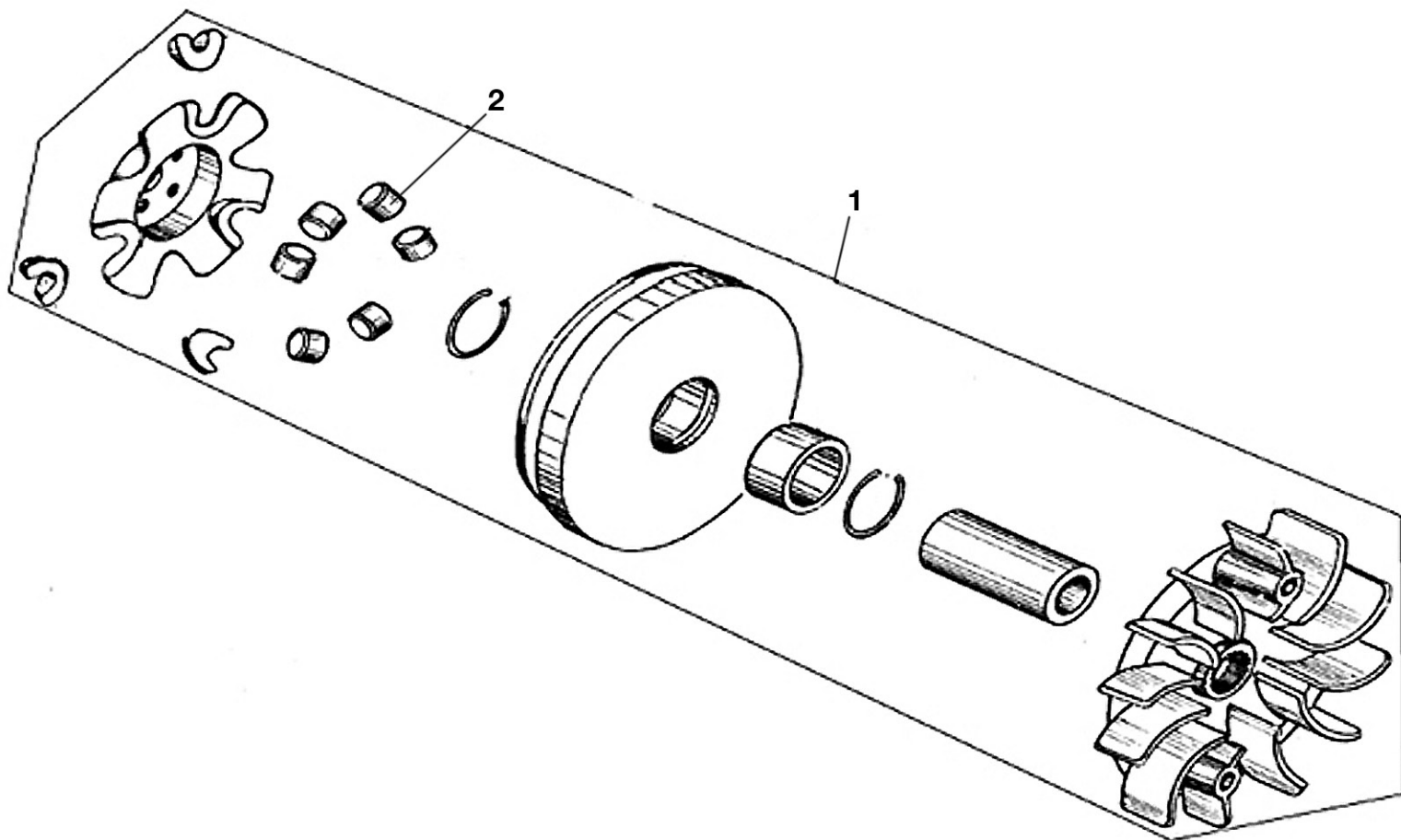

Ref#	Part#	Description	Qty
1	14374	ASM, DRIVER PULLEY - 150CC	1
2	14375	WEIGHT, DRIVER PULLEY - 150CC	6

NOTE: parts denoted as left or right hand are from driver's point of view.

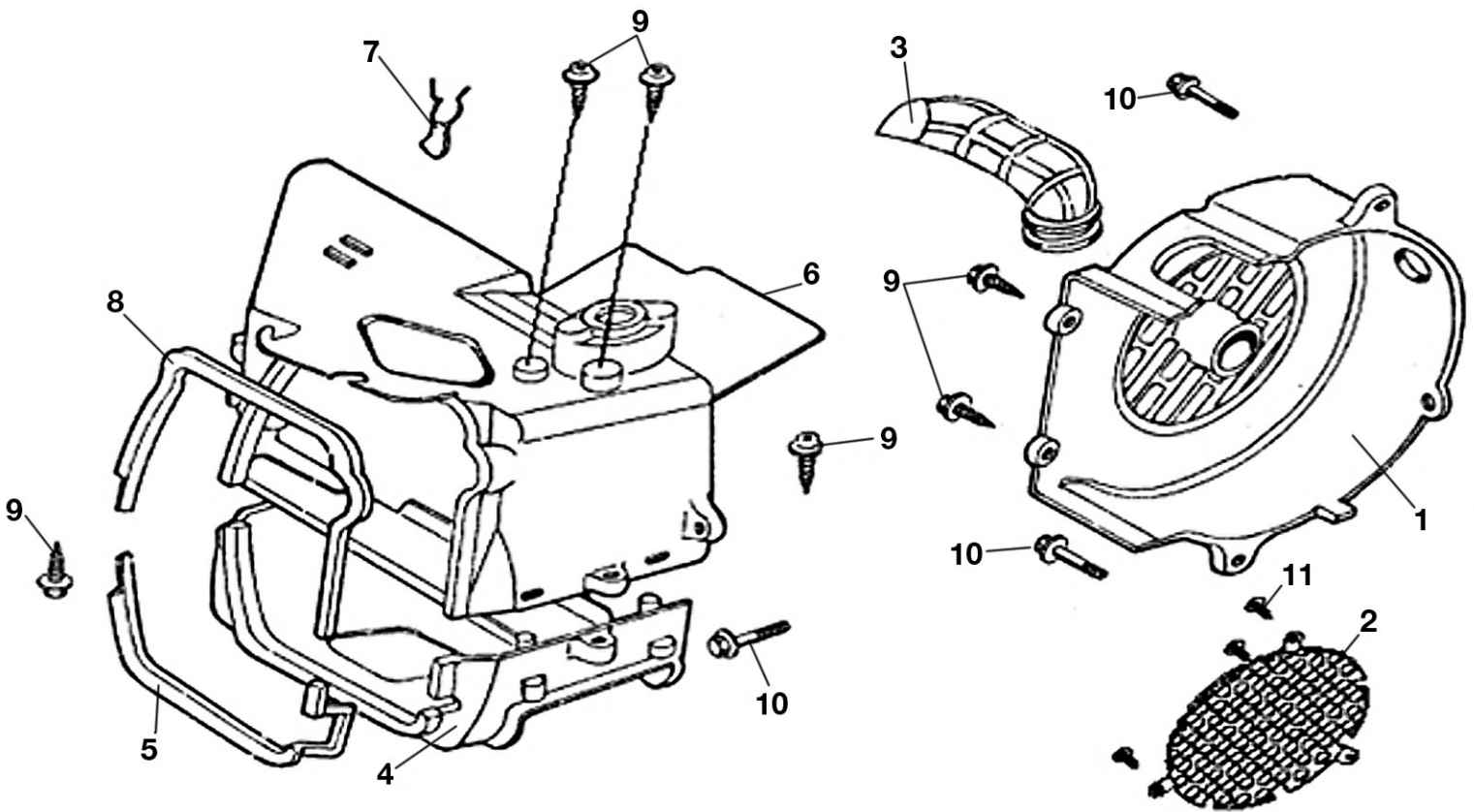

Ref#	Part#	Description	Qty
1	14540	COVER, FAN COMP - 150CC	1
2	14541	COVER, DUST - 150CC	1
3	14542	DUCT, CARBURETOR COOLING - 150CC	1
4	14543	SHROUD, LOWER - 150CC	1
5	14544	SEAL, LOWER SHROUD - 150CC	1
6	14545	SHROUD, UPPER - 150CC	1
7	14546	CLIP, CORD - 150CC	1
8	14547	SEAL, UPPER SHROUD - 150CC	1
9	50065	SCREW TAPPING	6
10	14286	BOLT FLANGE SH 6 X 18	3
11	14539	SCREW, 3.5 X 13 STFH	3

NOTE: parts denoted as left or right hand are from driver's point of view.

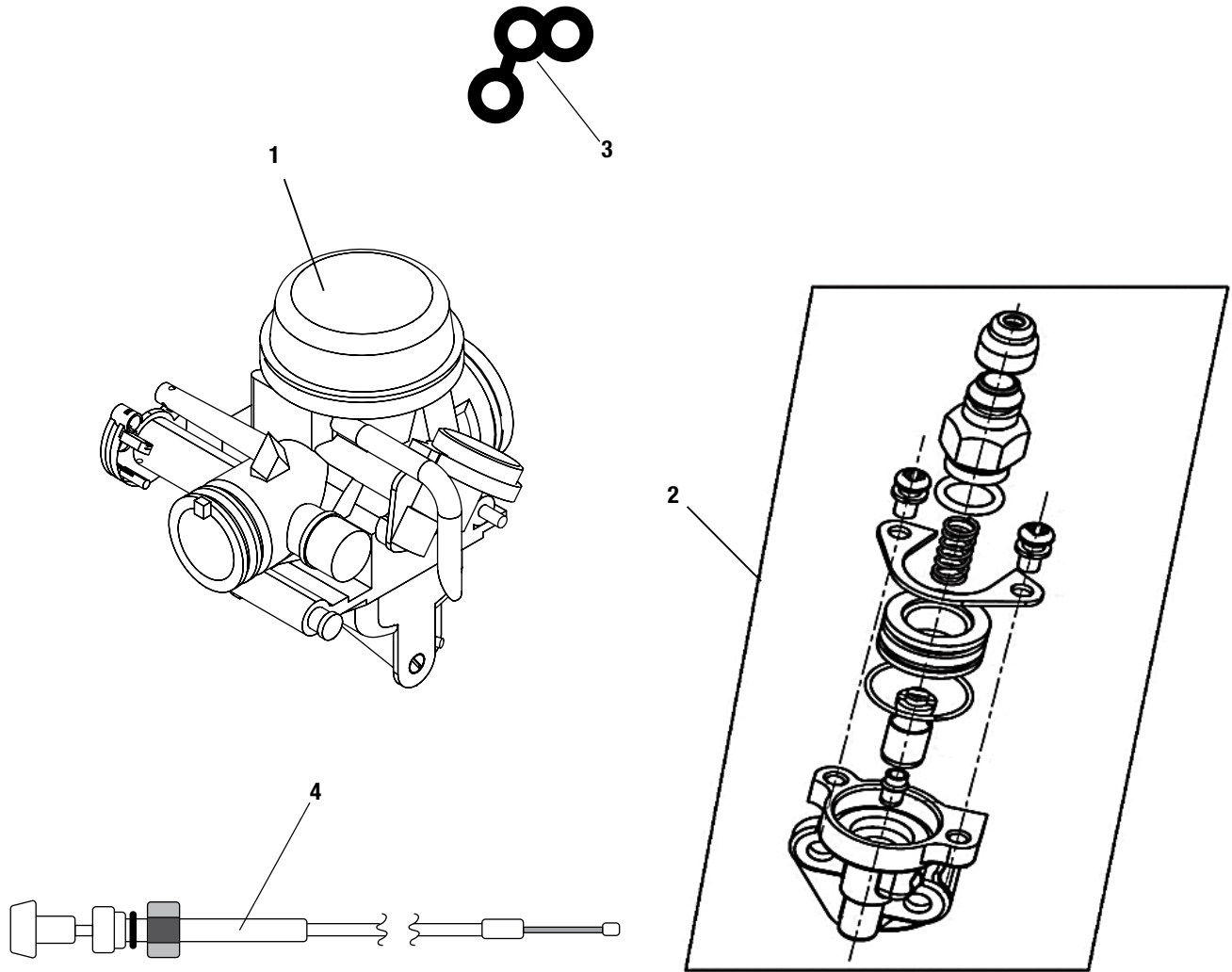

Ref#	Part#	Description	Qty
1	15856	ASM, CARB W/ MANUAL CHOKE - 150CC - DENI	1
2	15458	ASM, MANUAL ENRICHER / CHOKE	1
3	15460	O-RING, SPECIAL: CARB ENRICHER	1
4	15430	CABLE, CHOKE 3050 MM LONG	1

NOTE: parts denoted as left or right hand are from driver's point of view.

REFERENCE LIST
ON NEXT PAGE

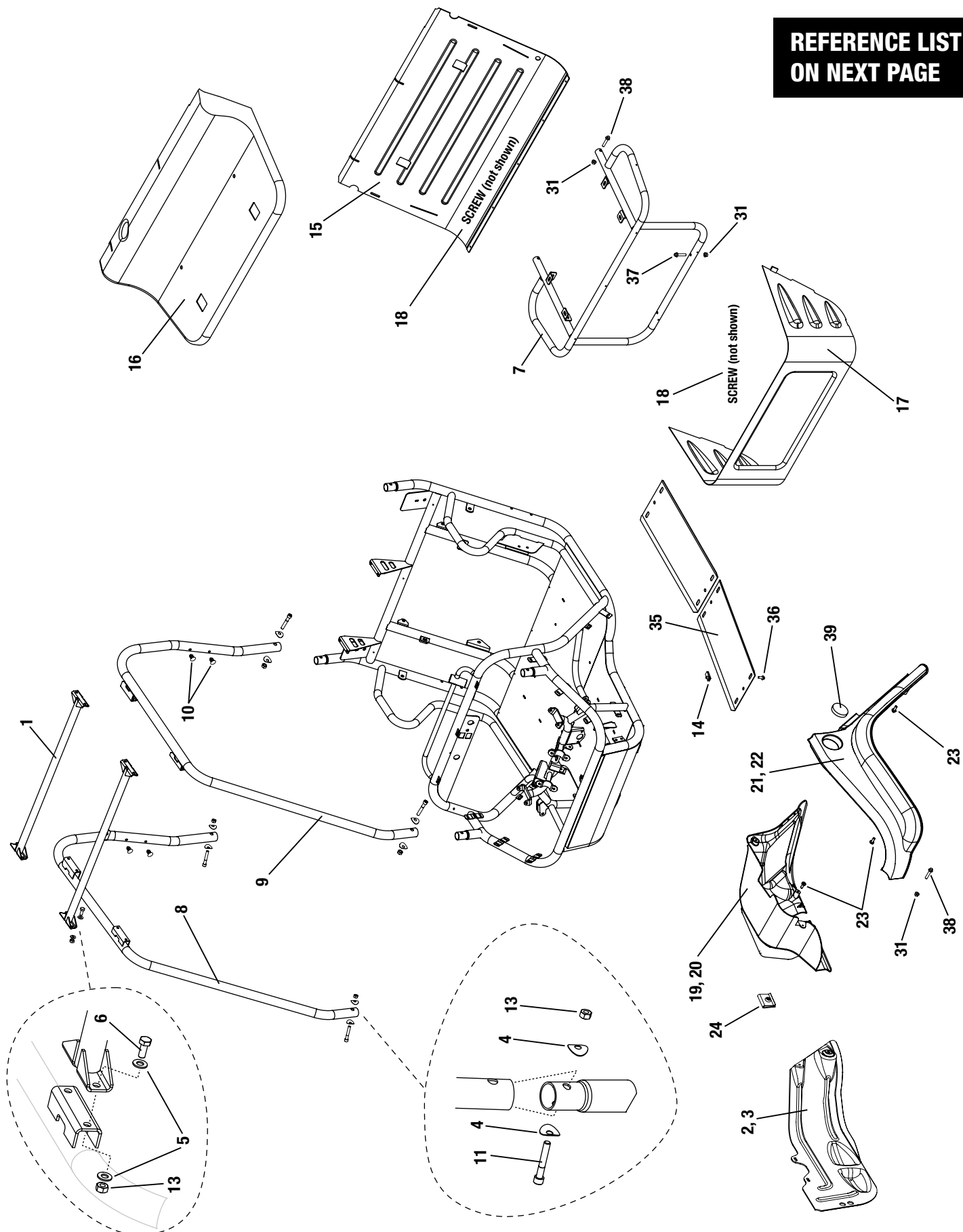

NOTE: parts denoted as left or right hand are from driver's point of view.

200 SERIES LUTV SECTION 16 FRAME GROUP (continued)

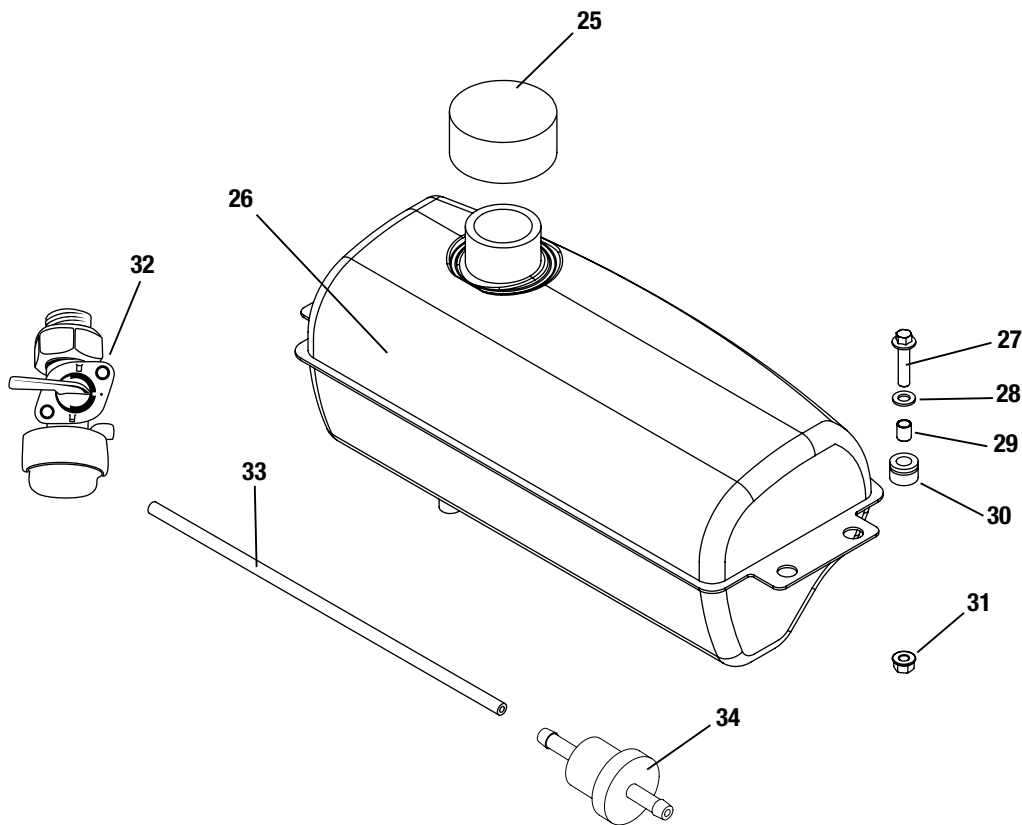

Ref#	Part#	Description	Qty
1	15637-2	BAR, OH CROSS - 202 BLK	2
2	15658	PAN, LH LOWER KICK - 202	1
3	15659	PAN, RH LOWER KICK - 202	1
4	2-50702	WASHER, 5/16IN TUBE FIT (BENT)	8
5	15836	WASHER, 5/16" SAE FLAT- BLK	16
6	15837	BOLT, 5/16"-18 X .75" HHCS BLK	8
7	15694-2	FRAME, SEAT SPPT - 202 BLK	1
8	15644-2	BAR, OH MAIN - RH - 202 BLK	1
9	15643-2	BAR, OH MAIN - LH - 202 BLK	1
10	15778	PLUG, HOLE DIAMETER 8MM - PLASTIC PUSH	8
11	2-50172	BOLT, 5/16IN X 2IN SOCKET HEAD	4
13	15775	NUT, 5/16"-18 HEX CENTERLOCK	12
14	15823	NUT, CLIP ON TAPPED - M6 X 1.0; 11 GA MATERIAL	8
15	15679	PANEL, BACKSPLASH - 202	1
16	15680	COVER, TOP SEAT TUB - 202	1
17	15678	SURROUND, SEAT TUB - 202	1
18	2-50630	SCREW, #10 X 3/4IN HEX WASHER TEK	16
19	14874	WHEEL WELL, INNER RH	1
20	14875	WHEEL WELL, INNER LH	1

Ref#	Part#	Description	Qty
21	14878	FENDER FLARE, RH	1
22	14879	FENDER FLARE, LH	1
23	15821	SCREW, #10 X .75", HEX FLANGE HEAD	18
24	15958	NUT, "U" CLIP - #10 SCREW, 12 GA MATERIAL	8
25	13871	CAP, FUEL - 6150/7150	1
26	14161-2	FUEL TANK	1
27	15779	BOLT, M8 X 1.25 X 35 FHCS	4
28	2-50704	WASHER, 5/16IN USS FLAT	4
29	14162	SPACER, FUEL TANK	4
30	14163	BUSHING, FUEL TANK MOUNT	4
31	14088	NUT, M8 X 1.25 FLANGE TOP LOCK	10
32	15454	VALVE, FUEL MANUAL ON/OFF/RES W/ O-RING	1
33	15838	LINE, FUEL - 12" WITH (2) CLAMPS	2
34	14167	FILTER, FUEL	1
35	15805	SHIELD, CABLE TRAY - 202	2
36	14426	BOLT, M6 X 1.00 X 14 FHCS	8
37	14439	BOLT, M8 X 1.25 X 40 FHCS DAC	2
38	14436	BOLT, M8 X 1.25 X 30 FHCS DAC	4
39	14784	REFLECTOR, 54.9 MM - AMBER	2

NOTE: parts denoted as left or right hand are from driver's point of view.

200 SERIES LUTV SECTION 16 FRAME GROUP (continued)

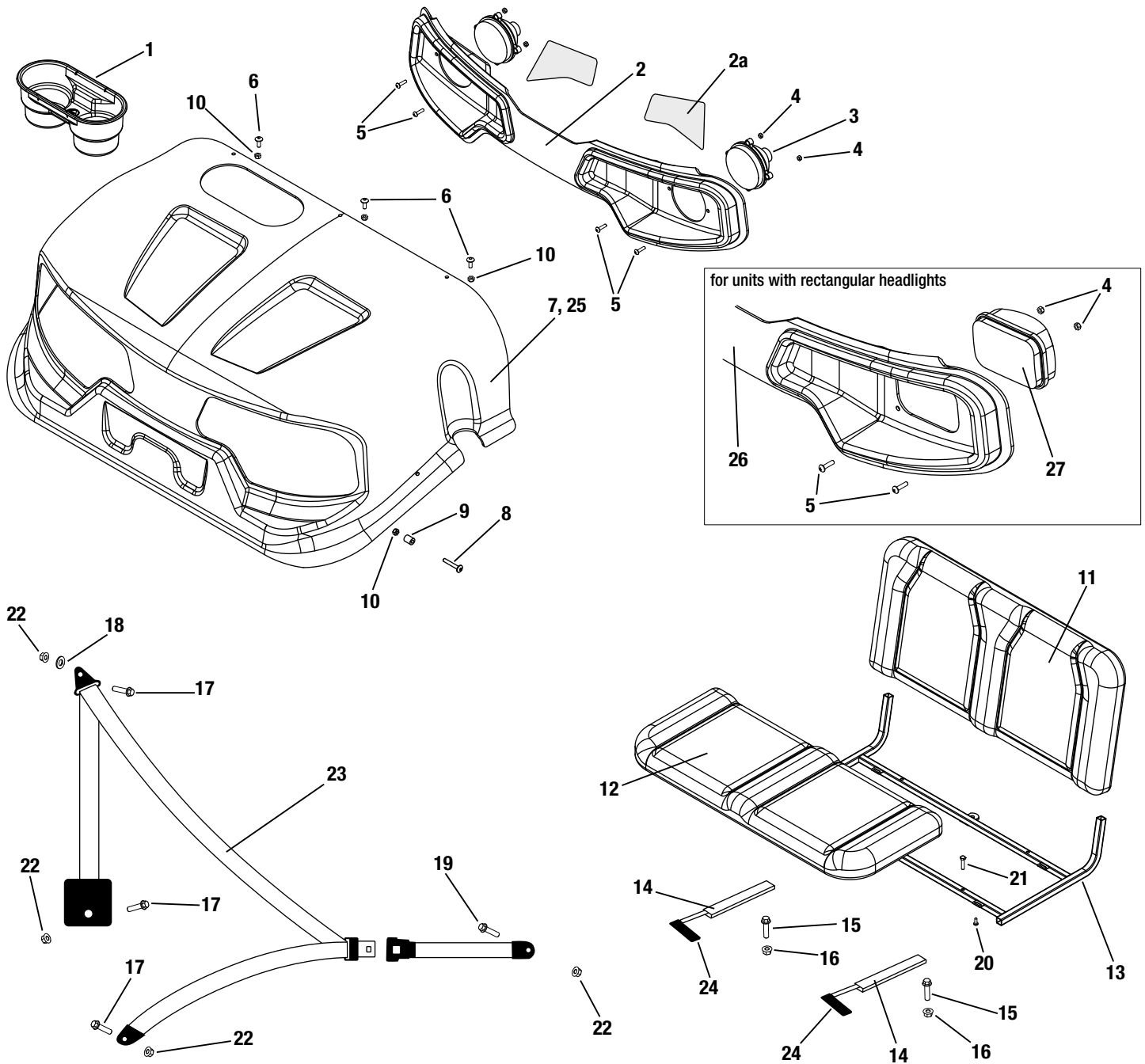

Not Shown:

- 2-70127 HEAD LIGHT 862 BULB-REPLACEMENT #4831180 2
- 15256 SEAT BELT SHOULDER CAP 2

Ref#	Part#	Description	Qty
1	14842	CUP HOLDER - 200S	1
2	15647	BEZEL, HEADLIGHT ROUND	1
2a	15776	DECAL, FRONT REFLECTIVE-AMBER (SET OF 2)	1
3	15648	LIGHT, 3.5 SURF MOUNT - 25W	2
4	14491	NUT, M5 X .8 NYLOC ZN	4
5	15066	SCREW, M5 X 0.80 X 20 PH - BLK	4
6	15565	SCREW, M6-1.0 X 16 BUTTON HEAD SOCKET SS	3
7	15577	HOOD, RED 202 SERIES W/LIGHT	2
8	15566	SCREW, M6-1.0 X 40 BUTTON HEAD SOCKET SS	2
9	15762	SPACER, NYLON 1/2"OD X 1/4"ID X 5/8"L	2
10	14236	NUT, M6 X 1.00 NYLOC ZN	5
11	15522	CUSHION, SEAT BACK- BLACK - 200	1
12	15523	CUSHION, SEAT BASE- BLACK - 200	1
13	15691-2	FRAME, SEAT - 202 BLK	1

Ref#	Part#	Description	Qty
14	15624	SLIDE, SEAT WITH RELEASE HANDLE (PR)	1
15	15957	BOLT, 5/16"-18 X 1" SQUARE HEAD GRADE 5	2
16	14088	NUT, M8X1.25 FLANGE TOP LOCK	2
17	15829	BOLT, M12 X 1.75 X 25 FHCS	6
18	2-50794	WASHER, 7/16 USS FLAT	2
19	15830	BOLT, M12 X 1.75 X 30 FHCS	1
20	2-50609	SCREW, #14 X 3/4IN PAN HEAD-WOOD	5
21	14438	BOLT, M8 X 1.25 X 35 HHCS	4
22	15982	NUT, M12 X 1.75 FLANGE TOP LOCK	7
23	14786	SEATBELT, RETRACTABLE	2
24	14994	COVER, SEAT SLIDE HANDLE (BLK)	2
25	15585	HOOD, GRN 202 SERIES W/HEADLIGHT TRIM	1
26	15578	BEZEL, HEADLIGHT RECT - 202 SERIES	1
27	2-70133	LIGHT, UTV-RECTANGULAR (#0541172)	2

NOTE: parts denoted as left or right hand are from driver's point of view.

200 SERIES LUTV SECTION 17 STEERING & BRAKES

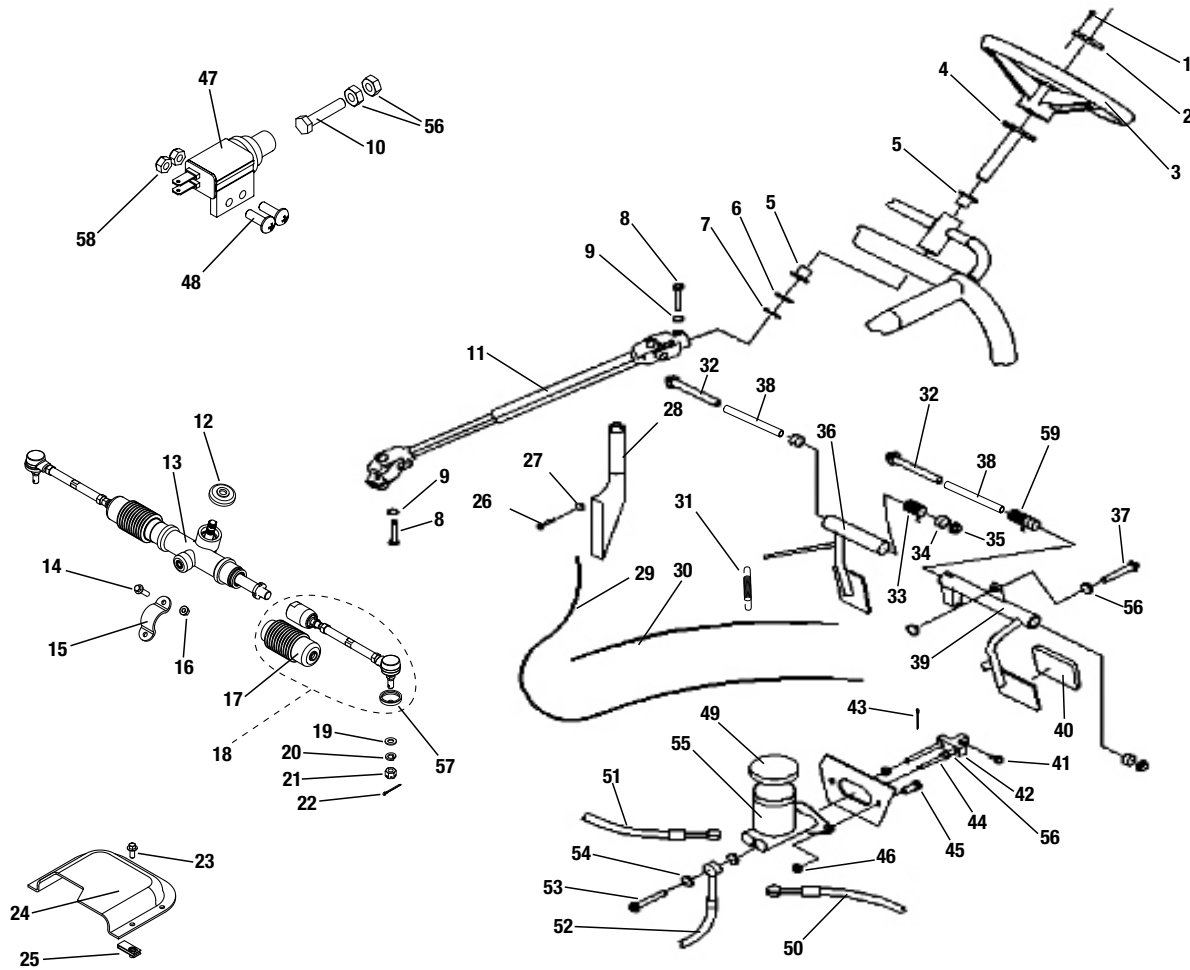

Ref#	Part#	Description	Qty
1	14894	BOLT, M6 X 1.0 X 14 SHCS - ZN	6
2	14846	CAP, STEERING WHEEL - 200S	1
3	14845	STEERING WHEEL - 200S	1
4	14847	SHAFT, STEERING - 200S	1
5	14104	BUSHING, FLANGED SLEEVE 20 X 28 X 24.1	2
6	14895	WASHER, M20 FLAT ZN	1
7	14106	CIRCLIP, M20	1
8	14437	BOLT, M8 X 1.25 X 25 HHCS ZN	2
9	14495	WASHER, M8 SPLIT LOCK ZN	2
10	14440	BOLT, M8 X 1.25 X 40 FT HHCS	1
11	14896	SHAFT, STEERING U-JOINT - 200 SERIES	1
12	14738	DUST SHEILD, R & P BLACK RUBBER - 7150	1
13	14848	ASM, RACK AND PINION - 200S	1
14	14436	BOLT, M8 X 1.25 X 25 FHCS ZN	4
15	14112	BRACKET, RACK AND PINION MNT	2
16	14088	NUT, M8 X 1.25 LOCKING FLANGE ZN	8
17	14109	BOOT, R&P BLACK RUBBER - 7150	2
18	14897	ASM, TIE ROD END - 200 SERIES	2
19	14240	WASHER, M10 FLAT ZN	2
20	14241	WASHER, M10 SPLIT LOCK ZN	2
21	14242	NUT, M10 X 1.25 CASTLE	2
22	15833	PIN, 3/32" x 1.25 COTTER	2
23	14426	BOLT, M6 X 1.00 X 14 FHCS ZN	5
24	14900	COVER, FLOOR BRAKE ACCESS - 200S	1
25	15823	NUT, CLIP ON TAPPED - M6 X 1.0; 11 GA MA	5
26	14426	BOLT, M6 X 1.00 X 14 FHCS ZN	2
27	14236	NUT, M6 X 1.00 NYLOC ZN	2
28	14849	HANDLE, PARK BRAKE - 200S	1
29	14850	CABLE, PARK BRAKE - 200S	1
30	14851	CABLE, THROTTLE - 200S	1

Ref#	Part#	Description	Qty
31	14852	SPRING, THROTTLE PEDAL - 200S	1
32	15959	BOLT, M8 X 1.25 X 145 HHCS	2
33	14113	SPRING, THROTTLE PEDAL - 7150	1
34	14119	BUSHING, SLEEVE 12 X 21 X 12	4
35	14088	NUT, M8 X 1.25 LOCKING FLANGE ZN	8
36	14853-2	PEDAL, THROTTLE - 201/202 - BLK	1
37	14439	BOLT, M8 X 1.25 X 40 FHCS ZN	2
38	15960	SPANNER, CONTROL PEDALS - 202	2
39	14854-2	PEDAL, BRAKE - 201/202 - BLK	1
40	2-70261	PAD, RUBBER-BRAKE	2
41	14116	PIN, M6 X 24 BRAKE BLOCK - 6150/7150	1
42	14101	T BLOCK, BRAKE - 7150	1
43	15832	PIN, 5/64" X .5 COTTER	1
44	14117	PUSHROD, BRAKE ADJUST - 7150	2
45	14438	BOLT, M8 X 1.25 X 35 HHCS ZN	2
46	14088	NUT, M8 X 1.25 LOCKING FLANGE ZN	2
47	15136	SWITCH, THROTTLE/BRAKE SAFETY	1
48	14453	BOLT, M5 X .8 X 15 PHMS DAC	2
49	14131	CAP, BRAKE MASTER CYL - 7150	1
50	15466	HOSE, HYD BRAKE - 26"	1
51	14129	HOSE, HYD BRAKE - 43"	1
52	14130	HOSE, HYD BRAKE - 75"	1
53	14460	BOLT, M10 X 24 BRAKE BANJO	3
54	14127	WASHER, BRASS BRAKE LINE	6
55	14121	ASM, MASTER CYLINDER - 7150	1
56	14610	NUT, M8 X 1.25 DAC	7
57	15316	BOOT, TIE ROD 150CC	2
58	14491	NUT, M5 X .8 NYLOC ZN	2
59	14120	SPRING, BRAKE PEDAL	1

NOTE: parts denoted as left or right hand are from driver's point of view.

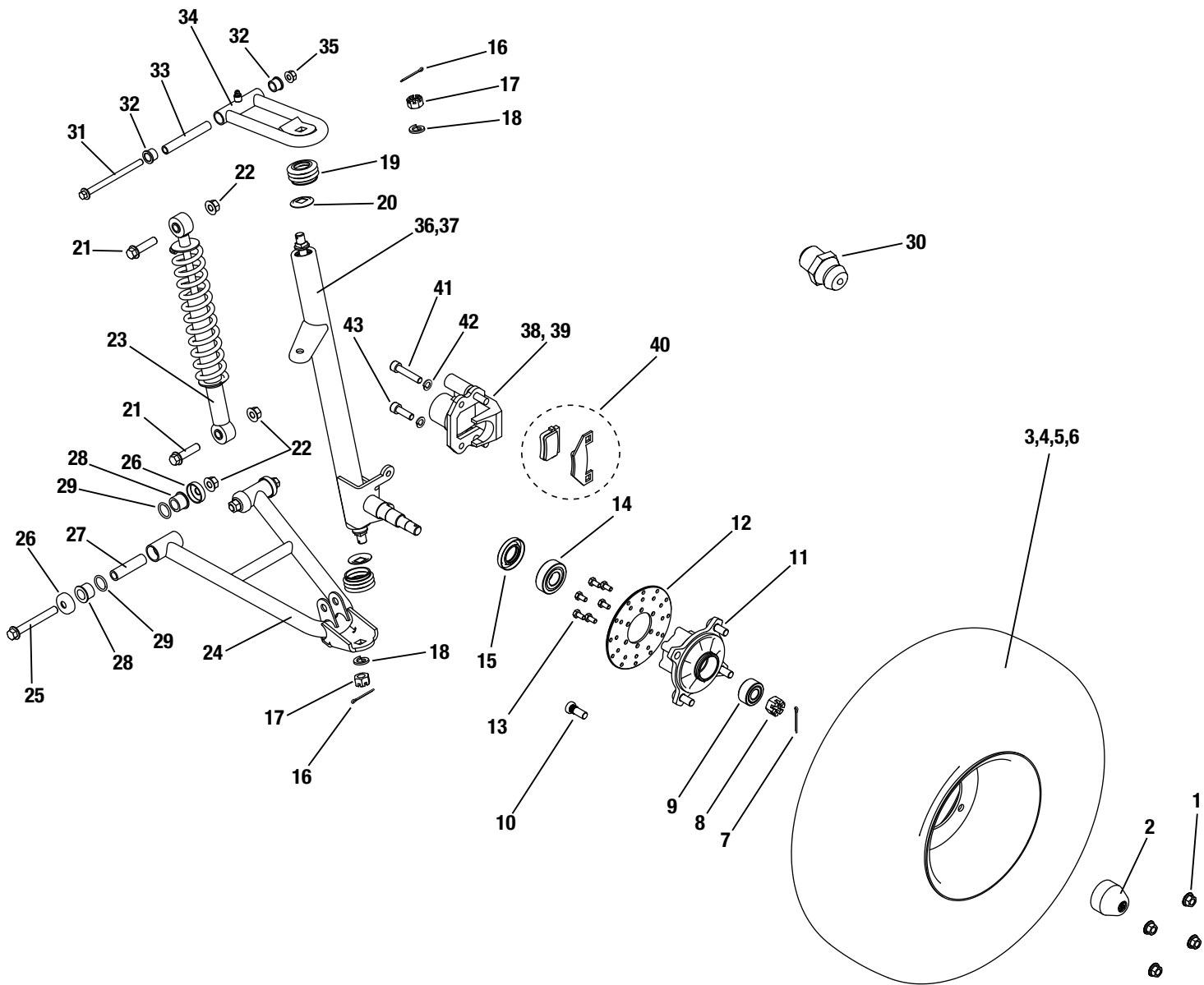

Ref#	Part#	Description	Qty
1	13979	NUT, M10 X 1.25 WF ZN	8
2	13930	CAP, RUBBER HUB NOSE	2
3	15670	ASM, 20X7-8 TIRE/WH RH - GBLK	1
4	15671	ASM, 20X7-8 TIRE/WH LH - GBLK	1
5	14813	TIRE, FRONT 20X7-8 - FAR EAST	2
6	15674	WHEEL, 8X5.5 - GBLK - 4-110	2
7	15833	PIN, 3/32" x 1.25 COTTER	2
8	14727	NUT, M14 X 1.5 CASTLE	2
9	15339	BEARING, OUTER - 3202-2RS	2
10	14147	STUD, M10 X 1.25 X 31 WHEEL	8
11	14148	HUB, FRONT WHEEL - 6150/7150	2
12	14144	DISC, FRONT BRAKE - 7150	2
13	15956	BOLT, M6 X 1.00 X 12 HHCS DAC	12
14	14146	BEARING, INNER - 6204-Z	2
15	14145	SEAL, M47 X 25 X 7 DUST	2
16	15833	PIN, 3/32" x 1.25 COTTER	2
17	14244	NUT, M12 X 1.25 CASTLE	2
18	14245	WASHER, M12 SPLIT LOCK ZN	2
19	14137	SEAL, BALL JOINT - 6150/7150	4
20	14138	SPACER, BALL JOINT HEAD - 6150/7150	4
21	15824	BOLT, M10 X 1.5 X 40 FHCS	4
22	15822	NUT, M10 X 1.5 FLANGE TOP LOCK	8

Ref#	Part#	Description	Qty
23	14796	SHOCK - RED & BLACK	2
24	14157-2	A ARM, LOWER - BLACK W/ZERK	2
25	15826	BOLT, M10 X 1.5 X 80 FHCS	4
26	14154	CAP, DUST - LWR SUSP ARM - 7150	8
27	14140	SPANNER, A ARM LOWER - 7150	4
28	14155	BUSHING, FLANGED SLEEVE 15 X 21 X 16	8
29	14156	O-RING, M21.2 X 2.65	8
30	14594	GREASE ZERK - 7150	6
31	15820	BOLT, M8 X 1.25 X 110 FHCS	2
32	14126	BUSHING, FLANGED SLEEVE 12 X 16 X 12	4
33	14134	SPANNER, A ARM UPPER - 7150	2
34	14136-2	A ARM, UPPER - BLACK W/ZERK	2
35	14088	NUT, M8 X 1.25 LOCKING FLANGE ZN	2
36	15340-2	ASM, STRUT/SPINDLE LH - BLK	1
37	15341-2	ASM, STRUT/SPINDLE - BLK	1
38	14152	ASM, BRAKE CALIPER - RF - 7150	1
39	14143	ASM, BRAKE CALIPER - LF - 7150	1
40	14654	KIT, BRAKE PAD FRONT - 7150	2
41	15898	BOLT, M8 X 1.25 X 40 SHCS	2
42	14495	WASHER, M8 SPLIT LOCK	4
43	15897	BOLT, M8 X 1.25 X 25 SHCS	2

NOTE: parts denoted as left or right hand are from driver's point of view.

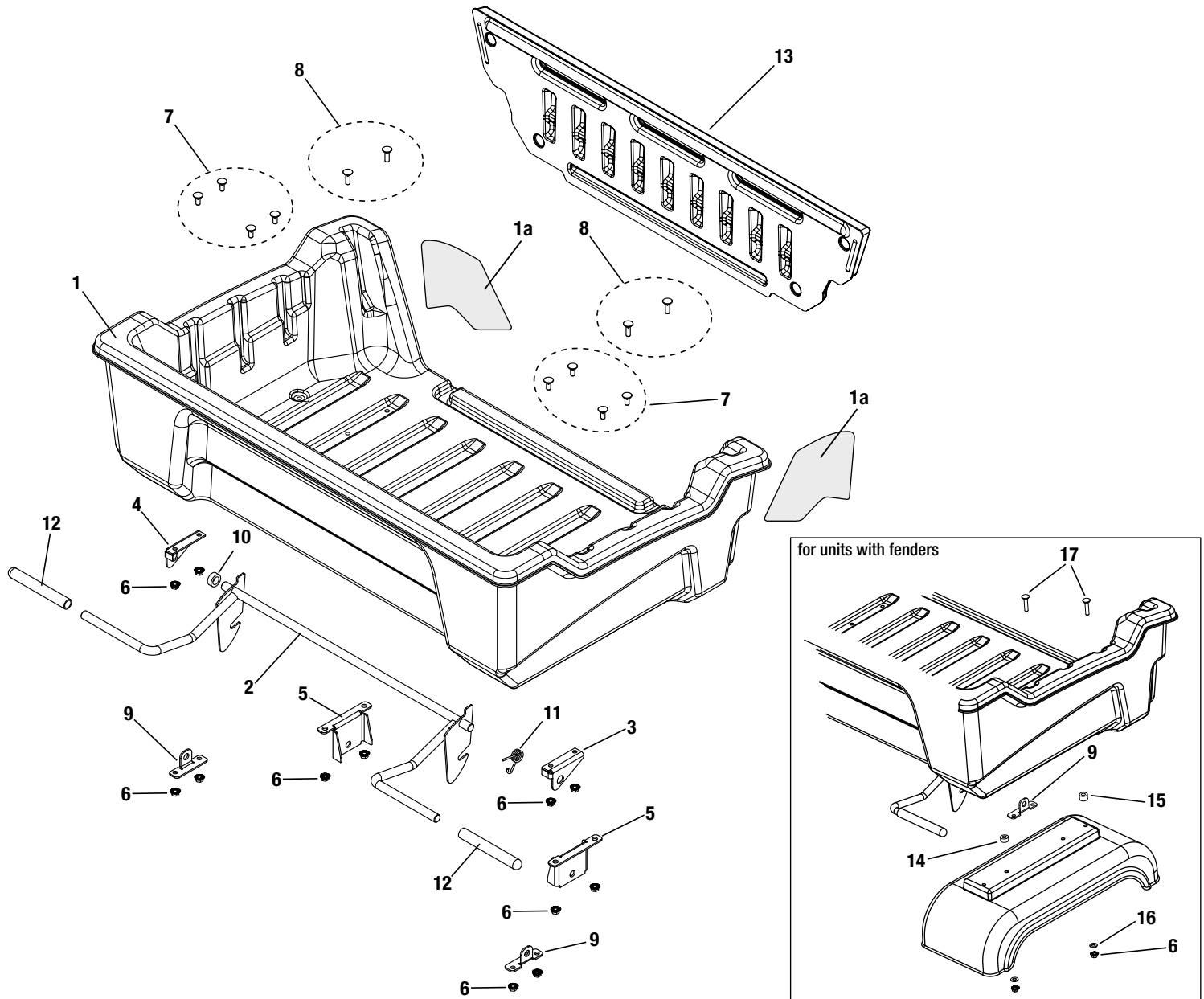

Ref#	Part#	Description	Qty
1	15575	BED, TWIN SHEET HDPE BLK	1
1a	15777	DECAL, REAR REFLECTIVE - RED (SET OF 2)	
2	15700-2	ASSEMBLY, BED LATCH HANDLE (BLACK)	1
3	15701-2	BRACKET, BED LATCH - LH (BLACK)	1
4	15702-2	BRACKET, BED LATCH - RH (BLACK)	1
5	15703-2	BRACKET, BED PIVOT (BLACK)	2
6	1263	NUT 5/16-18 HEX WF	14
7	15402	BOLT, 5/16-18 X 0.75 CARRIAGE G5	8
8	2-50152	BOLT, 5/16-18 X 1.0 CARRIAGE G5 ZN	4

Ref#	Part#	Description	Qty
9	15716-1E	BRACKET, TIE DOWN, BLK	2
10	15746	SPACER, NYLON 1" OD X 5/8" ID X .375" L	1
11	2-11801	SPRING, PEDAL	1
12	2-70241	RUBBER TUBE, BED LATCH COVER	2
13	15576	TAILGATE, TWIN SHEET HDPE BLK	1
14	15733	SPACER, NYLON 3/4" OD X 3/8" ID X 3/8" L	2
15	15734	SPACER, NYLON 3/4" OD X 3/8" ID X .5" L	2
16	9060	WASHER 5/16 TYPE A PLAIN SAE	2
17	10317	BOLT 5/16-18 X1.5 SQ NECK RD HEAD	4

NOTE: parts denoted as left or right hand are from driver's point of view.

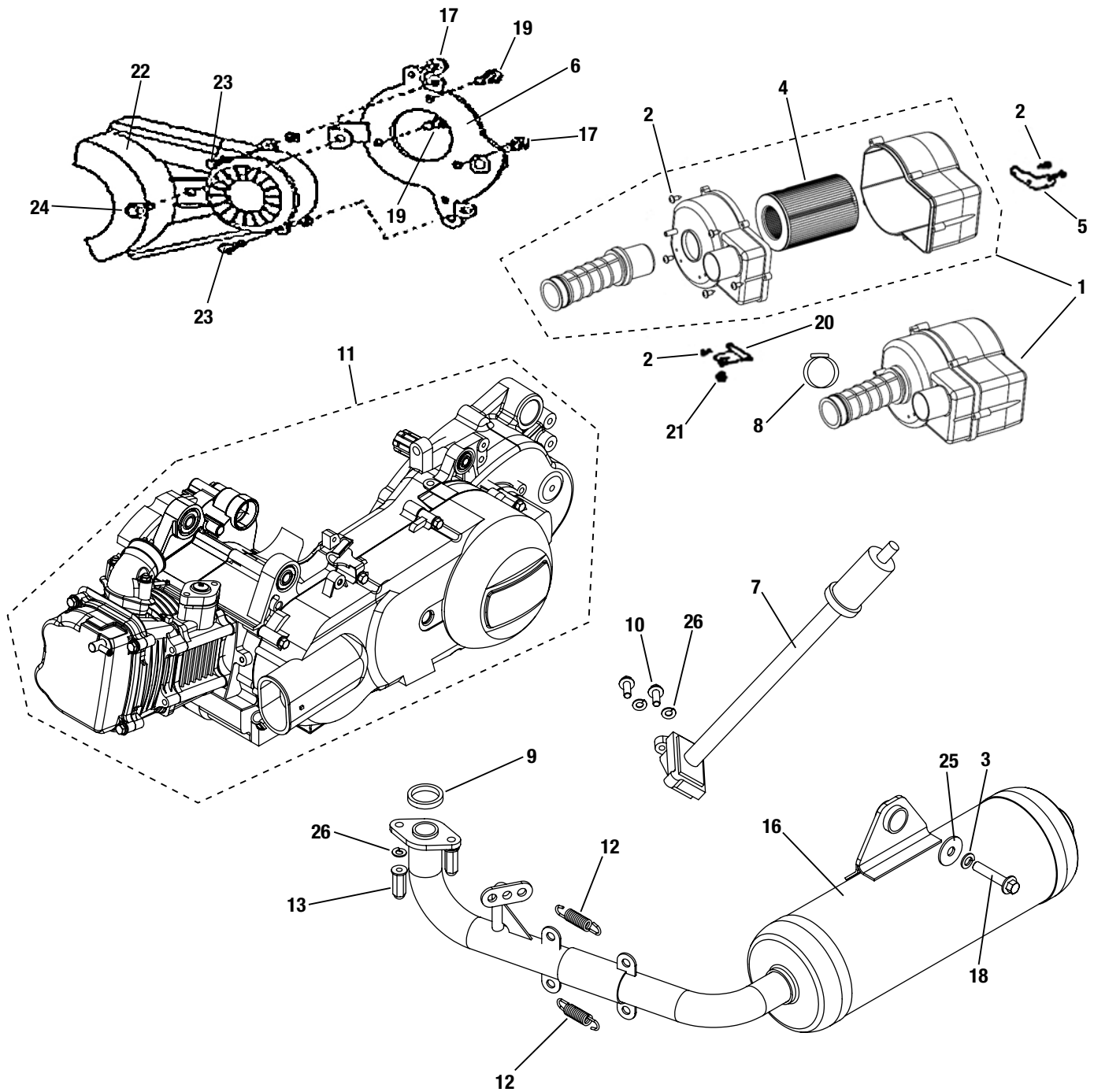

Ref#	Part#	Description	Qty
1	14192	ASM, AIR CLEANER - 150CC	1
2	14423	SCREW, M5 X 16 PHSM ZN	9
3	14495	WASHER, M8 SPLIT LOCK ZN	1
4	14194	FILTER, AIR - 150CC	1
5	14201	BRACKET, #2 AIR CLEANER MNT - 6150/7150	1
6	14480	BRACKET, REAR ENG MOUNT - 150CC	1
7	14762	AIR INJECTION ASM, MUFFLER - 6150/7150	1
8	14481	CLAMP, HOSE 45MM	2
9	14196	GASKET, EX PIPE - 150CC	1
10	14372	BOLT, M6 X 1.00 X 16 FHCS	2
11	14531	ASM, ENGINE - 7150	1
12	14482	SPRING, EXHAUST PIPE - 150CC	2

Ref#	Part#	Description	Qty
13	50050	NUT (HEX) CAP M6	2
16	14760	ASM, MUFFLER W/ AIR INJ MOUNT-6150/7150	1
17	14433	BOLT, M8 X 1.25 X 15 FHCS ZN	1
18	14439	BOLT, M8 X 1.25 X 40 FHCS ZN	1
19	14433	BOLT, M8 X 1.25 X 15 FHCS	3
20	14200	BRACKET, #1 AIR CLEANER MNT - 6150/7150	1
21	14445	BOLT, M8 X 1.25 X 10 FHCS ZN	1
22	14484	GUARD, CHAIN - 150CC	1
23	14430	BOLT, M6 X 1.00 X 30 FHCS	2
24	14436	BOLT, M8 X 1.25 X 30 FHCS	1
25	14497	WASHER, M8 X 27 X 2 FLAT ZN	1
26	14238	WASHER, M6 SPLIT LOCK DAC	4

NOTE: parts denoted as left or right hand are from driver's point of view.

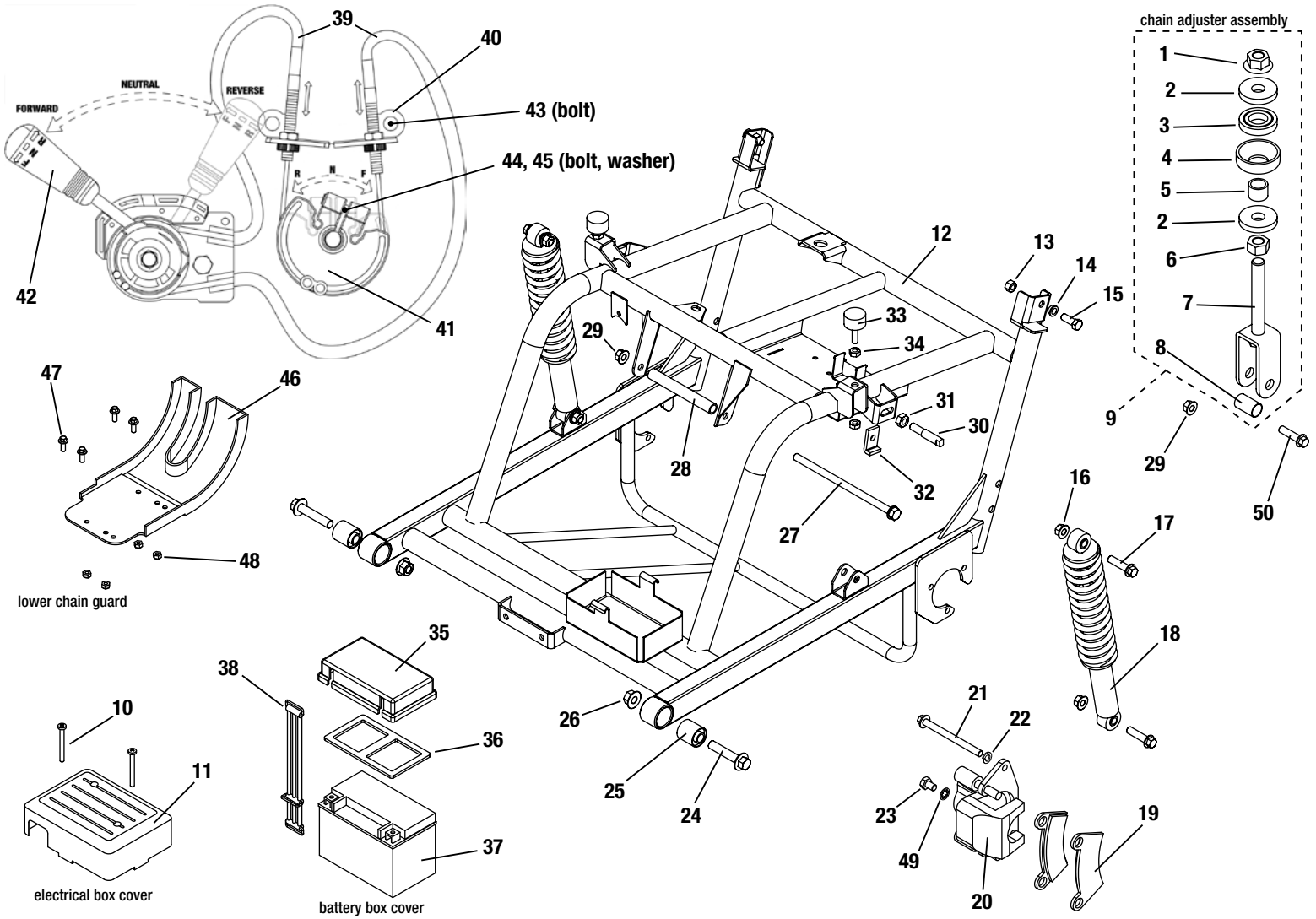

Ref#	Part#	Description	Qty
1	15828	NUT, M12 X 1.75 FLANGE TOP LOCK	1
2	14710	WASHER - CHAIN ADJUSTER	2
3	14467	BUSHING, ENGINE ADJ ISOLATOR	1
4	14468	SPACER, ENGINE ADJ CUP	1
5	14469	SPACER, ENGINE ADJ ALIGNMENT	1
6	14595	NUT, M12 X 1.75 HEX	1
7	15669	LINK, CHAIN TENSIONING	1
8	14471	SPACER, ENGINE MOUNTING LINK	1
9	15654	ASSEMBLY, CHAIN TENSIONING	1
10	14431	BOLT, M6 X 1.00 X 60 PHMS DAC	2
11	15323	COVER, ELECTRICAL BOX - BOX NO STOP SWIT	1
12	15718-2	FRAME, SWINGARM	1
13	15442	NUT, 3/8"-16 HEX CENTERLOCK	2
14	15717	BEARING, FLANGED SLEEVE	2
15	9099	BOLT 3/8-16 X 1.000 HHCS	2
16	15822	NUT, M10 X 1.5 FLANGE TOP LOCK	4
17	15824	BOLT, M10 X 1.5 X 40 FHCS	4
18	14808	SHOCK, 325MM - CHR/BLK	2
19	15077	KIT, BRAKE PAD REAR	1
20	15076	CALIPER, BRAKE WITH PADS - REAR	1
21	14615	BOLT, M8 X 1.25 X 95 FLANGE	1
22	14495	WASHER, M8 SPLIT LOCK	2
23	14432	BOLT, M8 X 1.25 X 12 HHCS	1
24	14452	BOLT, M12 X 1.25 X 60 FHCS	2
25	14191	BUSHING, SWINGARM ISOLATOR	2

Ref#	Part#	Description	Qty
26	14324	NUT, M12x1.25 LOCKING FLANGE DAC	2
27	14449	BOLT, M10 X 1.25 X 195 HHCS	1
28	14177	SPANNER, ENGINE MOUNT	1
29	14243	NUT, M10 X 1.25 LOCKING FLANGE	2
30	14906	PIN, LATCH	2
31	14907	NUT, LATCH ADJUST	2
32	14908	BRACKET, LATCH ADJUST	2
33	15088	SCREW, BED ADJUST W/ BUMPER	2
34	14610	NUT, M8 X 1.25	4
35	14186	COVER, BATTERY - 6150/7150	1
36	14188	GASKET, BATTERY CAP - 6150/7150	1
37	15653	BATTERY - YT7A-BS - 12V, 7 Ah	1
38	14187	STRAP, BATTERY HOLD DOWN - 6150/7150	1
39	14456	CABLE, D/N/R SHIFT	2
40	14473	BRACKET, SHIFT CABLE	1
41	14750	DISC, SHIFT CONTROL, METAL	1
42	14749	ASM, TRANS SHIFT LEVER, METAL	1
43	14433	BOLT, M8 X 1.25 X 15 FHCS ZN	2
44	14426	BOLT, M6 X 1.00 X 14 FHCS	1
45	14238	WASHER, M6 SPLIT LOCK	1
46	14185	GUARD, LOWER CHAIN	1
47	14372	BOLT, M6 X 1.00 X 16 FHCS	4
48	14236	NUT, M6 X 1.00 NYLOC	4
49	14500	WASHER, M8 STAR	1
50	14446	BOLT, M10 X 1.25 X 45 FHCS	1

NOTE: parts denoted as left or right hand are from driver's point of view.

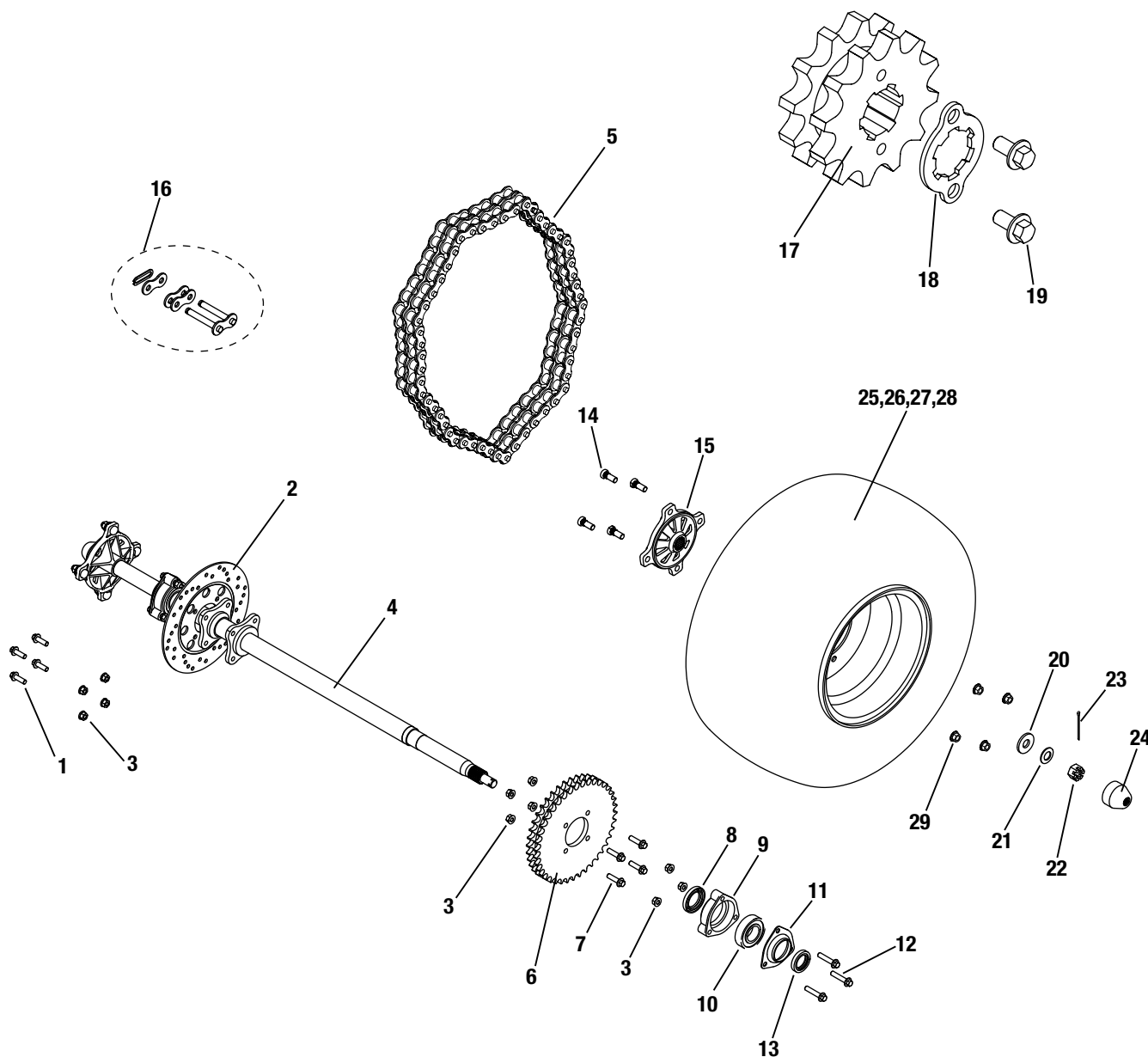

Ref#	Part#	Description	Qty
1	14435	BOLT, M8 X 1.25 X 22 FHCS ZN	4
2	14202	DISC, 8.75 REAR BRAKE - 6150/7150	1
3	14088	NUT, M8 X 1.25 LOCKING FLANGE ZN	16
4	14816	AXLE, TAPERED END - 200 SERIES	1
5	14831	CHAIN, DBL ROW 54 X 50P INCL ML	1
6	14819	SPROCKET, DBL ROW 40T - 200S	1
7	14436	BOLT, M8 X 1.25 X 25 FHCS ZN	4
8	14206	SEAL, M50 X 34 X 7 DUST	2
9	14207	HOUSING, AXLE BRG - 6150/7150	2
10	14208	BEARING - 6206	2
11	14209	FLANGE, BEARING - 6150/7150	2
12	14439	BOLT, M8 X 1.25 X 40 FHCS ZN	6
13	14210	SEAL, M42 X 30 X 7 DUST	2
14	14147	STUD, M10 X 1.25 X 31 WHEEL	8
15	14817	HUB, TAPERED 150CC - 4-165MM	2

Ref#	Part#	Description	Qty
16	14912	MASTER LINK, DR 50 CHAIN	1
17	14830	SPROCKET, DBL ROW 50P 12T - 200S	1
18	14218	KEEPER, SPROCKET - 6150/7150	1
19	14296	BOLT, M6 X 1.00 X 12 FHCS ZN	2
20	14248	SPACER, M16 X 16 X 4	2
21	15384	WASHER, BELLEVILLE, M16	2
22	14249	NUT, M16 X 2.00 CASTLE	2
23	15387	PIN, M3.2 X 32 COTTER	2
24	13930	CAP, RUBBER HUB NOSE	2
25	15672	ASM, 22X10-10 TIRE/WH RH - GBLK	1
26	15673	ASM, 22X10-10 TIRE/WH LH - GBLK	1
27	14814	TIRE, 22X10-10 - FAR EAST	1
28	15675	WHEEL, 10X8.5 - GBLK - 4-136	2
29	13979	NUT, M10 X 1.25 WF ZN	8

NOTE: parts denoted as left or right hand are from driver's point of view.

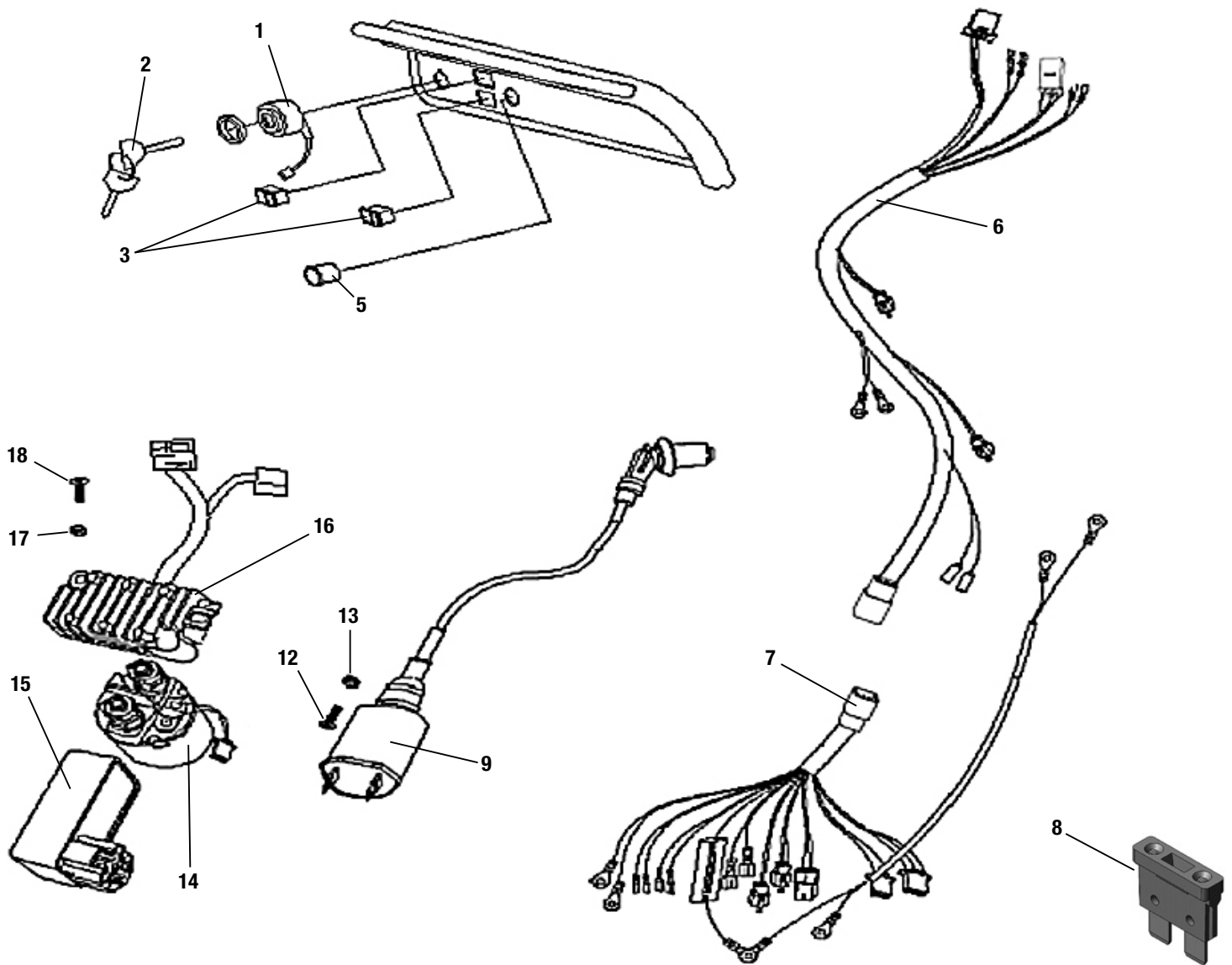

Ref#	Part#	Description	Qty
1	14222	SWITCH, KEYED IGNITION W/KEY - 6150/7150	1
2	14588	KEY SET - 6150/7150	1
3	14220	SWITCH, HEADLIGHT - 7150	2
5	16046	OUTLET, ACCESSORY-12V DC POWER	1
6	15573	HARNESS, MAIN CHASSIS AS201	1
7	15574	HARNESS, SWINGARM AS201	1
8	11081	FUSE 10 AMP BLADE TYPE	2
9	14227	COIL, IGNITION W/CAP - 6150/7150	1

Ref#	Part#	Description	Qty
12	14425	BOLT, M5 X .75 X 25 PHMS ZN	1
13	14491	NUT, M5 X .75 NYLOC ZN	1
14	14225	RELAY, STARTER - 6150/7150	1
15	14226	CDI - 6150/7150	1
16	15085	REGULATOR, VOLTAGE - HO ALTERNATOR - 200	1
17	14236	NUT, M6 X 1.00 NYLOC FLANGE ZN	2
18	14428	SCREW, M6 X 1.00 X 20 PHMS DAC	2

NOTE: parts denoted as left or right hand are from driver's point of view.

HEADLIGHT REPLACEMENT BULBS AND ASSEMBLIES FOR ASW UTILITY VEHICLES

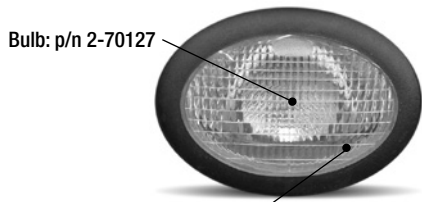

Bulb: p/n 2-70127

Assembly: p/n 2-70129
(5 1/4" oval)

Bulb: p/n 2-70127

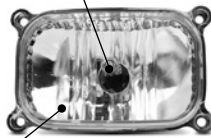

Assembly: p/n 2-70133
(4 3/8" rectangle)

Bulb: p/n 2-70127



Assembly: p/n 15648
(3 1/4" Round)

Bulb: Sealed housing
no bulb available



Assembly: p/n 14768
(4" round)

Light assembly: p/n 2-70158
(5" round)

Amber reflector: p/n 14784
(2 1/4" Round)



Bulb: p/n 2-70122

Plastic insert: p/n "Driver Side" 15944 (inner bezel)
15946 (outer bezel)

Plastic insert: p/n "Passenger Side" 15943 (inner bezel)
15945 (outer bezel)

Measurements are taken from left to right of the visible portion of the lens

Light assembly: p/n 2-70153 (driver side)
Light assembly: p/n 2-70154 (passenger side)

Bulb: p/n 15304

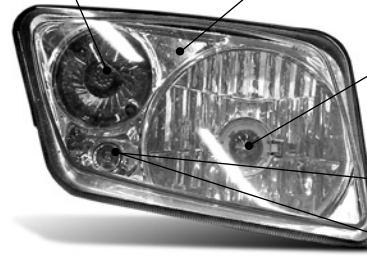

Bulb: p/n 2-70146

Twist-in Bulb:
Sylvania 1891 or equivalent



Depending on your year of manufacture,
this housing either has a "push-in" or "twist-in" bulb

Push-in Bulb:
Sylvania 2825 or equivalent



ORDERING PARTS

FAST & EASY!

- 1) Seek Part(s) from your models illustrated diagram, cross over REF# to PART#
- 2) Type PART# into sites [Search Box] at GoKartsRus.com TIP! - RIGHT CLICK LINK, SELECT OPEN IN NEW TAB
- 3) Add all needed parts to Shopping Cart | Complete "Checkout" | ✓ Done!

If a part does not come up in a Site Search, please [Contact Us](#) (include part# in email)

LOWEST PRICES!